

GM70C ENGINE METER USER MANUAL



Software Version

No.	Version	Date	Note
1	V1.0	2020-11-13	Original release.
2	V1.1	2022-08-22	Add CAN protocol, switch input.
3	V1.2	2023-08-01	Add multiple CAN protocols.
4	V1.3	2024-02-01	Add CAN protocols: Yunnei.



Chongqing Mebay Technology Co.,Ltd

Add: No6-2,Building 4, Gangan Rd, Jiangbei District, Chongqing.

Tel:+86-23-6869 3061



Fax:+86-23-6765 8207

Web:<http://www.mebay.cn>

<http://www.cqmb.cn>

E-mail:sales@mebay.cn

Symbol Description

Symbol	Description
 Note	Remind operators to operate correctly, otherwise it may cause the equipment not to work correctly.
 Be care	It is indicated that potential hazards can damage equipment without proper precautions.
 Warning	It is indicated if appropriate preventive measures are not taken, potentially dangerous situations may result in death, serious personal injury or significant property losses.

Warning

1. The installation of this equipment must be carried out by professionals.
2. When installing and operating the meter, please read the entire instruction manual first.
3. Any maintenance and commissioning of the equipment must be familiar with all the equipment.
4. Please comply with safety standards and precautions in advance, otherwise it may cause personal injury or damage to related equipment.
5. The engine must have an over speed protection device independent of the meter system to avoid casualties or other damage caused by engine out of control.
6. After the installation of the meter is completed, please verify that all protection functions are valid.

Be Care

1. Please keep the good connection of the power supply of the meter. Do not share the connection lines of the positive and negative electrodes of the battery with the floating charger.
2. During the operation of the engine, do not disconnect the battery, otherwise it may cause damage to the meter.

Catalogue

1. Summary	6
2. Main Features	6
3. Parameters Display	6
4. Protection	7
5. Parameters	7
6. Overall Dimension and Wiring Diagram	8
7. Installation instruction	11
8. Panel and display	12
9. Key Function Description	12
10. Warnings and Shutdown Alarms	13
11. Parameters setting	18
12. Fault finding	27



Note:

1. All rights reserved. No part of this duplication may be reproduced in any material form (including photocopying or storing in any medium by electronic means or others) without the written permission of the copyright holder.
2. MEBAY Technology reserves the rights to change the contents of this document without prior notice.

1. Summary

GM70C is specially designed for the parameter monitoring and fault monitoring of air compressor driven by diesel engine and gas engine. It is equipped with standard can communication port and built-in J1939 protocol. Relevant parameters can be read through CAN port of engine ECU.

4.3 inch colorful LCD screen display with brand new UI design is adapted in this meter that the relative failures can be displayed directly. All the parameters can be displayed by simulated indicators and words. Besides, LCD screen can display various faults in the same time that the gen set will be stopped once it can't work smoothly.

There are Chinese/English interface options, more language can be set according to user's request. All the parameters can be configured through the front face buttons or use programmable interface by RS485 or USB to adjust via PC.

2. Main Features

GM70C has CAN port, built-in J1939 protocol, alarm protection function and USB communication port, RS485 communication port, MODBUS communication protocol compatibility, and air compressor related parameter measurement, which is dedicated for diesel driven air compressor.

- ◆ 32bit high performance single chip microcomputer.
- ◆ 4.3inch TFT colorful big screen LCD, Available in 3 languages, user's language set if necessary.
- ◆ Indicator and number display through UI surface.
- ◆ Acrylic material is adapted to protect the screen.
- ◆ Silicone panels;
- ◆ USB Port: parameters can be set even without power through USB port to monitor in real time.
- ◆ With RS485 communication port, can achieve "Three Remote" functions via MODBUS protocol.
- ◆ Standard CAN communication port, built-in J1939 protocol.
- ◆ Various kinds of parameters display.
- ◆ Input/output function, status can be shown directly.
- ◆ More categories of surface setting.
- ◆ Protection countdown function;
- ◆ Real time clock inside ;which can set the maintenance time or date.
- ◆ The black box function can save the relevant parameters of the unit when the fault alarm occurs in real time, and it is convenient to find the cause of the fault.
- ◆ Totally 3 relay's output, among which 3 relay output can be self-configurable, each relay can be set with multiple functions, besides, there are 2 groups as non-contact terminals.
- ◆ With 4 switches input, can be set with multiple functions.
- ◆ 1 sensor simulation input connectors.
- ◆ Sensor can be self-defined by front face button or PC software.
- ◆ Standard water-proof rubber gasket. The waterproof can reach IP65.
- ◆ Module design: All the connections are adapted with European connectors so that installation, connection, repair and replacement can be more easily.
- ◆ With engine limited time use function.

3. Parameters Display

- ◆ engine RPM
- ◆ engine oil pressure
- ◆ engine water temperature
- ◆ engine oil temperature

- ◆ engine fuel level
- ◆ engine battery voltage
- ◆ ECU related parameters
- ◆ 4 switches input status display
- ◆ Output status display of 3 relays
- ◆ Cumulative number of startups
- ◆ Total number of alarms
- ◆ Total Crank times
- ◆ Current running time
- ◆ Total running time
- ◆ Maintenance notice

4. Protection

- ◆ Over speed
- ◆ Under speed
- ◆ Low oil pressure
- ◆ High water temperature
- ◆ High oil temperature
- ◆ Low oil level
- ◆ Low water level alarm
- ◆ External instant alarm
- ◆ Low coolant level switch warning
- ◆ Sensor Open
- ◆ Maintenance expire
- ◆ ECU alarm failure
- ◆ ECU communication Failure
- ◆ External shutdown alarm

5. Parameters

Options	Parameters
Working voltage	DC8V----36V Continuous
Power consumption	Standby:24V:MAX 1W
	Working:24V:MAX 3W
MAX Accumulating Time	99999.9Hours (Min Store time:6min)
AUX. OUTPUT 1	Max 5Amp DC+VE Supply voltage
AUX. OUTPUT 2	250V/5 AMP Non-contact normally Open/Closed output
AUX. OUTPUT 3	
Switch value input	Available if connecting with Battery -
Working condition	-30-70℃
Storage condition	-40-85℃
Protection Level	IP65:when waterproof rubber gasket is added between meter and its panel
Insulation strength	Apply AC2.2kV voltage between high voltage terminal and low voltage terminal; The leakage current is not more than 3mA within 1min.
Overall dimension	175mm*128mm*39mm
Panel cutout	152mm*112mm
Weight	0.5Kg

6. Overall Dimension and Wiring Diagram

◆ Overall Dimension:

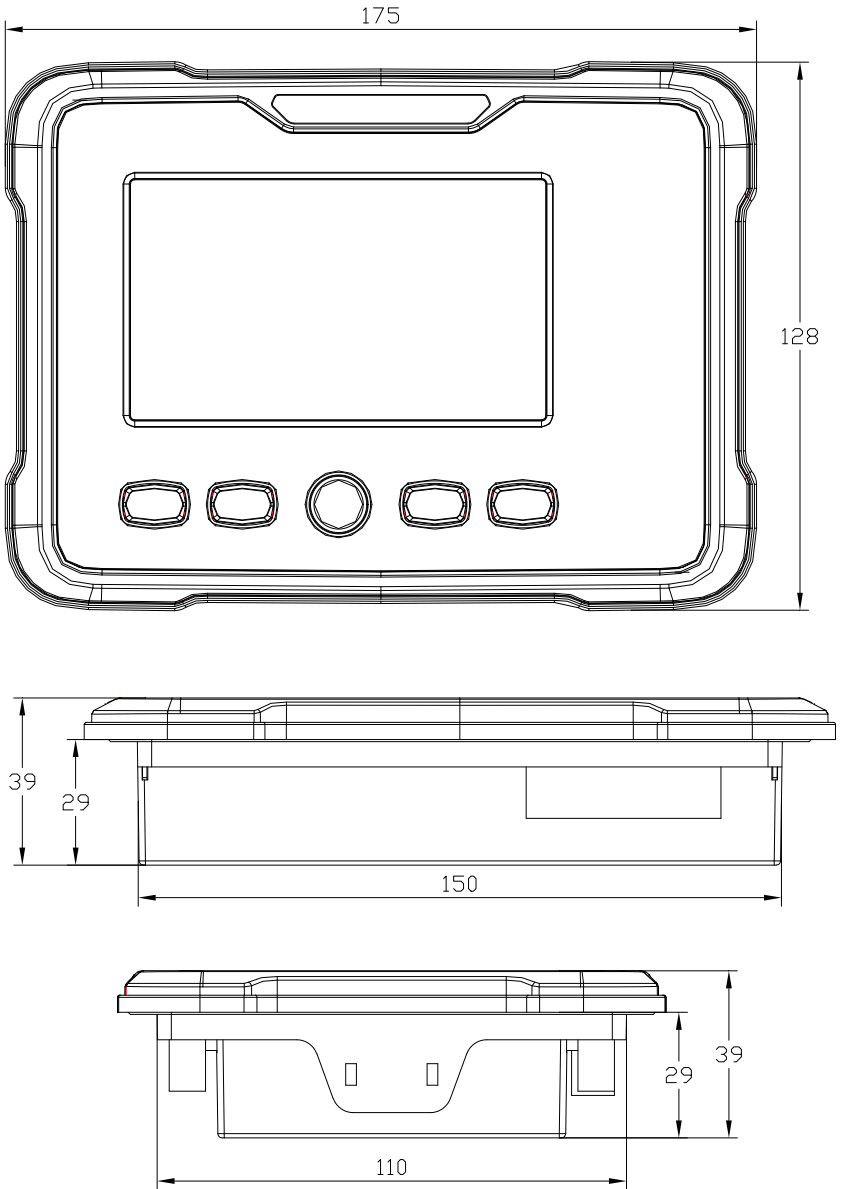

◆ Descriptions of terminal connection

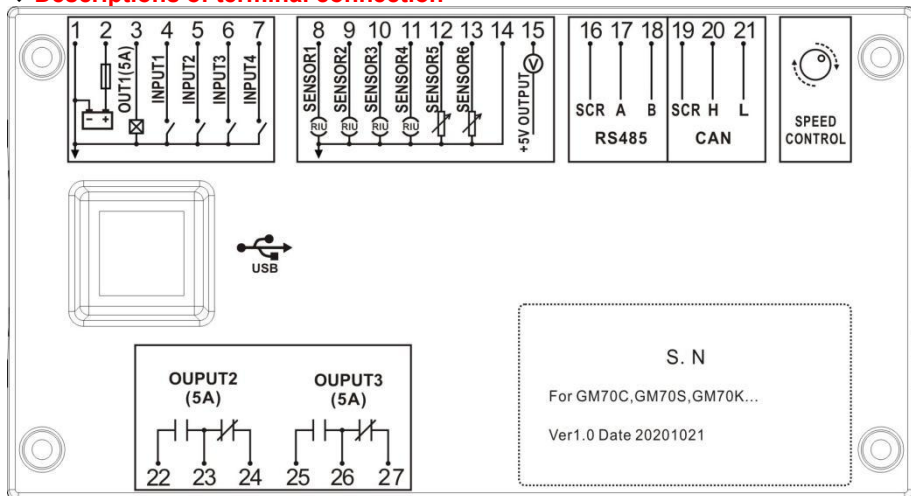

No.	Function	Description	Cable cross sectional area	
1	Battery Negative Input B-	meter power supply input B-.	1.5mm ²	
2	Battery Negative Input B+	meter power supply input B+.	1.5mm ²	
3	Aux. Output 1	Active output, Max 5Amp.	1.5mm ²	
4	Aux. Input 1	The grounding is valid according to the function selection switch input.	1.0mm ²	
5	Aux. Input 2		1.0mm ²	
6	Aux. Input 3		1.0mm ²	
7	Aux. Input 4		1.0mm ²	
8	Reserve	Resistive sensor;	1.0mm ²	
9	Reserve		1.0mm ²	
10	Reserve		1.0mm ²	
11	Reserve		1.0mm ²	
12	Reserve		1.0mm ²	
13	Fuel level sensor input		1.0mm ²	
14	Common GND	Connect the battery negative or outer casing.	1.5mm ²	
15	Reserve	5V power output, max 50mA	1.0mm ²	
16	RS485_SCR	A 120 Ω shielded wire and good grounding are recommended.	1.0mm ²	
17	RS485_A		1.0mm ²	
18	RS485_B		1.0mm ²	
19	CAN_SCR	Impedance-120Ω shielding wire is recommended, its single-end connect with ground.	1.0mm ²	
20	CAN_H		1.0mm ²	
21	CAN_L		1.0mm ²	
22	Aux. Output 2	Normally Open	Non-contact normally opened/closed output	1.5mm ²
23	COM		Max 250V/5Amp.	1.5mm ²

24		Normally Close		1.5mm2
25	Aux. Output 3	Normally Open	Non-contact normally opened/closed output Max 250V/5Amp.	1.5mm2
26		COM		1.5mm2
27		Normally Close		1.5mm2
SPC Rotary Encoder		5-position terminal is connected to the rotary encoder control board.		
USB-B				

◆ **GM70C Typical Wiring Diagram**

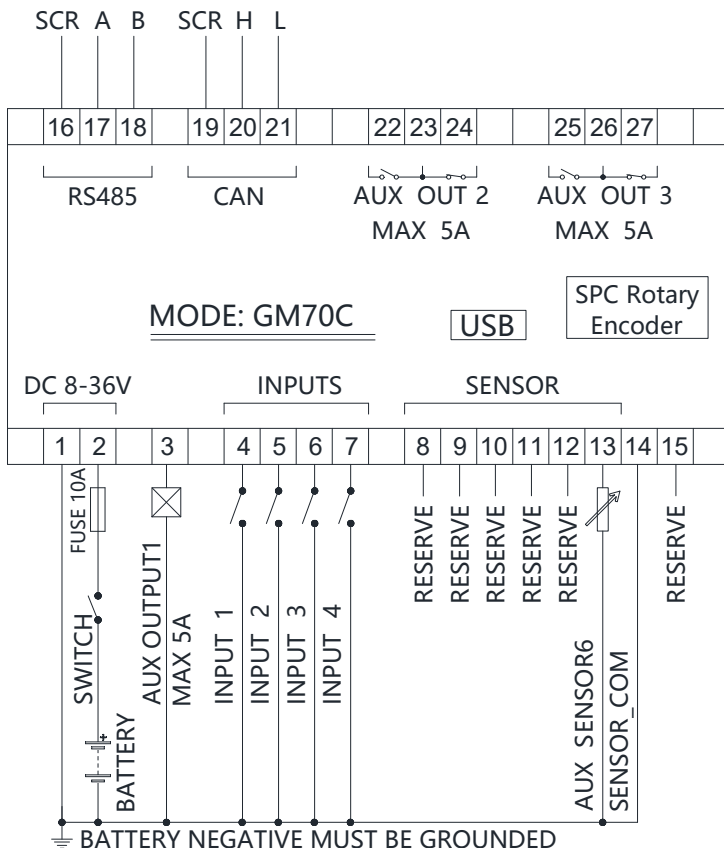

REMARK:

- 1.No. 14 common sensor lines must be securely attached to the vicinity of the sensor body.
- 2.To ensure reliable operation of the module and the measuring accuracy, power lines as much as possible and do not share power cable crude and other devices.



Note: Please don't move battery during running status or it may cause the meter broken!

7. Installation instruction

- ◆ The meter is fixed by two special fixing members and screws, and the screws of the metal fasteners cannot be too tight.
- ◆ Panel Cutout: W152mm*H112mm.

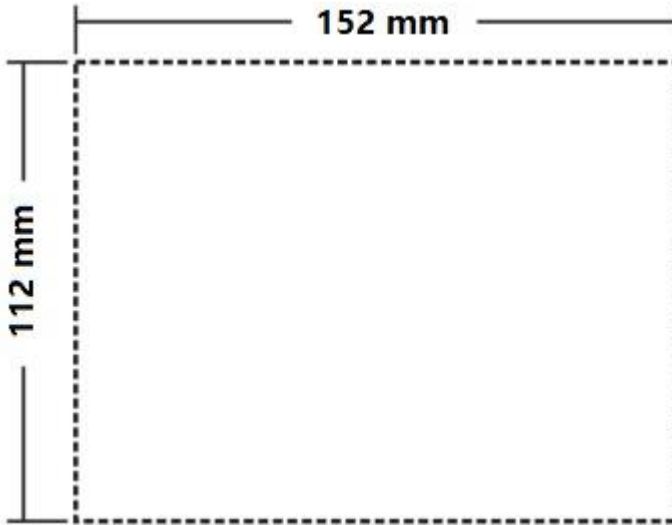

Note: If the meter is installed directly in the gen set shell or other fluctuated equipment, the rubber pad must be installed.

◆ Battery Voltage Input

GM70C meter is suitable for 8-36V DC battery voltage. Battery negative must be reliably connected to the enclosure of the engine. The meter power supply B+ and B- must be connected to battery positive and negative, and the wire size must not be less than 1.5mm².



NOTE:

In case of floating charger connect charger output to battery positive and negative directly, then, connect battery positive and negative poles to meter positive and negative power supply.

◆ Output and relay expansion



Note: All outputs of the meter are relay contacts. The maximum current capacity is described in the "Parameters" in this manual. Please use it in the relay current capacity. If an extended relay is needed, add a continuous current diode (when the extended relay coil is DC) or a resistance-capacitance loop (when the extended relay coil is AC) to both ends of the coil to prevent interference with the meter or other equipment.

◆ Withstanding voltage test



If withstanding voltage test is conducted after the meter has already been installed onto the control panel, please unplug all meter terminal connections in order to prevent high voltage from damaging it.

8. Panel and display











9. Key Function Description

KEYS	NAME	Main Function
	Setting	<ul style="list-style-type: none"> ◆ Press “PROG” for 3 sec to enter the setting menu; ◆ The meter cyclically switches working modes: meter mode, constant speed mode and variable speed control mode; ◆ Under edition mode, Press “PROG” for 3 sec to save and exit setting menu;
	Left	<ul style="list-style-type: none"> ◆ Under display mode, pressing this key to turn left page. ◆ Under edition mode, Press this key to return to the previous menu; ◆ Exit the setting mode, press this key to save and exit
	Right	<ul style="list-style-type: none"> ◆ Under display mode, pressing this key to turn right page. ◆ Under edition mode, pressing this key to move the digit.
	Up	<ul style="list-style-type: none"> ◆ Under constant speed mode, switch to rated operating speed. ◆ Under variable speed control mode, increase speed value. ◆ Under edition mode, pressing this key to move the digit or increase the numbers.
	Down	<ul style="list-style-type: none"> ◆ Under constant speed mode, switch to rated idle speed; ◆ Under variable speed control mode, decrease speed value; ◆ Under edition mode, pressing this key to move the digit or decrease the numbers.

◆ Alarm records checking

GM70C meter can save 50 group of alarm records which contains the alarm record data includes detailed data such as alarm time, engine parameters, input and output status.etc.

How to check the alarm records:

- 1) Enter alarm record page: under stop mode, Press  for 3 sec to enter the setting menu.
- 2) select into alarm records page;
- 3) Press  to turn upper digit and press  to turn lower digit in order to choose the record you need. Press  or  to confirm the record and come into history records checking page.
- 4) Press  to turn lower records under records checking page. Press  to turn upper records and press  to revert back to alarm history records page.
- 5) Exit from records page: In the history records page and checking page, press  to exit.

◆ This meter has three modes

1) meter mode:

Display engine related parameters through CAN port;

2) Constant speed mode:

Display the relevant parameters of the engine through the CAN port, the meter can control the engine to work at a fixed speed, and the idle speed and high speed of the engine can be switched through the panel buttons and external switches;

3) variable speed control mode:

The relevant parameters of the engine are displayed through the CAN port, and the meter can control the engine speed. The engine can be adjusted to work at a specified speed through the panel buttons and the external knob to realize the speed control function;

◆ Notices in Starting Process

 Note : Within the safety delay, only respond to immediately to external shutdown and over speed, other sensors and other alarms will not respond;

10. Warnings and Shutdown Alarms

 All warning and fault alarm functions need to turn on the meter alarm function, otherwise the alarm is invalid.

◆ Warnings

 Notes: Warning is a non-serious failure state, which will not harm the unit system for the time being. It only reminds operators to pay attention to the situation that does not meet the requirements and solve it in time to ensure the continuous operation of the system. When the warning occurs, the unit does not stop. Once the fault is removed, the warning is automatically canceled.

Over Speed Warning

When the meter detects that the engine speed is higher than "**Over speed warning**", Then start warning delay and the duration (over speed warning delay) have not returned to normal, the warning of over speed is reported. "**WARNING**" lights will light up, engine will not stop, displays "**Over speed**" on the current fault screen.

Under Speed Warning

When the meter detects that the engine speed is lower than "**Under speed warning**", Then start warning delay and the duration (under speed warning delay) have not returned to normal, the warning of under speed is reported. "**WARNING**" lights will light up, engine will not stop, displays "**Under speed**" on the current fault screen.

Low Oil Pressure Sensor Warning

When the meter detects that the Oil Pressure value is lower than the "**Low Oil Pressure warning**", Then start warning delay and the duration (low oil pressure alarm delay) have not returned to normal, the warning of low oil pressure warning is reported. "**WARNING**" lights will light up, engine will not stop, displays "**Low OP warning**" on the current fault screen.

High Coolant temperature sensor warning

When the meter detects that the coolant temperature value is higher than the "**High coolant temperature warning**", Then start warning delay and the duration (high coolant temperature alarm delay) have not returned to normal, the warning of high coolant temperature warning is reported. "**WARNING**" lights will light up, engine will not stop, displays "**High WT warning**" on the current fault screen.

High oil temperature sensor warning

When the meter detects that the oil temperature value is higher than the "**High oil temperature warning**", Then start warning delay and the duration (high oil temperature sensor alarm delay) have not returned to normal, the warning of high oil temperature warning is reported. "**WARNING**" lights will light up, engine will not stop, displays "**High OT warning**" on the current fault screen.

Low fuel level sensor warning

When the meter detects that the fuel level value is lower than the "**Low fuel level warning**", Then start warning delay and the duration (low fuel level sensor alarm delay) have not returned to normal, the warning of Low fuel level warning is reported. "**WARNING**" lights will light up, engine will not stop, displays "**Low fuel level**" on the current fault screen.

Low fuel level switch warning

When the meter detects that the programmable input "**Low fuel level warning input**" switch is active, it starts warning delay and lasts for normal alarm delay. When the "**Low fuel level warning input**" switch is enabled, the engine low fuel level switch warning is reported. "**WARNING**" lights will light up, engine will not stop, displays "**Low Fuel L warn**" on the current fault screen.

Low water level switch warning

When the meter detects that the programmable input "**Low water level warning input**" switch is active, it starts warning delay and lasts for normal alarm delay. When the "**Low water level warning input**" switch is enabled, the engine low water level switch warning is reported. "**WARNING**" lights will light up, engine will not stop, displays "**Low water L warn**" on the current fault screen.

Low oil level switch warning

When the meter detects that the programmable input "**Low oil level warning input**" switch is active, it starts warning delay and lasts for normal alarm delay. When the "**Low oil level warning input**" switch is enabled, the engine low oil level switch warning is reported. "**WARNING**" lights will light up, engine will not stop, displays "**Low oil level**" on the current fault screen.

External instant warning

When the meter detects that the programmable input "**External instant warning input**" switch is active, it starts warning delay and lasts for normal alarm delay. When the "**External instant warning input**" switch is enabled, the warning is reported. "**WARNING**" lights will light up, engine will not stop, displays "**Instant warn**" on the current fault screen.

Oil / Filter expiration warning

When the meter parameter "**Oil / Filter expiration**" is set to "**warning**", when the oil / filter to maintenance is detected as "0" or oil / filter maintenance date less than current date, then start warning delay and the duration (normal alarm delay), the warning of maintenance expiration is reported. "**WARNING**" lights on, without stopping the engine, and displays "**Oil / Filter expired**" on the LCD screen.

Air filter expiration warning

When the meter parameter "**Air filter expiration**" is set to "**warning**", when the air filter to maintenance is detected as "0" or air filter maintenance date less than current date, then start warning delay and the duration (normal alarm delay), the warning of maintenance expiration is reported. "**WARNING**" lights on, without stopping the engine, and displays "**Air filter expired**" on the LCD screen.

Fuel filter expiration warning

When the meter parameter "**Fuel filter expiration**" is set to "**warning**", when the fuel filter to maintenance is detected as "0" or fuel filter maintenance date less than current date, then start warning delay and the duration (normal alarm delay), the warning of maintenance expiration is reported. "**WARNING**" lights on, without stopping the engine, and displays "**Fuel filter expired**" on the LCD screen.

ECU warning

When the meter detects the warning information of ECU, Then start warning delay and the duration (normal alarm delay) have not returned to normal, the warning of ECU warning is reported. "**WARNING**" lights will light up, engine will not stop, displays "**ECU warning**" on the current fault screen.

ECU Communication Failure Warning

When the meter parameter "**CAN failure**" is set to "**warning**", and meter does not receive any message sent by ECU. It started to delay and lasted for some time (normal alarm delay), but still did not receive the message from ECU, the warning of ECU faults warning is reported. "**WARNING**" lights will light up, engine will not stop, displays "**ECU comms. fail**" on the current fault screen.

Over battery voltage warning

When the meter detects that the battery voltage is over than the "**Over battery**

voltage warning", Then start warning delay and the duration (over battery voltage alarm delay) have not returned to normal, the warning of over battery voltage warning is reported. **"WARNING"** lights will light up, engine will not stop, displays **"Over BATT volt"** on the current fault screen.

Under battery voltage warning

When the meter detects that the battery voltage is lower than the **"Under battery voltage warning"**, Then start warning delay and the duration (under battery voltage alarm delay) have not returned to normal, the warning of under battery voltage warning is reported. **"WARNING"** lights will light up, engine will not stop, displays **"Under BATT volt"** on the current fault screen.

◆ Shutdown Alarms



Warning: Shutdown failure will immediately lock the system and stop the operation of the unit. Only after the failure is eliminated and the power is reset, the meter can be operated.



Notes:When the shutdown alarm failure occurs, the **"ALARM"** lights will light up and the unit automatically stops.(Turn on the meter alarm function, otherwise the alarm is invalid, and configure the alarm output time at the same time)

Over Speed Alarm

When the meter detects that the engine speed is higher than **"Over speed alarm"**, Then start alarm delay and the duration (over speed alarm delay), the alarm of over speed is reported. **"ALARM"** lights will light up, engine stops running, and displays **"Over speed "** on the current fault screen.

Under Speed Alarm

When the meter detects that the engine speed is under than **"Under speed alarm"**, Then start alarm delay and the duration (under speed alarm delay) the alarm of under speed is reported. **"ALARM"** lights will light up, engine stops running, and displays **"Under speed "** on the current fault screen.

Low Oil Pressure Sensor Alarm

When the meter detects that the engine Oil Pressure is lower than **"Low oil pressure alarm"**, Then start alarm delay and the duration (normal alarm delay) have not returned to normal, the alarm of low oil pressure is reported. **"ALARM"** lights will light up, engine stops running, and displays **"Low OP alarm"** on the current fault screen.

High coolant temperature sensor alarm

When the meter detects that the coolant temperature value is higher than the **"High coolant temperature alarm"**, Then start alarm delay and the duration (high coolant temperature sensor alarm delay) have not returned to normal, the alarm of high coolant temperature alarm is reported. **"ALARM"** lights will light up, engine stops running, and displays **"High WT alarm"** on the current fault screen.

High oil temperature sensor alarm

When the meter detects that the oil temperature value is higher than the **"High oil temperature alarm"**, Then start alarm delay and the duration (high oil temperature

sensor alarm delay) have not returned to normal, the alarm of high oil temperature alarm is reported. **"ALARM"** lights will light up, engine stops running, and displays **"High OT alarm"** on the current fault screen.

Low fuel level sensor alarm

When the meter detects that the fuel level value is lower than the **"Low fuel level alarm"**, Then start alarm delay and the duration (low fuel level sensor alarm delay) have not returned to normal, the alarm of Low fuel level alarm is reported. **"ALARM"** lights will light up, engine stops running, and displays **"Low fuel level alarm"** on the current fault screen.

Low fuel level switch alarm

When the meter detects that the programmable input **"Low fuel level alarm input"** switch is active, it starts alarm delay and lasts for normal alarm delay. when the **"Low fuel level alarm input"** switch is enabled, the engine low fuel level switch alarm is reported. **"ALARM"** lights will light up, engine stops running, and displays **"Low fuel level-D"** on the current fault screen.

Low water level switch alarm

When the meter detects that the programmable input **"Low water level alarm input"** switch is active, it starts alarm delay and lasts for normal alarm delay. when the **"Low water level alarm input"** switch is enabled, the engine low water level switch alarm is reported. **"ALARM"** lights will light up, engine stops running, and displays **"Low water level"** on the current fault screen.

Low oil level switch alarm

When the meter detects that the programmable input **"Low oil level alarm input"** switch is active, it starts alarm delay and lasts for normal alarm delay. When the **"Low oil level alarm input"** switch is enabled, the engine low oil level switch alarm is reported. **"ALARM"** lights will light up, engine stops running, and displays **"Low oil level-D"** on the current fault screen.

External instant alarm

When the meter detects that the **"External instant alarm input"** switch of the programmable input port is valid, the external instant started shutdown alarm delay is delayed for a period of time **"Normal alarm delay"** programmable input port **"External instant alarm input"** switch When it is valid, it will alarm, the public alarm light **"ALARM"** lights will light up, engine stops running, and display **"Instant alarm switch"** on the current fault screen.

OWS blocked alarm

When the meter detects that the **"OWS blocked alarm input"** switch of the programmable input port is valid, the OWS blocked started shutdown alarm delay is delayed for a period of time **"Normal alarm delay"** programmable input port **"OWS blocked alarm input"** switch when it is valid, it will alarm, the public alarm light **"ALARM"** lights will light up, engine stops running, and display **"OWS blocked alarm"** on the current fault screen.

Air filter block alarm

When the meter detects that the **"Air filter block alarm input"** switch of the

programmable input port is valid, the air filter block started shutdown alarm delay is delayed for a period of time "**Normal alarm delay**" programmable input port "**Air filter block alarm input**" switch when it is valid, it will alarm, the public alarm light "**ALARM**" lights will light up, engine stops running, and display "**Air filter block**" on the current fault screen.

Clogged oil filter alarm

When the meter detects that the "**Clogged oil filter alarm input**" switch of the programmable input port is valid, the clogged oil filter started shutdown alarm delay is delayed for a period of time "**Normal alarm delay**" programmable input port "**Clogged oil filter alarm input**" switch when it is valid, it will alarm, the public alarm light "**ALARM**" lights will light up, engine stops running, and display "**Clogg oil filter**" on the current fault screen.

Oil / Filter expiration alarm

When the meter parameter "**Oil / Filter expired**" is set to "**alarm**", when the Oil / filter expired to maintenance is detected as "0" or Oil/Filter maintenance date less than current date, then start alarm delay and the duration (normal alarm delay), the alarm of maintenance expiration is reported. "**ALARM**" lights on, engine stops running, and displays "**Oil / Filter expired**" on the LCD screen.

Air filter expiration alarm

When the meter parameter "**Air filter expired**" is set to "**alarm**", when the air filter expired to maintenance is detected as "0" or air filter maintenance date less than current date, then start alarm delay and the duration (normal alarm delay), the alarm of maintenance expiration is reported. "**ALARM**" lights on, engine stops running, and displays "**Air filter expired**" on the LCD screen.

Fuel filter expiration alarm

When the meter parameter "**Fuel filter expired**" is set to "**alarm**", when the fuel filter expired to maintenance is detected as "0" or fuel filter maintenance date less than current date, then start alarm delay and the duration (normal alarm delay), the alarm of maintenance expiration is reported. "**ALARM**" lights on, engine stops running, and displays "**Fuel filter expired**" on the LCD screen.

ECU stop alarm

When the meter detects the alarm information of ECU, Then start alarm delay and the duration (normal alarm delay) have not returned to normal, the alarm of ECU faults alarm is reported. "**ALARM**" lights will light up, engine stops running, displays "**ECU stop**" on the current fault screen.

ECU communication failure alarm

When the meter parameter "**CAN failure**" is set to "**alarm**", and meter does not receive any message sent by ECU. It started to delay and lasted for some time (normal alarm delay) but still did not receive the message from ECU, the alarm of ECU faults alarm is reported. "**ALARM**" lights will light up, engine stops running, displays "**ECU comm. fail**" on the current fault screen.

11. Parameters setting

◆ Enter the edition page

Please set the parameters according to below steps:



- 1) In the stop mode, Press and hold the **PROG** button for more than 3 seconds, to enter the setting menu interface;
- 2) Select the detailed parameter settings of the meter and press the **PROG** or **▶** key to enter the password interface;
- 3) The default factory password of the meter is "07623";
- 4) Press **▲** and add number 1, press **▼** to reduce number 1, press **▶** to turn the digit into right, press **◀** to save and return to the previous menu, press **PROG** once done. Then system comes into menu after confirmation of password setting. The screen will display error if password is wrong. The correct password should be put after pressing any button.
- 5) In the menu interface, press **▲** to move the cursor up, press **▼** to move the cursor down, press **▶** to enter the parameter viewing interface that needs to be set, and press **◀** to return to the previous menu;
- 6) In the parameter view interface, press **▲** to move the parameter up, press **▼** to move the parameter down, and press **▶** to enter the modification interface;
- 7) Press **▲** to add number 1, press **▼** to reduce number 1, press **▶** to turn the digit into right, press **PROG** once done. If the parameters setting is in the valid setting range, then it can be saved, if not, it can't be saved.
- 8) Press the **PROG** key for more than 3 seconds without releasing it or keep pressing **◀** to exit the parameter setting interface and save the parameter setting.
- 9) At any position in the setting mode, press **◀** to return to the previous menu, and return to the menu level by level.

⚠ Note: If you exit the parameter setting interface in any way after setting the parameters, the parameters will be saved!

◆ Parameter list.

1) Basic settings

No	Parameter	Range(default)	Notes
1	Language	0: English 1: 简体中文 2: 繁体中文	Language option.
2	meter working mode	0: Meter 1: Constant 2: Speed C. 3: Constant/ Speed C. 4: Meter/Constant/Speed C.	meter working mode.
3	Rated idle speed value	500-4500RPM (900RPM)	Set the engine speed when idling.
4	Rated operating	500-4500RPM	Choose the meter range and calculate the alarm

	speed	(1500RPM)	value.
5	Maximum speed value	500-4500RPM (2500RPM)	Set the maximum speed for engine speed control.
6	Speed increase or decrease step	1-200RPM (50RPM)	The step length of the speed increase when the  key is pressed once. The step size of the speed decrease when the  key is pressed once.
7	Clutch disconnect speed	0-4500RPM (900RPM)	When the speed value is higher than this value, the clutch relay outputs.
8	Clutch speed	0-4500RPM (950RPM)	When the speed value is less than this value, the clutch relay is disconnected.
9	Rated BATT voltage	8.0-36.0V (24.0V)	Standard for detecting of over/under voltage of battery.
10	Crank dis on OP	0-400kpa (200kpa)	When the engine oil pressure is over the condition value, then system regards it as crank success, motor escaped.
11	Crank dis on RPM	200-1000RPM (600RPM)	Rated RPM multiplying by this value is regarded as crank success condition. When the RPM is over the condition value, then system regards it as crank success, motor escaped.
12	Safety delay	1.0-60.0s (10.0s)	Delay time for external shutdown alarm and overspeed alarm.
13	Emergency delay	0-10.0s (1.5s)	Emergency and over frequency alarm delay.
14	Normal fault delay	2.0-20.0s (5.0s)	The alarm delay except for emergency stop and over frequency.
15	Alarm output time	0-120S (30S)	Set the alarm relay output action. 0S: The alarm relay does not output when alarming; 120S: The alarm relay always outputs when alarming.
16	Fuel level sensor type	0: Disable 1: Self-define resistance curve 2: 0—100Ω 3: 100—0Ω 4: 0—107Ω 5: 107—0Ω 6: 0—180Ω 7: 180—0Ω 8: 180—10Ω 9: 10—180Ω 10: 120—10Ω 11: 10—120Ω 12: 90—0Ω 13: 0—90Ω 14: 0—30Ω 15: 73—10Ω 16: 240—33Ω 17: 33—100Ω 18: 0—200Ω	If the sensor used by the user is not the commonly used type, it can be User-defined.

		19: 200—0Ω 20: 100—33Ω	
17	Fuel level open circuit action	0: Disable 1: Warn 2: Alarm and stop	Action if Fuel level sensor disconnected.
18	Temperature/pressure unit	0: °C/KPA 1: °C/BAR 2: °C/PSI 3: F/KPA 4: F/BAR 5: F/PSI	Sensor display unit.
19	Set password	00000-65535 (07623)	Change the password.

2) CAN communication

No	Parameter	Range(defaults)	Notes
1	CAN protocol type	0. J1939-C Speed Con. 1. GTSC1 2. BOSCH 3. YUCHAI-YCECU 4. WEICHAI-WISE15 5. YUCHAI-LMB 6. DEUTZ EMR2—2012 7. DEUTZ EMR3 8. Cummins-DGEC QSZ13 9. DEUTZ EMR4 10. DEUTZ EMR2—2001 11. GTSC1 TE 12. VOLVO—EMS 13. J1939—C Self-define 14. J1939—C DCEC 15. Cummins QSX15-CM570 16. Cummins-CM850-PCC13X 17. Perkins-1100 18. Volvo-EMS2 19. Volvo-EMS2b 20. Scania 21. mtu-ADEC 22. mtu-ADEC-SAM 23. CHANGCHAI-ECU15 24. MAN 25. YTO 26. NEWND ECU13 27. Cummins-CM2150 28. WP6-2 29. YK-121	CAN communication protocol selection. When the corresponding communication protocol is selected, the engine parameters such as speed, oil pressure, and water temperature displayed by the meter all come from ECU data. The speed control function can only be effective when the ECU opens the speed control authority.
2	ECU comm. fail	0: Disable 1: Warn 2: Alarm and stop	ECU communication failure alarm action.
3	ECU warning enable	0: Disable 1: Enable	ECU warnings enable.

4	ECU alarm function	0: Disable no SPN 1: Disable alarm SPN 2: Enable alarm SPN	When the ECU has an alarm failure, if set to 0, it will not respond to the alarm and stop without displaying the alarm code; set to 1 to not respond to the alarm and stop but display the alarm code normally; set to 2 to respond to the alarm and stop and display the alarm code.
5	ECU alarm code shielding	00000000	A total of 10 groups of alarm codes can be entered, and the meter will no longer respond and display the entered alarm codes.
6	ECU speed control address	00000000 — FFFFFFFF (0C000003)	For the TSC1 message ID address sent by the controller to the ECU, it is valid when the communication protocol is 12: VOLVO-EMS or 13: J1939-C is selected.
7	ECU speed control data	00 00 00 00 00 00 00 00— FF FF FF FF FF FF FF FF (01 xx xx 00 00 00 00 00)	For the message format of TSC1 speed control data sent by the controller to the ECU, it is valid when the communication protocol is 12: VOLVO-EMS or 13: J1939-C is selected.
	ECU speed sending interval	5-6000ms(10ms)	The interval time of TSC1 speed control data message sent by the controller to the ECU, it is valid when the communication protocol is 12: VOLVO-EMS or 13: J1939-C is selected.
8	CAN Baud Rate	0-250kbps 1-500kbps	Set the baud rate of CAN bus communication.

3) Engine alarm setting

No	Parameter	Range (default)	Notes
1	meter alarm function enable	0: Disable 1: Enable	When set to 0, low fuel level, switch input alarm indication and output are prohibited.
2	Over speed warning	0-200% (107%)	Rated RPM multiplying by this value is regarded as over speed warning value. When the RPM is higher than the warning value and comes into over speed delay but still higher, then over speed warns. if the value is set as 200, then the over speed alarm is disabled.
3	engine over speed alarm	0-200% (114%)	Rated RPM multiplying by this value is regarded as over speed alarm value. When the RPM is higher than the alarm value and comes into over speed delay but still higher (emergency faults delay), then over speed alarms. if the value is set as 200, then the over speed alarm is disabled.
4	Under speed warning	0-200% (0%)	Rated RPM multiplying by this value is regarded as under speed warning value. When the RPM is lower than the warning value and comes into under speed delay but still lower (normal warning delay), then under speed warns. if the value is set as 0, then the over speed alarm is disabled.
5	engine under	0-200%	Rated RPM multiplying by this value is regarded as

	speed alarm	(0%)	under speed alarm value. When the RPM is lower than the alarm value and comes into under speed delay but still lower (normal faults delay), then under speed alarms. if the value is set as 0, then the under speed alarm is disabled.
6	Low OP warning	0-999kpa (180kpa)	When the oil pressure is lower than the warning value and comes into low oil pressure delay but still lower (normal faults delay), then low oil pressure warning. if the value is set as 0, then the under speed warning is disabled.
7	Low OP alarm	0-999kpa (103kpa)	When the oil pressure is lower than the alarm value and comes into low oil pressure delay but still lower (normal faults delay), then low oil pressure alarms. if the value is set as 0, then the under speed alarm is disabled.
8	High WT warning	20-200°C (95 °C)	When the water temperature is higher than the warning value and comes into high temperature delay but still higher (normal faults delay), then high temperature warning. if the value is set as 200, then the high temperature warning is disabled.
9	High WT alarm value	20-200°C (98 °C)	When the water temperature is higher than the alarm value and comes into high temperature delay but still higher (normal faults delay), then high temperature alarms. if the value is set as 200, then the high temperature alarm is disabled.
10	High OT warning	20-200°C (95 °C)	When the oil temperature value of the external oil temperature sensor is greater than this value, the high oil temperature warning delay starts and continues for a period of time (general failure delay) and is still not less than the high oil temperature warning value, then the high temperature oil warning is issued. When the oil temperature value is less than this value, the warning is released. When set to 200, high oil temperature warning is disabled.
11	High OT alarm value	20-200°C (100 °C)	When the oil temperature value of the external oil temperature sensor is greater than this value, the high oil temperature delay starts and continues for a period of time (general failure delay) but is still not less than this value, then the high oil temperature alarms and stops. If the oil temperature drops less than the “high oil temperature alarm value” in the “general failure delay”, it is considered that the engine fluctuates normally, and this value is only judged after the safety delay ends. When set to 200, the high oil temperature alarm is disabled.
12	Low fuel warning	0-100% (20%)	When the fuel level is lower than the value and comes into low fuel level warning delay but still lower (normal warning delay), then low fuel level warns. If it is higher than the value then warning clears. If the value is set as 0, then the low fuel level warning is disabled.

13	Low fuel level alarm	0-100% (0%)	When the fuel level is lower than the alarm value and comes into low fuel level delay but still lower (normal faults delay), then low fuel level alarms. if the value is set as 0, then the low fuel level alarm is disabled.
14	Over battery warning	0-200% (135%)	Rated battery voltage multiplying by this value is regarded as over battery voltage warning value. When the battery input is higher than the warning value and comes into over battery voltage delay but still higher (normal faults delay), then over battery voltage warns. if the value is set as 200, then the over battery voltage is disabled.
15	Low battery warning	0-200% (67%)	Rated battery voltage multiplying by this value is regarded as under battery voltage warn value. When the battery input is lower than the warning value and comes into under battery voltage delay but still lower (normal faults delay), then under battery voltage warns. if the value is set as 0, then the under battery voltage is disabled.

4)Input/Output setting

No	Parameters	Range(defaults)	Notes
1	AUX. OUTPUT 1 (Functional of PIN 3)	0-13 (1:Public warning)	0: Disable. 1: Public warning: when there is any warning output. 2: Public alarm: When the unit has any alarm, stop output. 3: Running: output under running, off once RPM is lower than cranking RPM. The crank success condition can be set. 4: Over speed alarm: The relay outputs when the meter generates over speed/over frequency alarm. 5: Over speed warning: The relay will output when the meter generates over speed/over frequency warning. 6: Low oil pressure: The relay will output when the meter generates a low oil pressure sensor/switch alarm. 7: High WT alarm: When the meter generates a high water temperature sensor/switch alarm, the relay outputs. 8: High OT alarm: When the meter generates a high oil temperature sensor/switch alarm, the relay outputs. 9: High speed con: No output at idling speed, output at high speed. 10: Clutch control: Output when the speed is higher than "Clutch Disconnect Speed", and disconnect when it is lower than "Clutch Combine Speed". 11: ECU warning: there is a warn signal from
2	AUX. OUTPUT 2 (Functional of PIN 22,23,24)	0-13 (2:Public alarm)	
3	AUX. OUTPUT 3 (Functional of PIN 25,26,27)	0-13 (9:High speed con)	

			<p>ECU. 12: ECU alarm:there is an alarm signal from ECU. 13: ECU Comms. Fail:Display meter cannot communicate with ECU.</p>
4	AUX. INPUT 1 (Functional of PIN 4)	0-14 (7: Instant warning)	<p>0: Disable 1: Low water L warn 2: Low water L alarm 3: Low Fuel L warn 4: Low Fuel L stop 5: Low oil L alarm 6: Low oil level 7: Instant warning 8: Stop alarm input 9: Speed up input: After the input is valid, the speed will increase once (the step size is the throttle resolution), which can be connected to the self-reset button. 10: Slowdown input: After the input is valid, the speed is reduced once (the step size is the throttle resolution), and the self-reset button can be connected. 11: Idle control: When it is connected to the ground, it enters idle speed, and when it is disconnected to the ground, it enters high speed.(Valid only in constant mode) 12: Oil filter clog. 13: OWS blocked. 14: Air filter clog. 15: Start input: when the switch signal is valid, send the ECU start message (only the VOLVO-EMS\J1939—C Self-define protocol is valid, and the self-reset switch is used at the same time) 16: Stop input: when the switch signal is valid, send the ECU start message (only the VOLVO-EMS\ J1939—C Self-define protocol is valid, and the self-reset switch is used at the same time) (the valid state of input can be set separately, the closed state is grounded, and the open state is suspended.)</p>
5	AUX. INPUT 1 Valid type	0-Normal close 1-Normal open	
6	AUX. INPUT 2 (Functional of PIN 5)	0-14 (8: Stop alarm input)	
7	AUX. INPUT 2 Valid type	0-Normal close 1-Normal open	
8	AUX. INPUT 3 (Functional of PIN 6)	0-14 (0:Disable)	
9	AUX. INPUT 3 Valid type	0-Normal close 1-Normal open	
10	AUX. INPUT 4 (Functional of PIN 7)	0-14 (0:Disable)	
11	AUX.INPUT 4 effective type	0-Normal close 1-Normal open	

5) Maintenance Plan

NO	Parameter	Range(default)	Notes
1	Countdown to oil change	0-5000h(5000h)	When it is set as 5000, then this function is disabled.
2	Air filter H	0-5000h(5000h)	
3	Fuel filter H	0-5000h(5000h)	
4	Oil filter	2000/01/01 -2099/12/31	When it is set as 2000/01/01, this function is

	replacement date		disabled.
5	Air filter D	2000/01/01-2099/12/31	
6	Fuel filter D	2000/01/01-2099/12/31	
7	engine oil filter expires action	0: Warn 1: Delayed alarm stop 2: Alarm and stop	engine action after the oil expires.
8	Air filter expiration action	0: Warn 1: Delayed alarm stop 2: Alarm and stop	engine action after the air filter expires.
9	Fuel filter expiration action	0: Warn 1: Delayed alarm stop 2: Alarm and stop	engine action after the fuel filter expires.
10	Maintenance due delay time	0-500.0h(1.0h)	If after the maintenance expires, after the engine starts successfully, after the set time, the maintenance expired shutdown alarm will be reported.

6)Limited time function

NO	Parameter	Range(default)	Notes
1	Factory limited time	0-5000h(5000h)	Set the accumulated time allowed by the manufacturer to run the engine. After the timer expires, the engine will not run. Entering a temporary password can ensure that the engine will start at one time. When set to 5000, this function is disabled.
2	Temporary password one	0-65535(11111)	After the manufacturer's time limit is set, the temporary password 1 will become invalid after one use;
3	Temporary password two	0-65535(22222)	After the manufacturer's time limit is set, the temporary password 2 will become invalid after one use;
4	Temporary password three	0-65535(33333)	After the manufacturer's time limit is set, the temporary password 3 will become invalid after one use;
5	Factory release password within a limited time	0-65535(44444)	After the manufacturer's time limit is set, enter this password to permanently unlock the password;

7)Display parameters

NO	Parameter	Range(default)	Notes
1	Start screen display time	0-20.0s (5.0s)	Start screen display time,0: No-display.
2	Backlight	20-100% (80%)	Back lightness adjustment.
3	Energy saving	5.0-6000.0s (600.0s)	LCD light will be closed automatically without any button pressed after delay. If setting as 6000.0s, back light always lighted.
4	Return home	5.0-600.0s (600.0s)	The time when the page reverts back to the home page. If setting as 600.0s: disabled.

5	Display LOGO delay	5.0-6000.0 (6000.0s)	Start screen will be opened without any button pressed after delay. If setting as 6000.0s: disabled.
6	Display UI selection	0: Dark mode 1: Bright mode	Set interface display mode.

8) USB/485

No	Parameter	Range(defaults)	Notes
1	Communication mode	0: Slave mode 1: Host mode	Select the meter communication mode, the host can read and display the parameters of the slave through the RS485 port.
2	Device address	1-255(16)	The IP built by meter and PC.
3	485 communication baud rate	0: 4800 1: 9600 2: 19200 3: 38400 4: 57600 5: 115200	RS485 communication baud rate.

a) Data/time setting

No	Parameter	Range(defaults)	Notes
1	Current date	2000/01/01-2099/12/31	Internal calendar, please calibrate regularly.
2	Current time	00:00:00-23:59:59	
3	Current week	Monday to Sunday	

b) Self-define curve

NO	Parameter	Notes
1	Self-define fuel level curve	Sensor curve can be User-defined by panel buttons, resistance and according value should be input, MAX 15 groups, MIN 2 groups.  Rule: resistance should be input from small to large.

12. Fault finding

Symptoms	Possible Solutions
meter no response with power	Check DC voltage. Check DC fuse.
meter does not respond to speed control	Check whether the meter mode is correct; Check whether the button function is normal; Check whether the connection and function of the rotary encoder are normal.
Sensor/switch alarm	Check whether the sensor/switch connection is normal, and whether the analog/switch connection is reversed; Check whether the sensor is damaged.
Shutdown Alarm in running	Check related switch and its connections according to the information on LCD. Check programmable inputs.
USB communication is abnormal	Check the USB connection. Check whether the USB port of the computer is normal. Check whether the USB driver is installed.

RS485 cannot communicate normally	Check the connection. Check if the communication ID number setting is correct. Check if the A and B lines of RS485 are reversed. Check if the RS485 communication line driver is installed or not. Check if the communication port of the PC is damaged. Add a 120 Ω resistor between the AB of the meter RS485.
CAN cannot communicate normally	Check the connection. Check whether the H and L wires of CAN are connected reversely. After adding 120 ohm resistance between the HL of the meter equipment CAN, try again. Check whether the ECU is normal.
ECU warning or stop	Get information from LCD of alarm page; If there is detailed alarm, check engine according to description. If not, please refer to engine manual according to SPN alarm code.