

# DC4xD MK4 GENSET CONTROLLER USER MANUAL

## DC40D MK4



## DC42D MK4



## Software Version

No.	Version	Date	Note
1	V1.0	2024-04-15	Original release.
2			
3			
4			
5			



Chongqing Mebay Technology Co.,Ltd

Add: No6-2,Building 4, Gangan Rd, Jiangbei District, Chongqing.

Tel:+86-23-6869 3061

Fax:+86-23-6765 8207

Web:<http://www.mebay.cn>



<http://www.cqmb.cn>

E\_mail:[sales@mebay.cn](mailto:sales@mebay.cn)

**Controller models to which this manual applies:**

DC40D MK4  
DC42D MK4  
DC40DR MK4  
DC42DR MK4  
DC42DR-ABF MK4

## Symbol Description

Symbol	Description
 Note	Remind operators to operate correctly, otherwise it may cause the equipment not to work correctly.
 Be care	It is indicated that potential hazards can damage equipment without proper precautions.
 Warning	It is indicated if appropriate preventive measures are not taken, potentially dangerous situations may result in death, serious personal injury or significant property losses.

**Warning**

1. The installation of this equipment must be carried out by professionals.
2. When installing and operating the controller, please read the entire instruction manual first.
3. Any maintenance and commissioning of the equipment must be familiar with all the equipment.
4. Safety standards and precautions in advance, otherwise it may cause personal injury or damage to related equipment.
5. The engine must have an overspeed protection device independent of the controller system to avoid casualties or other damage caused by engine out of control.
6. After the installation of the controller is completed, please verify that all protection functions are valid.

**Be Care**

1. Please keep the good connection of the power supply of the controller. Do not share the connection lines of the positive and negative electrodes of the battery with the floating charger.
2. During the operation of the engine, do not disconnect the battery, otherwise it may cause damage to the controller.

## Catalogue

1. Summary .....	6
2. Main Features .....	6
3. Parameters Display .....	7
4. Protection .....	7
5. Parameters .....	8
6. Overall Dimension and Wiring Diagram .....	6
7. Installation instruction .....	17
8. Panel and display .....	18
9. Control and operation instruction .....	19
10. Warnings and Shutdown Alarms .....	24
11. Parameters setting .....	31
12. Fault finding .....	44



### Notes:

1. All rights reserved. No part of this duplication may be reproduced in any material form (including photocopying or storing in any medium by electronic means or others) without the written permission of the copyright holder.
2. MEBAY Technology reserves the rights to change the contents of this document without prior notice.

## 1. Summary

This series controller is specialized for Diesel / Gasoline / Gas Genset Start, Stop, Parameters monitoring, faults-checking as well as data setting.

3.0 inch colorful LCD screen display with brand new UI design is adapted in this controller that the relative failures can be displayed directly. All the parameters can be displayed by simulated indicators and words. Besides, LCD screen can display various faults in the same time that the genset will be stopped once it can't work smoothly.

There are Chinese/English interface options, more language can be set according to user's request. All the parameters can be configured through the front face buttons or use programmable interface by USB\RS485 to adjust via PC. It can be widely applied for all kinds of auto control system of gensets.

## 2. Main Features

There are five Models under DC40D MK4 series.

Model	USB	RS485	AMF	ABF
DC40D MK4	●	—	—	—
DC42D MK4	●	—	●	—
DC40DR MK4	●	●	—	—
DC42DR MK4	●	●	●	—
DC42DR-ABF MK4	●	●	●	●

- ◆ 32bit high performance single chip microcomputer.
- ◆ 3.0 inch 128 \* 64 high-resolution screen LCD, Available in 16 languages, user's language set if necessary.
- ◆ Adopting PC material panel, effectively waterproof, oil-proof, UV-proof, good operating feel and long service life.
- ◆ AMF: Mains monitoring and AMF (Mains/Generator automatic switching control), especially suitable for the automation system composed by mains and genset.
- ◆ ABF function: automatically starts and stops the genset by monitoring the backup battery pack;
- ◆ Various of crank conditions (RPM, Frequency, Oil Pressure) can be chosen.
- ◆ Adapt to 3P4W,1P2W,2P3W(120V/240V,50/60HZ)
- ◆ Sensor can be self-defined by front face button or PC software.
- ◆ USB Port: parameters can be set even without power through USB port to monitor in real time.
- ◆ With RS485 communication port, can achieve "Three Remote" functions via MODBUS protocol.
- ◆ Input/output function, status can be shown directly.
- ◆ More categories of surface setting.
- ◆ Real time clock inside: preset time operate and auto maintenance is available. Genset working plan can be set as per week or month.
- ◆ Maintenance countdown function, which can set the maintenance time or date.
- ◆ The black box function can save the relevant parameters of the unit when the fault alarm occurs in real time, and it is convenient to find the cause of the fault.
- ◆ **Has an operation log function that can save 5000 user operation records;**
- ◆ **It has an running record function, which can save 5000 genset running records;**
- ◆ Totally 6 relay's output, among which 4 relay output can be self-configurable, each relay can be set as max 30 functions, besides, there are 2 groups as non-contact terminals.
- ◆ With 5 switches input, up to 10 functions optional;

- ◆ 3 sensor simulation input connectors, and various display units can be configured.
- ◆ Control Protection: Auto Start/Stop of genset, load transfer (ATS control) and perfect failure display and protection.
- ◆ Standard water-proof rubber gasket. The waterproof can reach IP65.
- ◆ Module design: All the connections are adapted with European connectors so that installation, connection, repair and replacement can be more easily.

### 3. Parameters Display

- ◆ Engine RPM
- ◆ Engine oil pressure
- ◆ Engine water temperature
- ◆ Engine oil temperature
- ◆ Engine cylinder temperature
- ◆ Engine fuel level
- ◆ Engine battery voltage
- ◆ Charging voltage
- ◆ UPS battery voltage (only for DC42DR-ABF MK4)
- ◆ Mains Frequency (only for 42 series)
- ◆ Mains phase voltage L-N (only for 42 series)
- ◆ Mains phase voltage L-L (only for 42 series)
- ◆ Generator 3 Phase voltage L-N
- ◆ Generator 3 Phase voltage L-L
- ◆ Generator 3 phase current A
- ◆ Generator Frequency Hz
- ◆ Generator Power Factor COS  $\phi$
- ◆ Generator active power KW
- ◆ Generator apparent power KVA
- ◆ Generator reactive power KVar
- ◆ Real-time load rate %
- ◆ Current consumption KWH
- ◆ Total consumption KWH
- ◆ Total Crank times
- ◆ Current running time
- ◆ Total running time
- ◆ Maintenance notice
- ◆ Switches input status display
- ◆ Output status display of relays
- ◆ Current date/time

### 4. Protection

- ◆ Over speed
- ◆ Under speed
- ◆ Low oil pressure
- ◆ High water temperature
- ◆ High Oil temperature
- ◆ High Cylinder Temperature
- ◆ Low fuel level
- ◆ Low oil level
- ◆ External instant unloading shutdown
- ◆ RPM Lost
- ◆ Sensor Open
- ◆ Over Frequency
- ◆ Under Frequency



- ◆ Over voltage
- ◆ Under voltage
- ◆ Over current
- ◆ Non-balance of current
- ◆ Over power
- ◆ Gens out of phase
- ◆ Maintenance expire
- ◆ Low water level alarm
- ◆ External emergency alarm
- ◆ Louver opening exception
- ◆ Emergency Stop
- ◆ Crank failure
- ◆ Stop Failure
- ◆ Battery over voltage
- ◆ Battery under voltage
- ◆ The charger fails to charge

## 5. Parameters

Options	Parameters
Working voltage	DC8V---36V Continuous
Power consumption	Standby:24V:MAX 1W
	Working:24V:MAX 5W
AC Voltage Input	1P2W 30VAC-360VAC (ph-N)
	2P3W 30VAC-360VAC (ph-N)
	3P4W 30VAC-360VAC (ph-N)
Rotate speed sensor Frequency	1-10000Hz
MAX Accumulating Time	99999.9Hours (Min Store time:6min)
Fuel Relay Output	Max 5Amp DC+VE Supply voltage
Start Relay Output	Max 5Amp DC+VE Supply voltage
AUX. Output 1	Max 5Amp DC+VE Supply voltage
AUX. Output 2	Max 5Amp DC+VE Supply voltage
AUX. Output 3	250V/5 AMP Non-contact normally Open output
AUX. Output 4	250V/3 AMP Non-contact normally Closed output
Excitation output	DC+VE supply voltage
Switch value input	Available if connecting with Battery -
Battery pack voltage input	0-100VDC(only for DC42DR-ABF MK4)
USB	Type-B
RS485	Isolated Modbus-RTU protocol
Working condition	-25°C ~+65 °C
Storage condition	-40-85°C
Protection Level	IP65:when waterproof rubber gasket is added between controller and its panel
Insulation strength	Apply AC2.2kV voltage between high voltage terminal and low voltage terminal; The leakage current is not more than 3mA within 1min.
Overall dimension	189mm×134mm×50mm
Panel cutout	160mm×120mm
Weight	0.68Kg

6. Overall Dimension and Wiring Diagram

◆ Overall Dimension:

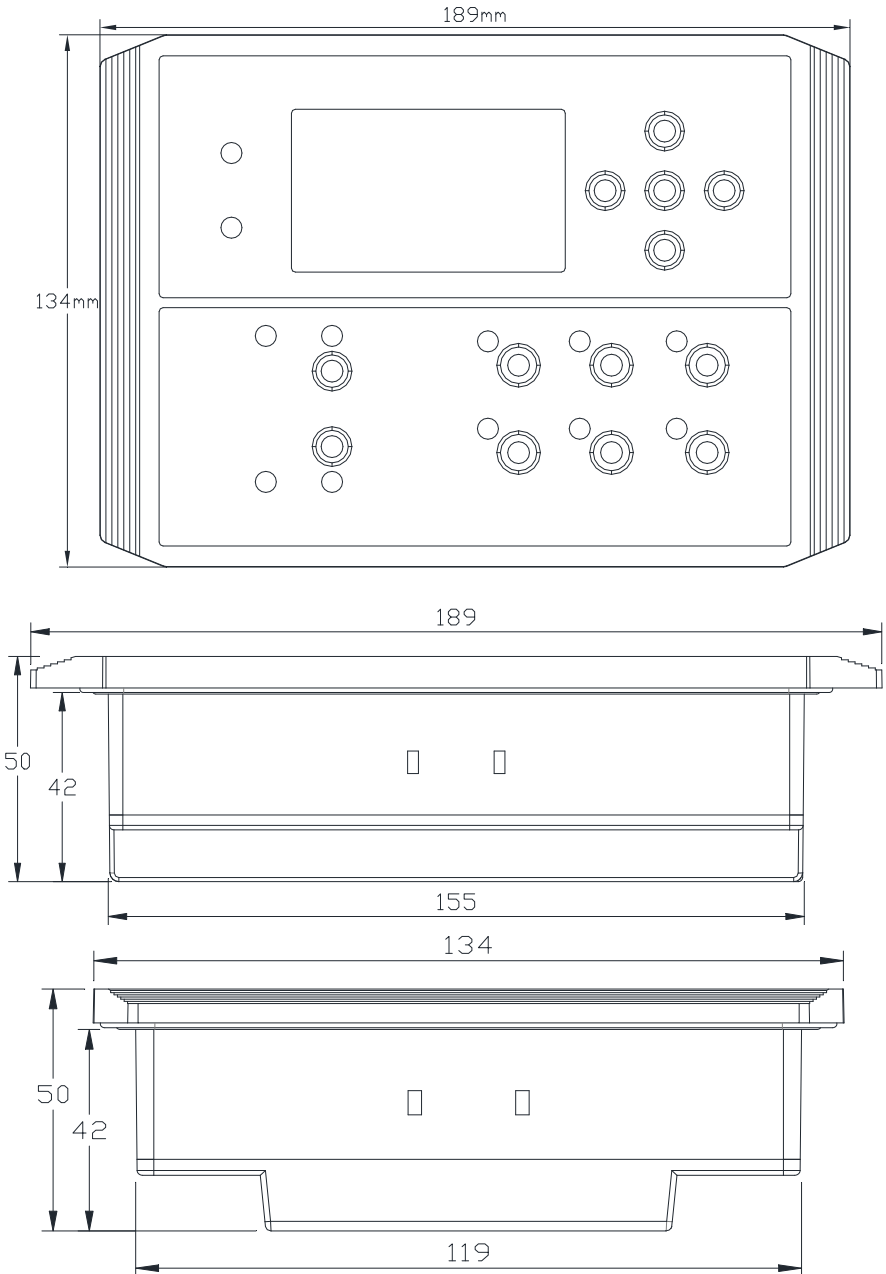

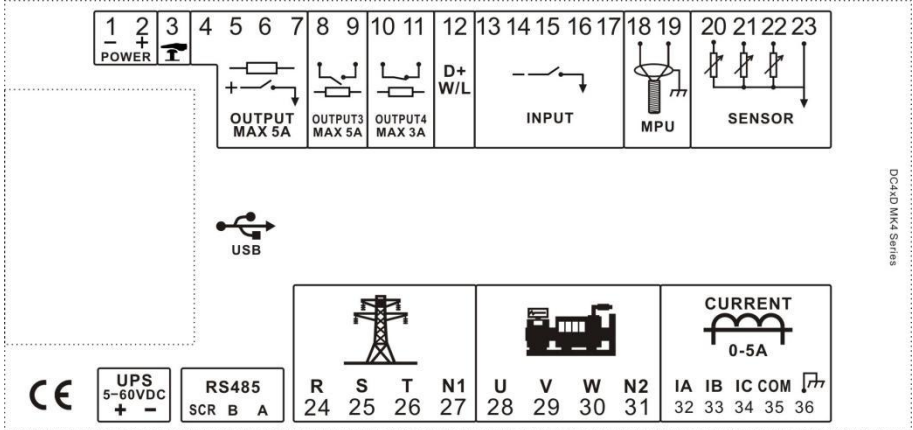
**◆ Descriptions of terminal connection**

No.	Function	Description	Cable cross sectional area
1	Battery Negative Input B-	Controller power supply input B-.	2.5mm <sup>2</sup>
2	Battery Negative Input B+	Controller power supply input B+.	2.5mm <sup>2</sup>
3	Emergency Stop Input	B+ voltage input is active, and connected to emergency stop normal closed button.	2.5mm <sup>2</sup>
4	Fuel Output	Active output, Max 5Amp	1.5mm <sup>2</sup>
5	Crank Output	Active output, Max 5Amp.	1.5mm <sup>2</sup>
6	AUX. OUTPUT1	Active output, Max 5Amp.	1.5mm <sup>2</sup>
7	AUX. OUTPUT2	Active output, Max 5Amp.	1.5mm <sup>2</sup>
8	AUX. OUTPUT3 Normal open	Passive normally open output, Max 5Amp.	1.5mm <sup>2</sup>
9	AUX. OUTPUT3 Normal open		1.5mm <sup>2</sup>
10	AUX. OUTPUT4 Normal close	Passive normally closed output, Max 3Amp.	1.5mm <sup>2</sup>
11	AUX. OUTPUT4 Normal close		1.5mm <sup>2</sup>
12	Charging excitation output	DC+VE supply voltage.	1.0mm <sup>2</sup>
13	Aux. Input 1	The grounding is valid according to the function selection switch input.	1.0mm <sup>2</sup>
14	Aux. Input 2		1.0mm <sup>2</sup>
15	Aux. Input 3		1.0mm <sup>2</sup>
16	Aux. Input 4		1.0mm <sup>2</sup>

17	Aux. Input 5		1.0mm <sup>2</sup>
18	Speed sensor +	Use a shielded wire to connect the speed sensor.	1.0mm <sup>2</sup>
19	Speed sensor -		1.0mm <sup>2</sup>
20	Aux. Sensor 1	Sensor input types can be configured as: disabled, oil pressure sensor, water temperature sensor, oil temperature sensor, cylinder temperature sensor, oil level sensor.	1.0mm <sup>2</sup>
21	Aux. Sensor 2		1.0mm <sup>2</sup>
22	Aux. Sensor 3		1.0mm <sup>2</sup>
23	Sensor common GND	Connect the battery negative or outer.	1.0mm <sup>2</sup>
24	Mains Voltage R	Connected to the mains U phase.	1.0mm <sup>2</sup>
25	Mains Voltage S	Connected to the mains V phase.	1.0mm <sup>2</sup>
26	Mains Voltage T	Connected to the mains W phase. Connected to the mains N phase.	1.0mm <sup>2</sup>
27	Mains Voltage N1		1.0mm <sup>2</sup>
28	Generator Voltage U	Connected to the power generation output R phase.	1.0mm <sup>2</sup>
29	Generator Voltage V	Connected to the power generation output S phase.	1.0mm <sup>2</sup>
30	Generator Voltage W	Connected to the power generation output T phase.	1.0mm <sup>2</sup>
31	Generator Voltage N2	Connected to the power generation output N phase.	1.0mm <sup>2</sup>
32	Load CT Secondary IA	Current Transformer Secondary Rated 5A.	1.5mm <sup>2</sup>
33	Load CT Secondary IB		1.5mm <sup>2</sup>
34	Load CT Secondary IC		1.5mm <sup>2</sup>
35	Load CT Secondary ICOM	Connect to the common GND instead of the neutral line N.	1.5mm <sup>2</sup>
36	Load CT Secondary EARTH	Connect to the common EARTH.	1.5mm <sup>2</sup>
SCR	RS485 SCR	A 120 Ω shielded wire and good grounding are recommended.	1.0mm <sup>2</sup>
B	RS485 B		1.0mm <sup>2</sup>
A	RS485 A		1.0mm <sup>2</sup>
+	UPS battery pack positive	Connected to the can communication port of ECU.	1.0mm <sup>2</sup>
—	UPS battery pack negative		1.0mm <sup>2</sup>

◆ DC40D MK4 3-phase 4-wire Typical Wiring Diagram

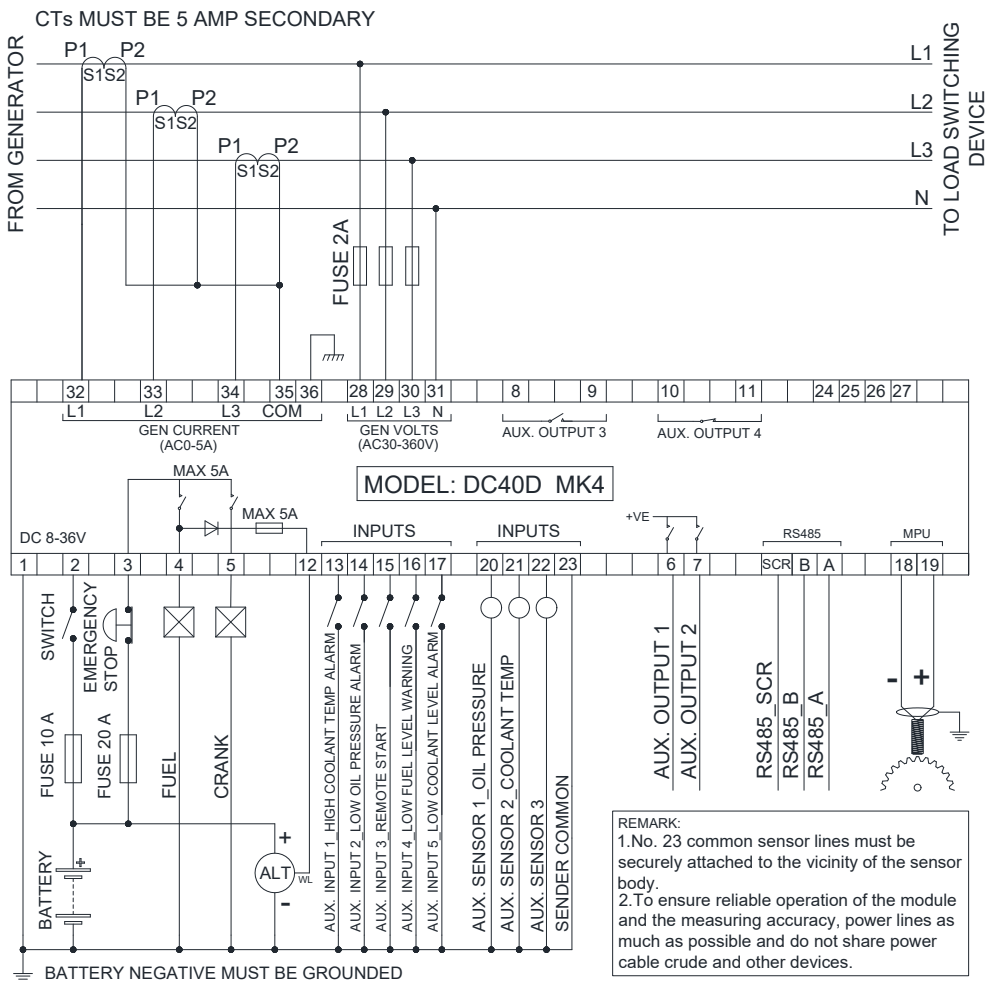

To ensure reliable operation of the module and the measuring accuracy, power lines as much as possible and do not share power cable crude and other devices.

**Note: Please don't move battery during running status or it may cause the controller broken!**

**WARNING:** When generator is on-load, C. T. secondary must not be open circuit, Otherwise, the high voltage generated will pose a danger to personal safety.

◆ DC42D MK4 3-phase 4-wire Typical Wiring Diagram

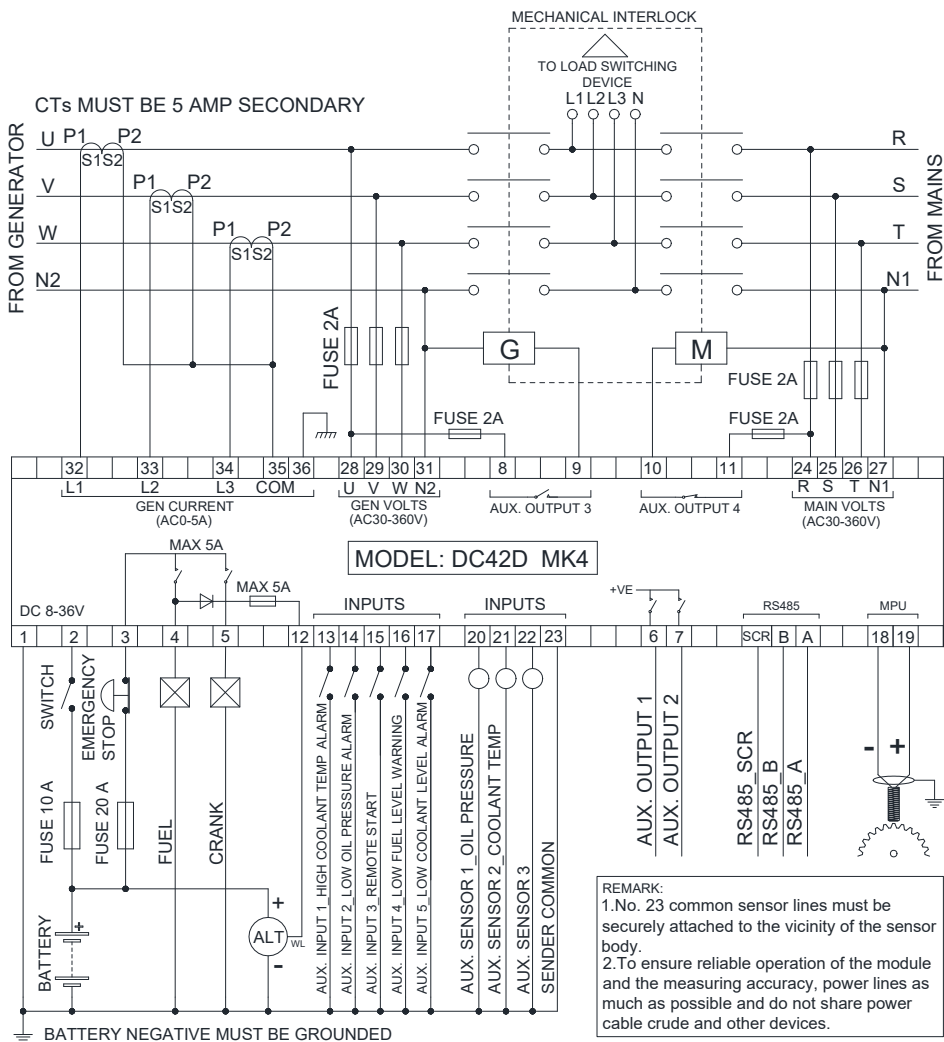

To ensure reliable operation of the module and the measuring accuracy, power lines as much as possible and do not share power cable crude and other devices.



**Note: Please don't move during running status or it may cause the controller broken!**



**WARNING:** When generator is on-load, C. T. secondary must not be open circuit, Otherwise, the high voltage generated will pose a danger to personal safety.

◆ DC42DR-ABF MK4 3-phase 4-wire Typical Wiring Diagram

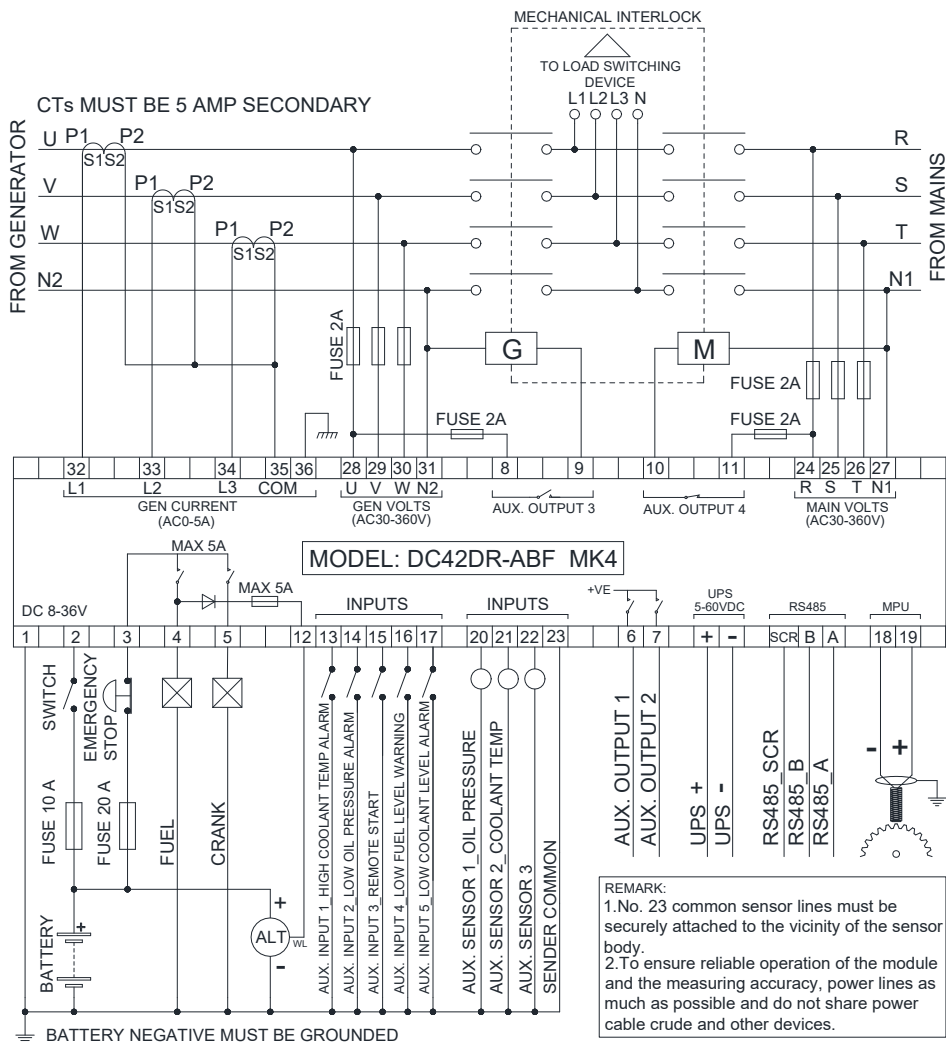

To ensure reliable operation of the module and the measuring accuracy, power lines as much as possible and do not share power cable crude and other devices.



**Note: Please don't move during running status or it may cause the controller broken!**



**WARNING:** When generator is on-load, C. T. secondary must not be open circuit, Otherwise, the high voltage generated will pose a danger to personal safety.

◆ DC40D MK4 1-phase 2-wire Typical Wiring Diagram

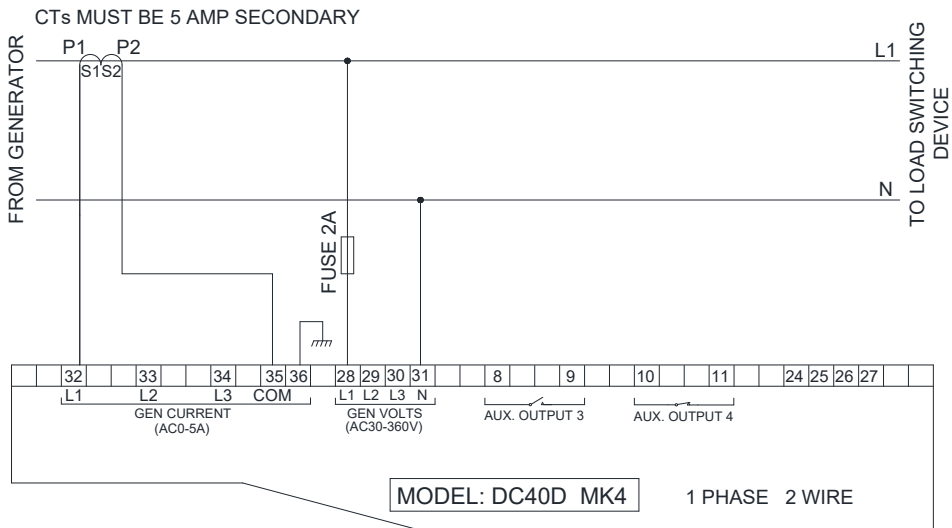

◆ DC42D MK4 1-phase 2-wire Typical Wiring Diagram

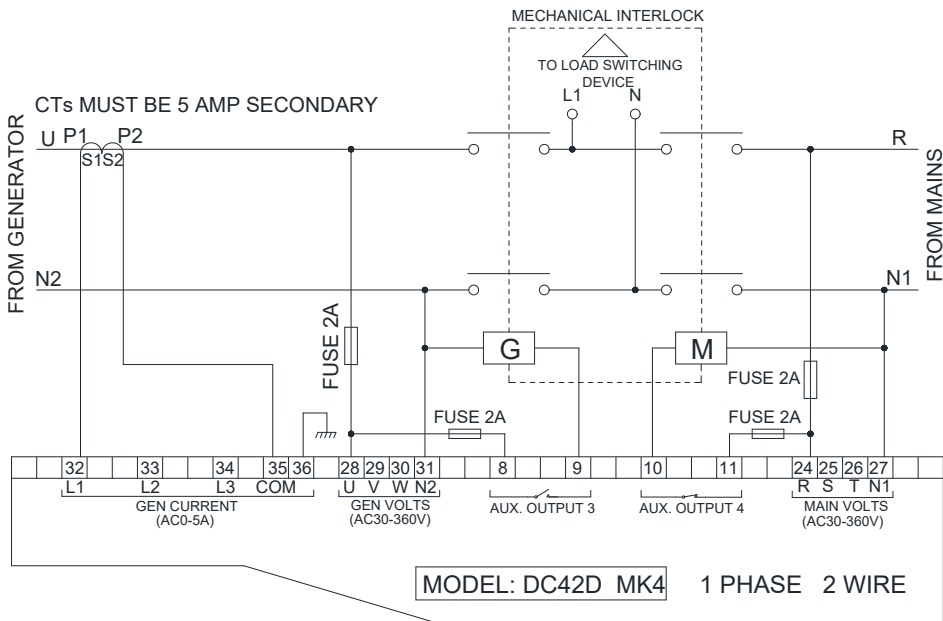



◆ **DC40D MK4 2-phase 3-wire Typical Wiring Diagram**

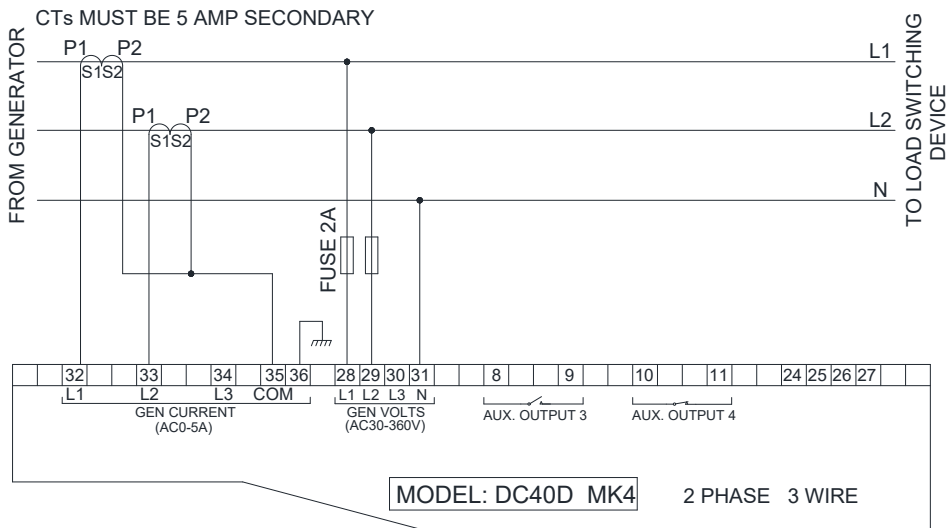

◆ **DC42D MK4 2-phase 3-wire Typical Wiring Diagram**

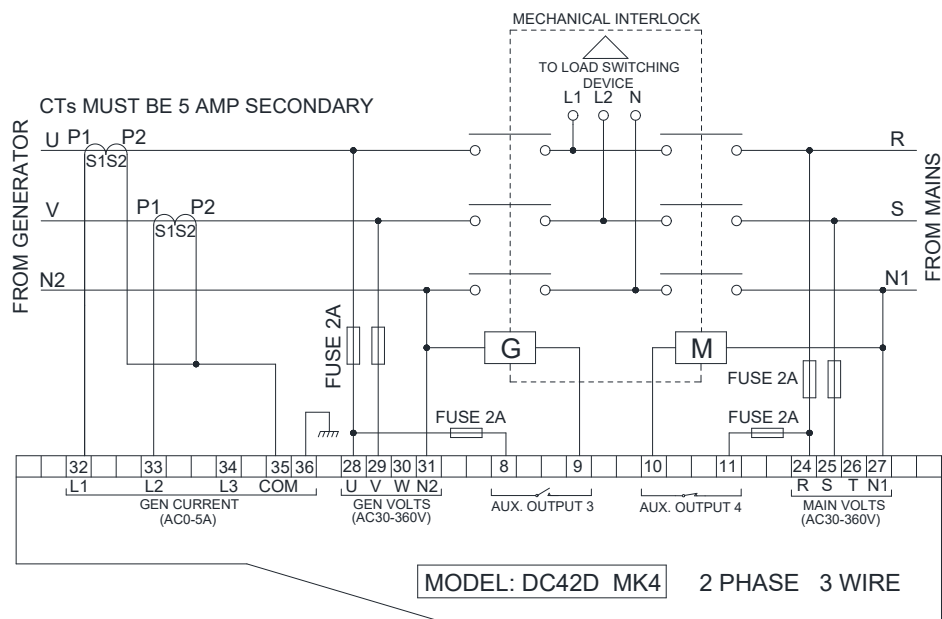

## 7. Installation instruction

- ◆ The controller is fixed by four special fixing members and screws, and the screws of the metal fasteners cannot be too tight.
- ◆ Panel Cutout: W160mm\*H120mm.

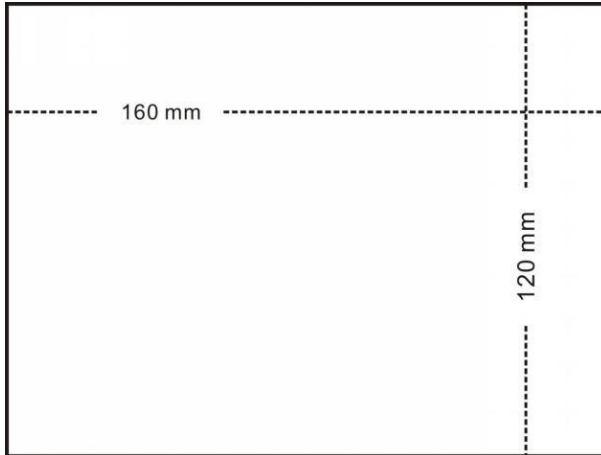

**Note:** If the controller is installed directly in the genset shell or other fluctuated equipment, the rubber pad must be installed.

### ◆ Battery Voltage Input

DC4xD MK4 controller is suitable for 8-36V DC battery voltage. Battery negative must be reliably connected to the enclosure of the engine. The controller power supply B+ and B- must be connected to battery positive and negative, and the wire size must not be less than 2.5mm<sup>2</sup>.



NOTE:

In case of floating charger connect charger output to battery positive and negative directly, then, connect battery positive and negative poles to controller positive and negative power supply.

### ◆ Output and relay expansion



Note: All outputs of the controller are relay contacts. The maximum current capacity is described in the "Parameters" in this manual. Please use it in the relay current capacity. If an extended relay is needed, add a continuous current diode (when the extended relay coil is DC) or a resistance-capacitance loop (when the extended relay coil is AC) to both ends of the coil to prevent interference with the controller or other equipment.

### ◆ AC current input

Current transformer with rated secondary current 5A must be externally connected to the controller current input.



Note: The common terminal ICOM of the current transformer should be connected to the common earth of the equipment; and it cannot be connected to the zero line N, otherwise the controller may be damaged.



**WARNING:** When generator is on-load, C. T. secondary must not be open circuit, Otherwise, the high voltage generated will pose a danger to personal safety.

◆ **Withstanding voltage test**



If withstanding voltage test is conducted after the controller has already been installed onto the control panel, please unplug all controller terminal connections in order to prevent high voltage from damaging it.

**8. Panel and display**

◆ **DC40D MK4**

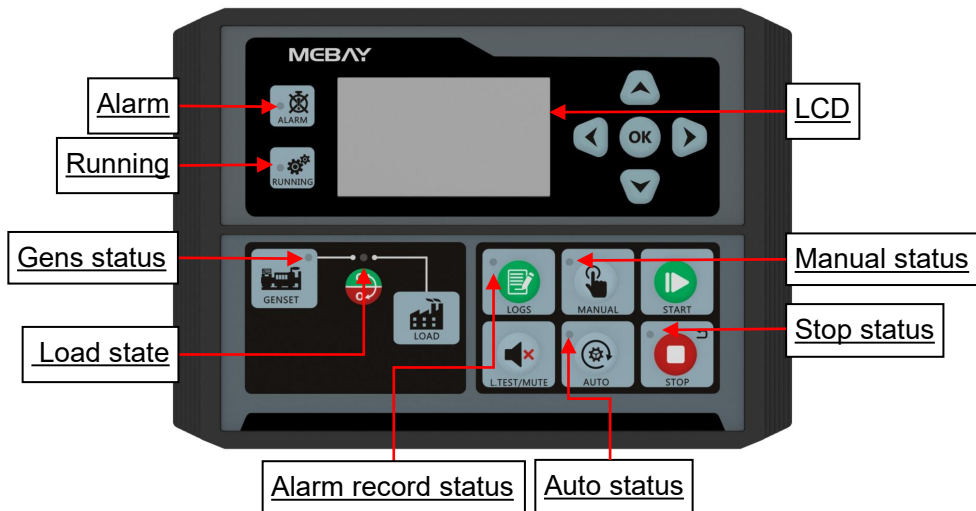



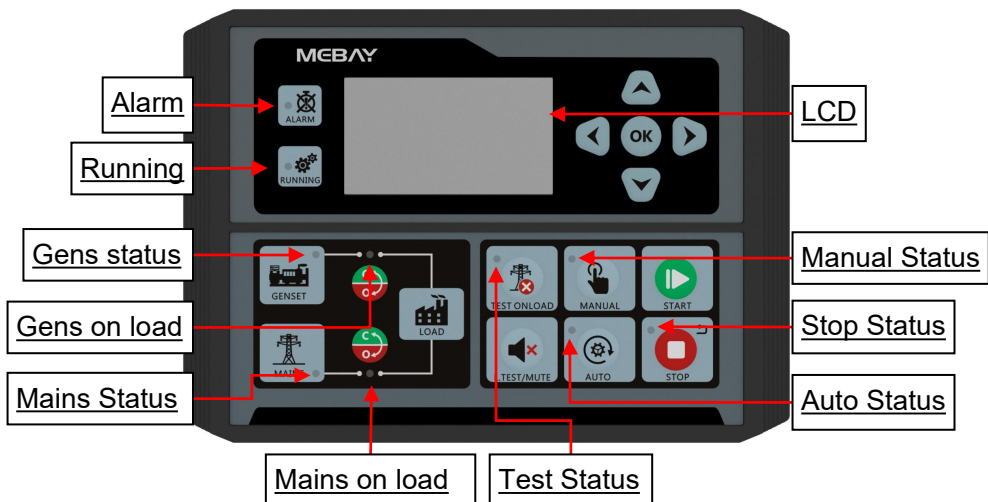







◆ **DC42D MK4**



## 9. Control and operation instruction

### ◆ Key Function Description

KEYS	NAME	Main Function
	Stop Reset Revert	<ul style="list-style-type: none"> <li>◆ Can stop generator under manual/auto mode;</li> <li>◆ Can reset shutdown alarm</li> <li>◆ During stop procession, pressing this key again can stop generator immediately.</li> <li>◆ Pressing this key can cancel the setting and back to upper class under edition.</li> <li>◆ Under the setting mode with checking data, the data can be saved and system will exit after pressing.</li> </ul>
	Start	<ul style="list-style-type: none"> <li>◆ Start the genset under manual mode.</li> <li>◆ Pressing this key can start the genset under manual testing mode.</li> </ul>
	Manual	<ul style="list-style-type: none"> <li>◆ Pressing this key will set the module into manual mode.</li> </ul>
	Auto	<ul style="list-style-type: none"> <li>◆ Pressing this key will set the module into auto mode.</li> </ul>
	DC40D MK4 Records	<ul style="list-style-type: none"> <li>◆ Pressing this key to check the alarm records under stop mode.</li> </ul>
	DC42D MK4 Test	<ul style="list-style-type: none"> <li>◆ Pressing this key to come into manual testing mode.</li> <li>◆ Under testing mode, pressing MANUAL can start the genset and transfer to normal loading after running which is to test if the auto start is in normal status.</li> </ul>
	LED Test/ Warning clear	<ul style="list-style-type: none"> <li>◆ Test if all LED lights are ok, pressing this key to test if all lighted, all off when loosen it.</li> <li>◆ Under warning, pressing this key can clear warning and controller will re-check warning.</li> <li>◆ Under alarm, pressing this key can clear the buzzer call.</li> <li>◆ Pressing this key in 3 seconds can clear the buzzer call, pressing it again in 3 seconds can recover the buzzer call.</li> </ul>
	Gens/ Mains Close/On	<ul style="list-style-type: none"> <li>◆ Under manual mode, pressing this key can transfer load to genset/mains.</li> </ul>
	Left	<ul style="list-style-type: none"> <li>◆ Under display mode, pressing this key to turn left page.</li> <li>◆ Under edition mode, pressing this key to move the digit.</li> </ul>
	Right	<ul style="list-style-type: none"> <li>◆ Under display mode, pressing this key to turn right page.</li> <li>◆ Under edition mode, pressing this key to move the digit.</li> </ul>
	Up	<ul style="list-style-type: none"> <li>◆ Under display mode, parts of the page can move up.</li> <li>◆ Under edition mode, pressing this key to move the digit or increase the numbers.</li> <li>◆ Under records mode, pressing this key to move the digit.</li> </ul>

	Down	<ul style="list-style-type: none"> <li>◆ Under display mode, parts of the page can move down.</li> <li>◆ Under edition mode, pressing this key to move the digit or decrease the numbers.</li> <li>◆ Under records mode, pressing this key to move the digit.</li> </ul>
	OK	<ul style="list-style-type: none"> <li>◆ Confirm the change under edition mode.</li> <li>◆ Page exited under records checking mode.</li> <li>◆ In display mode, press to return to the display home page.</li> <li>◆ In standby state, press for 3 seconds to enter the parameter setting mode.</li> </ul>
	Setting mode	<ul style="list-style-type: none"> <li>◆ Pressing OK and STOP simultaneously to come into setting mode</li> </ul>
	DC42D MK4 Alarm Records checking	<ul style="list-style-type: none"> <li>◆ Pressing STOP and RIGHT to check the records and any buttons pressed to exit from the page.</li> </ul>

#### ◆ Engine flywheel teeth automatic adjustment

- 1) Crank disconnect must be set to include both "speed" and "frequency" options.
- 2) When the generator frequency and engine speed are not zero, press and for more than 0.5 seconds, the controller will automatically calculate and save the number of flywheel teeth according to the generation frequency and generator poles.
- 3) After calculating and saving the number of flywheel teeth successfully, the controller shows: "**Flywheel xxx teeth, saved successfully!**"

#### ◆ Alarm records checking

DC4xD MK4 controller can save 100 groups of alarm records which contains the alarm record data includes detailed data such as alarm time, generator parameters, engine parameters, etc.









How to check the alarm records:

- 1) Enter alarm record page:
  - a) DC40D MK4: under stop mode, press to come into alarm records page;
  - b) DC42D MK4: press and simultaneously to come into alarm records page;
- 2) Press to turn upper digit and press to turn lower digit in order to choose the record you need. Press to confirm the record and come into history records checking page.
- 3) Press to turn lower records under records checking page. Press to turn upper records and press to revert back to alarm history records page.
- 4) Exit from records page: In the history records page and checking page, press to exit.

#### ◆ View controller system log

DC4xD MK4 series generator set controller can save 5000 system logs, including operation time, generator set startup, key operation, parameter modification, controller power on and other records.







The steps to view the system log are as follows:

- 1) Press the key  for more than 3 seconds. Or press the stop key  without releasing, press the OK key  again, and then release all the keys to enter the setting menu page;
- 2) In the setting menu page, select "**System logs**" and press the OK key  to enter the password input page;
- 3) Enter the controller parameter setting password, and the default factory password is "**07623**"; after entering the password, press the OK key  once to enter the system log page;
- 4) In the system log page, press the up key  and down key  to browse the operation log, and the latest operation is recorded in the front; press the STOP key  to exit the system log page.

#### ◆ System Operational Records



DC4xD MK4 controller can save 5000 system operation records, including power-on time, date, cumulative time, starting mode (manual, automatic, unknown, ), running time, stopping mode (manual, automatic, alarm stop, unknown), and writing running time and mode at 6-minute intervals.

The steps to view the system log are as follows:

- 1) Press the key  for more than 3 seconds. Or press the stop key  without releasing, press the OK key  again, and then release all the keys to enter the setting menu page;
- 2) In the setting menu page, select "**System Operational Records**" and press the OK key  once to enter the System Operational Records page;
- 3) In the System Operational Record page, press the up key  and down key  to browse the operation log, and the latest operation is recorded in the front; press the STOP key  to exit the System Operational Records page.

#### ◆ Maintenance expiry reset password

The controllers are equipped with a quick reset maintenance countdown function, which is operated as follows:

- 1) Press the key  for more than 3 seconds to enter the setting menu interface.
- 2) In the setting menu interface, press  key to move down, select "Maintenance Countdown Reset", and input "Maintenance Countdown Reset Password".
- 3) In the pop-up dialogue box, select "Yes", the controller will reset the maintenance countdown to the set value.
- 4) After the maintenance countdown is reset successfully, the controller will exit the setting interface automatically.





Note: The maintenance countdown password cannot be set as the same as the parameter setting password!

◆ **Manual test mode: (only DC42D MK4 has this function)**

press  and make sure it is in the stop position before starting.

Press  and the test file indicator is on. At this time, it is detected whether the connection of each sensor is normal. If the sensor is open, the sensor opens an alarm. If it is normal, the unit start process is executed in the following sequence after

pressing the . automatically switch to Generator provide the power when the

unit is running normally. Press  The controller performs the parking process at the following timing:

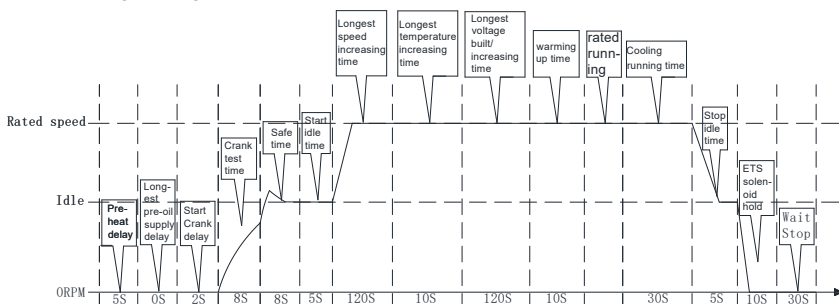

◆ **Manual Start Mode**

press  and make sure it is in the stop position before starting.

Press  and the test file indicator is on. At this time, it is detected whether the connection of each sensor is normal. If the sensor is open, the sensor opens an alarm. If it is normal, the unit start process is executed in the following sequence after

pressing the . automatically switch to Generator provide the power when the

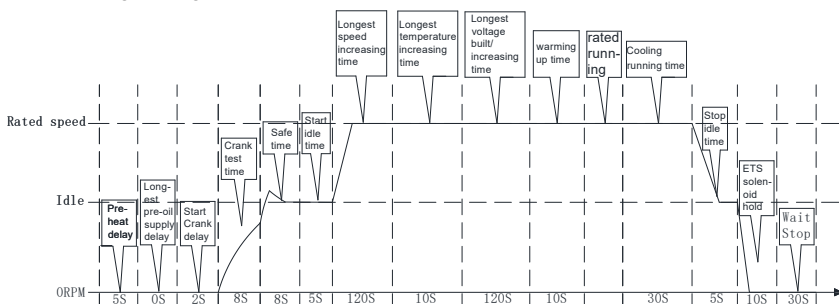

unit is running normally. Press  The controller performs the parking process at the following timing. Manual start and stop process:

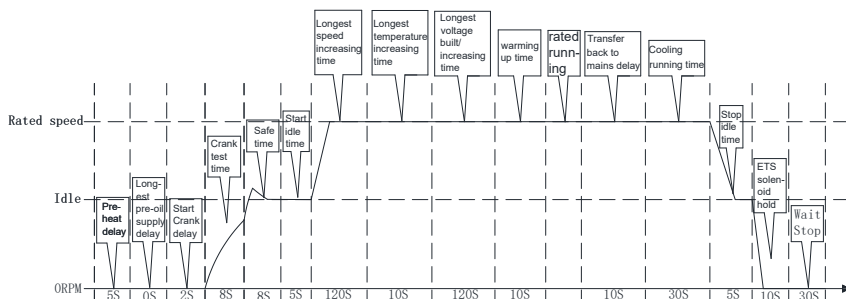

After the manual start is successful, pressing the "automatic key" can be converted into an automatic file. The specific working time is as follows:



### ◆ Emergency Start

In the manual mode, press the "manual"  button and the "start"  button at the same time to start the generator set in case of emergency. At this time, the controller does not judge whether the engine has been started successfully according to the successful starting conditions. The disengagement of the starter must be controlled by the operator. When the operator observes that the unit has been started successfully, release the key, the starter stops output, and the controller enters the safety delay.

### ◆ Automatic starting mode:

press  and make sure it is in the stop position before starting.

Press "" and the test file indicator is on. At this time, it is detected whether the connection of each sensor is normal. If the sensor is open, the sensor opens an alarm. If it is normal, wait for the remote start signal to be valid (DC42D MK4 detected the remote starting signal is valid or the mains provide the power is invalid). The unit will perform the starting process in the following sequence. When the unit enters the normal rated operation, it will automatically switch to the generator provide the power. The controller will detect the remote start signal and the mains status in real time (DC42D MK4 is available). When the remote start signal fails and the mains provide the power returns to normal, the shutdown process after the "loop time delay" is performed (DC42D MK4 is available).

Auto start and stop process:

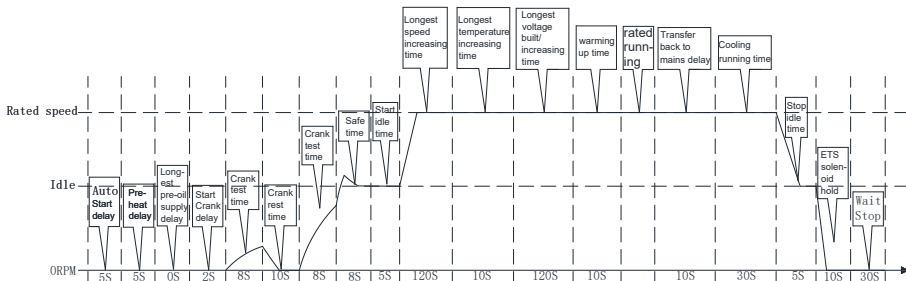

### ◆ Notices in Starting Process



Note 1: During the Cranking time, the controller automatically detects the speed



signal, frequency signal and oil pressure value or the charging voltage (according to the parameter setting) to reach the judgment condition of successful start, then the judgment is that the start is successful and the motor relay is closed.



Note 2: Within the safety delay, only respond to emergency stop, immediate stop, over speed, over frequency, Over voltage, ECU communication Failure, shutter open abnormal, other alarms are not responded to.



Note 3: No response to alarm and warning of under speed, low frequency, under voltage, over current, over power, non-balance of current, external instant unloading shutdown, during start idle time.



Note 4: No response to low frequency, under voltage, over current non-balance of current, external instant unloading shutdown and over power is required when entering the RPM-up time.



Note 5: No response to low frequency, under voltage, over current non-balance of current, external instant unloading shutdown and over power is required when entering the temperature-up time.



Note 6: No response to low frequency, under voltage, over current non-balance of current, external instant unloading shutdown and over power is required when entering the Voltage-up time.



Note 7: No response to low frequency, under voltage, over current non-balance of current, external instant unloading shutdown and over power is required when entering the Warming-up time.



Note 8: After entering rated operation, the Gens load relay output.



Note 9: In the process of shutdown, if the remote starting signal is restored to be valid within the "Cooling time", the rated operation will be entered again.



Note 10: If the stop key is pressed again during idle time, the idle time will be canceled and the stop operation will be executed directly.

## 10. Warnings and Shutdown Alarms

### ◆ Warnings



Notes: Warning is a non-serious failure state, which will not harm the gensets system for the time being. It only reminds operators to pay attention to the situation that does not meet the requirements and solve it in time to ensure the continuous operation of the system. When the warning occurs, the gensets does not stop. Once the fault is removed, the warning is automatically canceled.

#### Low fuel level switch warning

When the controller detects that the AUX. Input "Low fuel level warning input" switch is active, it starts warning delay and lasts for Normal alarm delay. When the "Low fuel level warning input" switch is enabled, the engine low fuel level switch

warning is reported. **"ALARM"** lights will light up, Generators will not stop, displays **"Low fuel level-D"** on the current fault screen.

### External instant warning

When the controller detects that the AUX. Input **"External instant warning input"** switch is active, it starts warning delay and lasts for Normal alarm delay. When the **"External instant warning input"** switch is enabled, the warning is reported. **"ALARM"** lights will light up, Generators will not stop, displays **"Instant warn"** on the current fault screen.

### Low coolant level switch warning

When the controller detects that the AUX. Input **"Low water level warning"** switch is active, it starts warning delay and lasts for Normal alarm delay. When the **"Low water level warning"** switch is enabled, the engine low coolant level switch warning is reported. **"ALARM"** lights will light up, Generators will not stop, displays **"Low water level"** on the current fault screen.

### Low fuel level sensor warning

When the controller detects that the fuel level value is lower than the **"Low fuel level warning"**, Then start warning delay and the duration (Normal alarm delay) have not returned to normal, the warning of Low fuel level warning is reported. **"ALARM"** lights will light up, Generators will not stop, displays **"Low fuel level"** on the current fault screen.

### Oil pressure sensor disconnected warning

When the controller parameter **"Action if low oil pressure sensor disconnected"** is set to **"warning"**, When the oil pressure sensor is detected to be disconnected, Then start warning delay and the duration (Normal alarm delay) have not returned to normal, the warning of Oil pressure sensor disconnected warning is reported. **"ALARM"** lights will light up, Generators will not stop, displays **"OP sensor open"** on the current fault screen.

### Coolant temperature sensor disconnected warning

When the controller parameter **"Action if water temperature sensor disconnected"** is set to **"warning"**, When the coolant temperature sensor is detected to be disconnected, Then start warning delay and the duration (Normal alarm delay) have not returned to normal, the warning of coolant temperature sensor disconnected warning is reported. **"ALARM"** lights will light up, Generators will not stop, displays **"WT sensor open"** on the current fault screen.

### Oil temperature sensor disconnected warning

When the controller parameter **"Action if oil temperature sensor disconnected "** is set to **"warning"**, When the oil temperature sensor is detected to be disconnected, Then start warning delay and the duration (Normal alarm delay) have not returned to normal, the warning of oil temperature sensor disconnected warning is reported. **"ALARM"** lights will light up, Generators will not stop, displays **"OT sensor open"** on the current fault screen.

### Cylinder temperature sensor disconnected warning

When the controller parameter **"Action if cylinder temperature sensor**

**disconnected** " is set to **"warning"**, When the cylinder temperature sensor is detected to be disconnected, Then start warning delay and the duration (Normal alarm delay) have not returned to normal, the warning of cylinder temperature sensor disconnected warning is reported. **"ALARM"** lights will light up, Generators will not stop, displays **"CT sensor open"** on the current fault screen.

#### Fuel Level sensor disconnected warning

When the controller parameter **"Action if fuel Level sensor disconnected"** is set to **"warning"**, When the fuel Level sensor is detected to be disconnected, Then start warning delay and the duration (Normal alarm delay) have not returned to normal, the warning of fuel Level sensor disconnected warning is reported. **"ALARM"** lights will light up, Generators will not stop, displays **"FL sensor open"** on the current fault screen.

#### Over battery voltage warning

When the controller detects that the battery voltage is over than the **"Over battery voltage warning"**, Then start warning delay and the duration (Normal alarm delay) have not returned to normal, the warning of over battery voltage warning is reported. **"ALARM"** lights will light up, Generators will not stop, displays **"Over BATT volt"** on the current fault screen.

#### Under battery voltage warning

When the controller detects that the battery voltage is lower than the **"Under battery voltage warning"**, Then start warning delay and the duration (Normal alarm delay) have not returned to normal, the warning of Under battery voltage warning is reported. **"ALARM"** lights will light up, Generators will not stop, displays **"Under BATT volt"** on the current fault screen.

#### Maintenance expiration warning

When the controller parameter **"Maintenance expire"** is set to **"warning"**, when the primary countdown to maintenance is detected as **"0"** or primary maintenance date less than current date, then start warning delay and the duration (normal alarm delay), the warning of maintenance expiration is reported. **"ALARM"** lights will light up, without stopping the engine, and displays **"Maintain end"** on the LCD screen.

#### ◆ Shutdown Alarms



Warning: After the Shutdown Alarm occurs, the system will be locked immediately and the generator set will be stopped. Only after troubleshooting, press



key to clear the alarm, can it be re-operated.



Notes: When the shutdown alarm failure occurs, the Alarm light **"ALARM"** flashing and the generator unit automatically stops.

#### Over Speed Alarm

When the controller detects that the engine speed is higher than **"Over speed alarm"**, Then start alarm delay and the duration have not lower than **"Over speed revert"**, the alarm of over speed is reported. Alarm light **"ALARM"** flashing, Generator stops running, and displays **" Over speed "** on the current fault screen.

### Under Speed Alarm

When the controller detects that the engine speed is under than "**Under speed alarm**", Then start alarm delay and the duration have not higher than "**Under speed revert**", the alarm of under speed is reported. Alarm light "**ALARM**" flashing, Generator stops running, and displays "**Under speed**" on the current fault screen.

### Speed signal lost alarm

When the controller parameter "**Action if RPM lost**" is set to "**alarm**", the detected speed value is 0, Then start alarm delay and the duration (Normal alarm delay) have not returned to normal, the alarm of speed signal lost warning is reported. Alarm light "**ALARM**" flashing, Generator stops running, displays "**Lose speed**" on the current fault screen.

### Over frequency alarm

When the controller detects that the generator frequency is higher than "**Over frequency alarm**", Then start alarm delay and the duration have not returned to normal, the alarm of over frequency is reported. Alarm light "**ALARM**" flashing, Generator stops running, displays "**Over frequency**" on the current fault screen.

### Under frequency alarm

When the controller detects that the generator frequency is lower than "**Under frequency alarm**", Then start alarm delay and the duration have not returned to normal, the alarm of under frequency is reported. Alarm light "**ALARM**" flashing, Generator stops running, displays "**Under frequency**" on the current fault screen

### Over voltage alarm

When the controller detects that the generator voltage is higher than "**Over voltage alarm**", Then start alarm delay and the duration have not returned to normal, the alarm of over voltage is reported. Alarm light "**ALARM**" flashing, Generator stops running, displays "**Over voltage**" on the current fault screen.

### Under voltage alarm

When the controller detects that the generator voltage is lower than "**Under voltage alarm**", Then start alarm delay and the duration have not returned to normal, the alarm of under voltage is reported. Alarm light "**ALARM**" flashing, Generator stops running, displays "**Under voltage**" on the current fault screen.

### Over current alarm

When the controller parameter "Action in case of over current" is set to "**Alarm**", the controller detects generator phase current is higher than "**Phase current over-load alarm**", Then start alarm delay and the duration have not returned to normal, the alarm of over current is reported. Alarm light "**ALARM**" flashing, Generator stops running, displays "**Over current**" on the current fault screen.

### Non-balance current ratio alarm

When the controller parameter "**Non-balance current Action**" is set to "**Alarm**", the controller is 2 phase 3 wire or 3 phase 4 wire, the controller detects that the unbalance degree of the three-phase or two-phase current of the generator is higher than the "**Non-balance current ratio alarm**". Then start alarm delay and the duration have not returned to normal, the alarm of Non-balance current ratio is reported. Alarm light "**ALARM**" flashing, Generator stops running, displays "**Unbalance of AMP**" on the current fault screen.

### Over power alarm

When the controller parameter "**Over power Action**" is set to "**Alarm**", the controller detects that the generator power is higher than "**Over total power alarm**", Then start alarm delay and the duration have not returned to normal, the alarm of over power is reported. Alarm light "**ALARM**" flashing, Generator stops running, displays "**Over power**" on the current fault screen.

### Low Oil Pressure Sensor Alarm

When the controller detects that the engine Oil Pressure is lower than "**Low oil pressure alarm**", Then start alarm delay and the duration (Normal alarm delay) have not returned to normal, the alarm of low Oil Pressure is reported. Alarm light "**ALARM**" flashing, Generator stops running, and displays "**Low OP sensor**" on the current fault screen.

### High coolant temperature sensor alarm

When the controller detects that the coolant temperature value is higher than the "**High coolant temperature alarm**", Then start alarm delay and the duration (Normal alarm delay) have not returned to normal, the alarm of High coolant temperature alarm is reported. Alarm light "**ALARM**" flashing, Generator stops running, and displays "**High WT sensor**" on the current fault screen.

### High oil temperature sensor alarm

When the controller detects that the oil temperature value is higher than the "**High oil temperature alarm**", Then start alarm delay and the duration (Normal alarm delay) have not returned to normal, the alarm of High oil temperature alarm is reported. Alarm light "**ALARM**" flashing, Generator stops running, and displays "**High OT sensor**" on the current fault screen.

### High cylinder temperature sensor alarm

When the controller detects that the cylinder temperature value is higher than the "**High cylinder temperature alarm**", Then start alarm delay and the duration (Normal alarm delay) have not returned to normal, the alarm of High cylinder temperature alarm is reported. Alarm light "**ALARM**" flashing, Generator stops running, and displays "**High CT sensor**" on the current fault screen.

### Low fuel level sensor alarm

When the controller detects that the fuel level value is lower than the "**Low fuel level alarm**", Then start alarm delay and the duration (Normal alarm delay) have not returned to normal, the alarm of Low fuel level alarm is reported. Alarm light "**ALARM**" flashing, Generator stops running, and displays "**Low fuel level-A**" on the current fault screen.

### Oil pressure sensor disconnected alarm

When the controller parameter "**Action if low oil pressure sensor disconnected**" is set to "**alarm**", When the oil pressure sensor is detected to be disconnected, Then start alarm delay and the duration (Normal alarm delay) have not returned to normal, the alarm of Oil pressure sensor disconnected alarm is reported. Alarm light "**ALARM**" flashing, Generator stops running, displays "**OP sensor open**" on the current fault screen.

### Coolant temperature sensor disconnected alarm

When the controller parameter "**Action if water temperature sensor disconnected**" is set to "**alarm**", When the coolant temperature sensor is detected to be disconnected, Then start alarm delay and the duration (Normal alarm delay) have not returned to normal, the alarm of coolant temperature sensor disconnected alarm is reported. Alarm light "**ALARM**" flashing, Generator stops running, displays "**WT sensor open**" on the current fault screen.

### Oil temperature sensor disconnected alarm

When the controller parameter "**Action if oil temperature sensor disconnected**" is set to "**alarm**", When the oil temperature sensor is detected to be disconnected, Then start alarm delay and the duration (Normal alarm delay) have not returned to normal, the alarm of oil temperature sensor disconnected alarm is reported. Alarm light "**ALARM**" flashing, Generator stops running, displays "**OT sensor open**" on the current fault screen.

### Cylinder temperature sensor disconnected alarm

When the controller parameter "**Action if cylinder temperature sensor disconnected**" is set to "**alarm**", When the cylinder temperature sensor is detected to be disconnected, Then start alarm delay and the duration (Normal alarm delay) have not returned to normal, the alarm of cylinder temperature sensor disconnected alarm is reported. Alarm light "**ALARM**" flashing, Generator stops running, displays "**CT sensor open**" on the current fault screen.

### Fuel Level sensor disconnected alarm

When the controller parameter "**Action if fuel Level sensor disconnected**" is set to "**alarm**", When the fuel Level sensor is detected to be disconnected, Then start alarm delay and the duration (Normal alarm delay) have not returned to normal, the alarm of fuel Level sensor disconnected alarm is reported. Alarm light "**ALARM**" flashing, Generator stops running, displays "**FL sensor open**" on the current fault screen.

### Low oil pressure switch alarm

When the controller detects that the AUX. Input port "**Low oil pressure alarm input**" switch is active. Start low oil pressure switch alarm delay, for a period of time "Normal alarm delay" AUX. Input port "**low oil pressure alarm input**" switch is valid. Then the alarm, Alarm light "**ALARM**" flashing, stop the unit operation, and display "**Low OP switch**" on the current fault screen.

### High coolant temperature switch alarm

When the controller detects that the AUX. Input port "**High coolant temperature alarm switch**" switch is active. Start low oil pressure switch alarm delay, for a period of time "Normal alarm delay" AUX. Input port "**High coolant temperature alarm switch**" is valid. Alarm light "**ALARM**" flashing, stop the unit operation, and display "**High WT switch**" on the current fault screen.

### High oil temperature switch alarm

When the controller detects that the AUX. Input port "**High oil temperature alarm switch**" switch is active. Start low oil pressure switch alarm delay, for a period of time "Normal alarm delay" AUX. Input port "**High oil temperature alarm switch**" is

valid. Alarm light **"ALARM"** flashing, stop the unit operation, and display **"High OT switch"** on the current fault screen.

#### **High cylinder temperature switch alarm**

When the controller detects that the AUX. INPUT port **"High cylinder temperature alarm switch"** switch is active. Start low oil pressure switch alarm delay, for a period of time "Normal alarm delay" AUX. INPUT port **"High cylinder temperature alarm switch"** is valid. Alarm light **"ALARM"** flashing, stop the unit operation, and display **"High CT switch"** on the current fault screen.

#### **Low fuel level switch alarm**

When the controller detects that the AUX. Input **"Low fuel level alarm input"** switch is active, it starts alarm delay and lasts for Normal alarm delay. When the **"Low fuel level alarm input"** switch is enabled, the engine low fuel level switch alarm is reported. Alarm light **"ALARM"** flashing, Generator stops running, and displays **"Low fuel level-D"** on the current fault screen.

#### **Low coolant level switch alarm**

When the controller detects that the AUX. Input **"Low water level alarm"** switch is active, it starts alarm delay and lasts for Normal alarm delay. When the **"Low water level alarm"** switch is enabled, the engine low coolant level switch alarm is reported. Alarm light **"ALARM"** flashing, Generator stops running, displays **"Low water level"** on the current fault screen.

#### **Louver opening exception alarm**

When the controller detects that the AUX. Input **"Louver status input"** switch is active, it starts alarm delay and lasts for Normal alarm delay. When the **"Louver status input"** switch is enabled, the Louver status input alarm is reported. Alarm light **"ALARM"** flashing, Generator stops running, displays **"Louver abnormal"** on the

#### **External instant trip and stop alarm**

When the controller detects that the **"External instant trip and stop alarm input"** switch of the AUX. Input port is valid, the external instant trip is started and the shutdown alarm delay is delayed for a period of time **"Normal alarm delay"** AUX. Input port **"External instant trip and stop alarm input"** switch When it is valid, it will alarm, the public alarm light Alarm light **"ALARM"** flashing, Generator stops running, and display **"trip and stop alarm"** on the current fault screen.

#### **Maintenance expiration alarm**

When the controller parameter **"Maintenance expire"** is set to **"alarm"**, when the countdown to maintenance is detected as **"0"** or maintenance date less than current date, then start alarm delay and the duration (normal alarm delay), the alarm of maintenance expiration is reported. Alarm light **"ALARM"** flashing, without stopping the engine, and displays **"Maintain end"** on the LCD screen.

#### **Fail to Start**

If the number of cranks exceeds the predetermined number of cranks, the failure of start-up will be reported if the start-up of the generating unit is still unsuccessful. Alarm light **"ALARM"** flashing, without stopping the engine, and displays **"Crank failure"** on the current fault screen.

### Emergency stop alarm

When the controller detects that the input voltage of PIN 3 is less than 2V, then start alarm delay and the duration (**0.5s**) have not returned to normal, the alarm of Emergency Stop is reported. Alarm light "**ALARM**" flashing, Generator stops running, and displays "**Emergency stop**" on the current fault screen.

### Stop failure with speed alarm

When the controller detects that the speed is not "0" after the execution of the shutdown, the alarm of stop failure is reported. Alarm light "**ALARM**" flashing and displays "**Stop fail-RPM**" on the current fault screen.

### Stop failure with frequency alarm

When the controller detects that the frequency is not "0" after the execution of the shutdown, the alarm of stop failure is reported. Alarm light "**ALARM**" flashing and displays "**Stop fail-Hz**" on the current fault screen.























### Stop failure with pressure alarm

When the controller detects that the Oil **Pressure** is not "0" after the execution of the shutdown, the alarm of stop failure is reported. Alarm light "**ALARM**" flashing and displays "**Stop fail-OP-A**" on the current fault screen.

## 11. Parameters setting

### ◆ Enter the edition page

Please set the parameters according to below steps:

- 1) In the stop mode, please  and  simultaneously, then loose  so that you can come to password interface, the default password is "**07623**".
- 2) Press  and add number 1, press  to reduce number 1, press  to turn the digit into right, press  to turn the digit into left, press  once done. Then system comes into menu after confirmation of password setting. The screen will display error if password is wrong. The correct password should be put after pressing any button.
- 3) Press  to turn the digit into upper position, press  to turn the digit into lower position, press  to get into parameters setting page.
- 4) Press  to shift up the parameters, press  to shift down the parameters, press  to get into parameter changing page.
- 5) Press  to add number 1, press  to reduce number 1, press  to turn the digit into right and press  to turn the digit into left, press  once done. If the parameters setting is in the valid setting range, then it can be saved, if not, it can't be saved.
- 6) Press  and  to save the parameters and exit from edition page.
- 7) Press  to revert back to last class if in any setting position.



Revert back to default: put password “97011” when coming into parameters setting, then all the parameters can be set as defaults.

Note: the data can't be saved if the user didn't press OK and STOP to confirm the setting.

◆ Parameter list.

1) Basic setting

No	Parameter	Range(default)	Notes
0	Language	0-English 1-简体中文 2-繁体中文 3-Русский 4-Espanol 5-Türk dili 6-Français 7-Românesc 8-Polski 9-Português 10-Deutsch 11-한국어 12-Tiếng Việt 13-العربية 14-Bahasa Indonesia; 15-فارسی	Language option. Display language selection. 0: English, 1: Simplified Chinese, 2: Traditional Chinese, 3: Spanish, 4: Russian, 5: Turkish, 6: French, 7: Romanian, 8: Polish, 9: Portuguese, 10: German, 11: Korean, 12: Vietnamese, 13: Arabic, 14: Bahasa Indonesia, 15: Persian.
1	Gens poles	2/4/6/8(4)	When the flywheel teeth is set as 0, the RPM will be resulted by frequency. Pole 2: 50Hz---3000RPM. Pole 4: 50Hz---1500RPM. Pole 6: 50Hz---1000RPM. Pole 8: 50Hz---750RPM.
2	Gens AC system	Disable 1 phase 2 wire 2 phase 3 wire 3 phase 3 wire 3 phase 4 wire	Gens phases: No gens parameters can be displayed if setting as disable, which is applied to water pump genset.
3	CT rate	5-6000A/5A (500A/5A)	Used for setting genset CT primary current, secondary rated current 5A.
4	Rated frequency	40.0-80.0Hz(50.0Hz)	Calculate the alarm value.
5	Rated voltage	80-360V(230V)	Calculate the alarm value.
6	Rated current	5-6000A(500A)	Calculate the alarm value.
7	Rated total power	5-20000Kw (276Kw)	Set total power of generator to choose the meter range and calculate the average loading rate and alarm value.
8	Rated battery voltage	8.0-36.0V(24.0V)	Calculate the alarm value. One battery gens should be set as 12V, two batteries gens should be set as 24V.
9	Rated RPM	500-4500RPM(1500)	Calculate the alarm value.
10	Flywheel teeth	0-300(0)	If the setting is 0, (RPM sensor Disabled), then RPM is resulted by Hz.

11	Oil pressure sensor	0: User-defined <b>1: VDO 0-10Bar</b> 2: MEBAY-003B 3: SGH 4: SGD 5: SGX 6: CURTIS 7: DATCON 10Bar 8: VOLVO-EC 9: 3015237 10Bar 10: SUZUKI	Choose the usual oil pressure sensor, if the sensor users choose is not the 10 types, it can be User-defined.
12	Coolant temperature sensor	0: User-defined <b>1: VDO 40-120 °C</b> 2: MEBAY-001B 3: SGH 4: SGD 5: SGX 6: CURTIS 7: DATCON 8: VOLVO-EC 9: 3015238 10: PT100 11: MEBAY-Mier 12: YD custom 13: ECU-Q7 14: 465 15: SUZUKI 16: EQ465i	Choose the usual water temperature sensor, if the sensor users choose is not the 15 types, it can be User-defined.
13	Oil temperature sensor	0: User-defined <b>1: VDO 40-120 °C</b> 2: MEBAY-001B 3: SGH 4: SGD 5: SGX 6: CURTIS 7: DATCON 8: VOLVO-EC 9: 3015238 10: PT100 11: MEBAY-Mier	Choose the usual oil temperature sensor, if the sensor users choose is not the 11 types, it can be User-defined.
14	Cylinder temperature sensor	0: User-defined 1: MEBAY-Mier <b>2: PT100</b> 3-15: Reserved	If the sensor users choose is not the 2 types, it can be User-defined.
15	Fuel level sensor	0: User-defined 1: SGH(0-200Ω) 2: SGD(0-200Ω) 3: MEBAY150(0-100Ω) 4: ECU-Q7(100-0Ω) <b>5: ZP61-10(100-33Ω)</b>	If the sensor users choose is not the 24 types, it can be User-defined.

		6: VDO ohm range(10-180Ω) 7: VDO TUBE TYPE(90-0Ω) 8: US ohm range(240-33Ω) 9: GM ohm range(0-90Ω) 10: GM ohm range(0-30Ω) 11: Ford(73-10Ω) 12: YD-001(10-180Ω) 13: 0-107Ω 14: 107-0Ω 15: 0-180Ω 16: 180-0Ω 17: 180-10Ω 18: 120-10Ω 19: 10-120Ω 20: 33-100Ω 21: 0-200Ω 22: 200-0Ω 23: 0-190Ω 24: 190-0Ω	
16	Action if oil pressure sensor disconnected	Disable <b>Warning</b> Alarm and stop	Action if oil pressure sensor disconnected.
17	Action if water temperature sensor disconnected	Disable <b>Warning</b> Alarm and stop	Action if Water temperature sensor disconnected.
18	Action if oil temperature sensor disconnected	Disable <b>Warning</b> Alarm and stop	Action if oil temperature sensor disconnected.
19	Action if cylinder temperature sensor disconnected	Disable <b>Warning</b> Alarm and stop	Action if cylinder temperature sensor disconnected.
20	Action if fuel level sensor disconnected	Disable <b>Warning</b> Alarm and stop	Action if Fuel level sensor disconnected.
21	Pressure /Temperature unit	°C/KPA <b>°C/BAR</b> °C/PSI F/KPA F/BAR F/PSI	Unit display.

## 2)Basic setting 2

No	Parameter	Range(defaults)	Notes
1	Primary Modes	<b>STOP</b> Manual Auto	The primary modes on power, easy for user operation. Note: auto record function can not record the

		Auto save	mode with load.
2	Manual crank times	1-30 ( <b>1 time</b> )	Crank times under mode and test mode.
3	Auto start crank times	1-30 ( <b>3 times</b> )	Crank times under auto mode.
4	E.T.S. hold times	1-10( <b>2 times</b> )	The max E.T.S. hold on power shall be canceled once stop success under auto mode . the output interval time is " Fail to stop ".
5	Crank disconnect	RPM Hz Oil pressure(delay) <b>RPM/Frequency</b> RPM/Oil Pressure Frequency/Oil Pressure RPM/Frequency/Oil press.	1.If there is no oil pressure sensor, please dont choose it. 2.Oil pressure switch input is not the crank condition 3.Please check if the running status, stop condition are according with crank condition. 4.Means either of the conditions can be acceptable as crank condition. But all of them should be meet together to regard as stop condition.
6	Frequency disconnect	0-70%( <b>28%</b> )	Rated frequency multiplying by this value is regarded as crank success condition. When the gens frequency is over the condition value, then system regards it as crank success.
7	Oil pressure disconnect	0-400kpa( <b>200kpa</b> )	When the engine oil pressure is over the condition value, then system regards it as crank success, motor escaped.
8	RPM disconnect	0-200%( <b>24%</b> )	Rated RPM multiplying by this value is regarded as crank success condition. When the RPM is over the condition value, then system regards it as crank success, motor escaped.
9	OP pre-supply stop	50-600kpa( <b>200kpa</b> )	When the oil pressure is over the condition value, then pre-oil supply is stopped.
10	RPM-up stop	0-200%( <b>90%</b> )	Rated RPM multiplying by this value is regarded as speed-up stop value. When the RPM is over this value, then the RPM-Up procession is stopped in time.
11	Temperature-up stop	20-200℃ ( <b>68 ℃</b> )	When the water temperature is over the preset value, then temperature-up procession is stopped in time.
12	Voltage-up stop	0-200%( <b>85%</b> )	Rated voltage multiplying by this value is regarded as voltage-up stop value. When the voltage is over this value, then the voltage-Up procession is stopped in time.
13	Fan Control condition	<b>Water temperature</b> Oil temperature Cylinder temperature	Radiator Fan control output condition

14	Temperature for Fan open	20—200℃ ( <b>75 ℃</b> )	Used for controlling radiator: when the temperature reaches the set temperature, then the radiator is opened.
15	Temperature for Fan close	20—200℃ ( <b>60 ℃</b> )	Used for controlling radiator: when the temperature is lower than the set temperature, then the radiator is closed.
16	Maintenance countdown	0-5000h( <b>800h</b> )	When it is set as 5000, then this function is disabled.
17	User password	00000-65535( <b>07623</b> )	Change the password.
18	Maintenance expire	<b>Warning</b> /Alarm and stop	The action after the primary maintenance expired.
19	Maintenance date	<b>2000/01/01</b> -2099/12/31	When it is set as 2000/01/01, this function is disabled.
20	ATS in manual mode	<b>Disable</b> /Enable	When it is set to enabled, when the generator set meets the closing conditions, it will be loaded automatically.
21	Oil pressure delay	0-20.0s( <b>0.0s</b> )	When the crank condition contains oil pressure, if the oil pressure is higher than the preset value and continue for few seconds, then it is regarded as crank success.
22	Maintenance expiry reset password	0-65535 ( <b>06869</b> )	When the maintenance countdown time arrives, enter the password to reset the maintenance countdown time, this password cannot be the same as the parameter setting password.

### 3)Delay time setting

No	Parameter	Range(defaults)	Notes
1	Start delay	0-65000s( <b>5.0s</b> )	The time during the genset starts after the mains failure or remote signal is valid.
2	Preheat time	0-6500.0s( <b>0.0s</b> )	The time needed to be preheat before the starter on power.
3	Longest pre-oil supply	0-180.0s( <b>0.0s</b> )	Under pre-oil supply, if the oil pressure is higher than setting value, then pre-oil supply stopped.
4	Cranking time	3.0-60.0s( <b>8.0s</b> )	The time when the starter is on power.
5	Crank rest time	3.0-60.0s( <b>10.0s</b> )	If crank failure, the waiting time before the second test time.
6	Safety delay	1.0-60.0s( <b>8.0s</b> )	Low oil pressure, high water temperature, under speed, under frequency, under voltage, charge failure are all invalid during this time except for emergency stop ,over speed, over freq.
7	Start idle time	0-3600.0s( <b>5.0s</b> )	Idle running time when crank successfully.
8	Longest RPM-up time	0-3600.0s ( <b>120.0s</b> )	The longest speed-up time,during which time the system will exit once speed increased successfully .
9	Longest Temp.-up time	0-3600.0s( <b>0.0s</b> )	The longest warming-up time,during which time the system will exit once temperature increased successfully .

10	Longest Volt.-up time	0-3600.0s <b>(120.0s)</b>	The longest voltage-up time,during which time the system will exit once voltage increased successfully .
11	Warming-up time	0-3600.0s <b>(10.0s)</b>	The time needed for loading.
12	Back to Mains time	0-3600.0s <b>(10.0s)</b>	To avoid the switch actions if the mains unstable.If the remote start signal is invalid (DC42D will check if the mains normal), genset will not switch immediately, after the delay time, it will transfer to mains. during the delay, if the remote start signal is valid, then genset will come into rated running.
13	Back to Gens time	0-3600.0s <b>(5.0s)</b>	There shall be loading delay from Mains to Gens if the remote start signal valid or Mains abnormal under Cooling time.
14	Cooling time	0-3600.0s <b>(30.0s)</b>	After unloading, the time of cooling down by radiator before stop. During the delay, if the remote start signal is valid, then genset will come into rated running.
15	Stop idle time	0-3600.0s <b>(5.0s)</b>	Idle-speed running time.
16	E.T.S. hold time	0-600.0s <b>(10.0s)</b>	Stop solenoid on power time.
17	Fail to stop	5-180.0s <b>(30.0s)</b>	If the RPM is 0 during the stop failure time, then the stop failure time is no needed.
18	Emergency delay	0-10.0s <b>(1.5s)</b>	Over frequency alarm delay.
19	Normal alarm delay	2.0-20.0s <b>(5.0s)</b>	The alarm delay except for emergency stop and over frequency.
20	Over current 【inverse time】	0.1-36.0 <b>(36.0)</b>	This option will not take effect until the [Over phase current delay] is set to 0. The overcurrent delay is inverse time, and the formula is $T=t/((IA/IT) - 1)^2$ .
21	Choke close delay	0-200.0s <b>(3.0s)</b>	Choke close delay.
22	Speed pulse delay	0.1-60.0s <b>(60.0s)</b>	The speed pulse output interval time. 60.0 constant output.
23	Over phase current delay	0-3600.0s <b>(30s)</b>	When this parameter is set to 0, the over current delay is the inverse time; if not, the over current delay is the time set for this parameter.
24	Fuel output delay	1.0-60.0s <b>(2.0s)</b>	The output time of fuel valve relay before crank.
25	Closing output time	1.0-10.0s <b>(5.0s)</b>	when it is 10s, it is regarded as continuous output.
26	Opening output time	0.0-10.0s <b>(0.0s)</b>	when it is 0s, it is regarded as disable unload output.
27	Mains closing delay	0-3600.0s <b>(1.0s)</b>	The delay time before the mains is closed.
28	Gens closing delay	0-3600.0s <b>(3.0s)</b>	The delay time before the generation is closed.
29	Over current Alarm Delay	0-3600.0s <b>(30s)</b>	When this parameter is set to 0, the over power delay is the inverse time; if not, the over current delay is the time set for this parameter.
30	Over current 【inverse time】	0.1-36.0 <b>(36.0)</b>	This option will not take effect until the [Over total power delay] is set to 0. The over power delay is inverse time, and the formula is $T=t/((IA/IT) - 1)^2$ .

#### 4) Engine Alarm setting

No	Parameter	Range (defaults)	Notes
1	Over speed alarm	0-200% <b>(114%)</b>	Rated RPM multiplying by this value is regarded as over speed alarm value. When the RPM is higher than the alarm value and comes into over speed delay but still higher (emergency faults delay), then over speed alarms. If the value is set as 200, then the over speed alarm is disabled.
2	Under speed alarm	0-200% <b>(80%)</b>	Rated RPM multiplying by this value is regarded as under speed alarm value. When the RPM is lower than the alarm value and comes into under speed delay but still lower (normal faults delay), then under speed alarms. If the value is set as 0, then the under speed alarm is disabled.
3	Low oil pressure alarm	0-999kpa <b>(103kpa)</b>	When the oil pressure is lower than the alarm value and comes into low oil pressure delay but still lower (normal faults delay), then low oil pressure alarms. If the value is set as 0, then the under speed alarm is disabled.
4	High water temperature alarm	20-200°C <b>(98 °C)</b>	When the water temperature is higher than the alarm value and comes into high temperature delay but still higher (normal faults delay), then high temperature alarms. If the value is set as 200, then the high temperature alarm is disabled.
5	High oil temperature alarm	20-200°C <b>(100 °C)</b>	When the temperature is higher than the alarm value and comes into high temperature delay but still higher (normal faults delay), then high temperature alarms. If the value is set as 200, then the high temperature alarm is disabled.
6	High cylinder temperature alarm	20-200°C <b>(150 °C)</b>	When the temperature is higher than the alarm value and comes into high temperature delay but still higher (normal faults delay), then high temperature alarms. If the value is set as 200, then the high temperature alarm is disabled.
7	Low fuel level warning	0-100% <b>(20%)</b>	When the fuel level is lower than the value and comes into low fuel level warning delay but still lower (normal warning delay), then low fuel level warns. If it is higher than the value then warning clears. If the value is set as 0, then the low fuel level warning is disabled.
8	Low fuel level alarm	0-100% <b>(0%)</b>	When the fuel level is lower than the alarm value and comes into low fuel level delay but still lower (normal faults delay), then low fuel level alarms. If the value is set as 0, then the under speed alarm is disabled.
9	Over battery voltage warning	0-200% <b>(135%)</b>	Rated battery voltage multiplying by this value is regarded as over battery voltage warning value. When the battery input is higher than the warning value and comes into over battery voltage delay but still higher (normal faults delay), then over battery voltage warns. If the value is set as 200, then the over battery voltage is disabled.
10	Under battery voltage warning	0-200% <b>(67%)</b>	Rated battery voltage multiplying by this value is regarded as under battery voltage warn value. When the battery input is lower than the warning value and comes into under battery voltage delay but still lower (normal faults

		delay), then under battery voltage warns. if the value is set as 0, then the under battery voltage is disabled.
--	--	---

### 5) Generator alarm setting

No	Parameter	Range (default)	Notes
1	Over freq alarm	0-200% <b>(114%)</b>	Rated frequency multiplying by this value is regarded as under over frequency alarm value. When the Freq is higher than the value and comes into over freq delay but still higher (emergency faults delay), then over frequency alarms.If the value is set as 200, then the alarm is disabled.
2	Under freq alarm	0-200% <b>(80%)</b>	Rated frequency multiplying by this value is regarded as under frequency alarm value. When the Freq is lower than the value and comes into under freq delay but still lower (normal faults delay), then under frequency alarms.If the value is set as 0, then the alarm is disabled.
3	Over voltage warning	0-200% <b>(120%)</b>	Rated voltage multiplying by this value is regarded as over voltage alarm value. When the voltage is higher than the value and comes into over voltage delay but still higher (normal faults delay), then over voltage alarms.If the value is set as 200, then the alarm is disabled.
4	Under voltage alarm	0-200% <b>(80%)</b>	Rated voltage multiplying by this value is regarded as under voltage alarm value. When the voltage is lower than the value and comes into under voltage delay but still lower (normal faults delay), then under voltage alarms.If the value is set as 0, then the alarm is disabled.
5	Phase current over-load alarm	0-200% <b>(100%)</b>	Rated current multiplying by this value is regarded as over current alarm value. When the current is higher than the value and comes into over current delay but still higher (over current faults delay), then over current alarms.If the value is set as 200, then the alarm is disabled.
6	Non-balance current ratio warning	10-100% <b>(100%)</b>	It is valid for 2P3W or 3P4W.When the non-balance current ratio is higher than the value and comes into delay but still higher(normal warn delay), then non-balance current ratio warns.If the value is set as 100, then the warning is disabled.
7	Over total power alarm	0-200% <b>(100%)</b>	Rated power multiplying by this value is regarded as over power alarm value. When the loading power is higher than the value and comes into delay but still higher (power faults delay), then over power alarms..If the value is set as 200, then the alarm is disabled.

### 6) AUX. Input/Output setting

No	Parameters	Range(defaults)	Notes
1	AUX.OUTPUT 1	0-30( <b>2. Public alarm</b> )	Set the default value (please refer to the AUX. Output function table)
2	AUX.OUTPUT 2	0-30( <b>12. E.S.T. hold</b> )	
3	AUX.OUTPUT 3	0-30( <b>10.Gens load</b> )	
4	AUX.OUTPUT 4	0-30( <b>9.Idle speed control</b> )	
			<b>Set the state when the</b>



			<b>AUX. output is valid.</b>
<b>AUX. Output function table</b>			
<p><b>0. Disable.</b></p> <p><b>1. Public warning output:</b> when there is any warning output.</p> <p><b>2. Public alarm output:</b> when there is any alarm output, alarm locks till revert back.</p> <p><b>3. Shades control:</b> there is output once genset starts and stop till stable.</p> <p><b>4. Preheat mode 1:</b> preheat before start.</p> <p><b>5. Pre-oil supply control:</b> Under pre-oil supply, if the oil pressure is higher than setting value or pre-oil supply time ends, then pre-oil supply stopped.</p> <p><b>6. Choke control:</b> choke will be started after crank success and off after delay.</p> <p><b>7. Fuel output:</b> output once gens starts and off till stable.</p> <p><b>8. Crank output:</b> output once cranking.</p> <p><b>9. Idle speed control:</b> used for speed controller, there is no output under idle but output under high speed.</p> <p><b>10. Gens load:</b> there is continuous output once the conditions can be meet, which can control the switch with load.</p> <p><b>11. Fan Control:</b> used to control radiator electrical fan. there is output when the preset temperature is higher than "<b>Temperature for Fan open</b>" and no output when the preset temperature is lower than "<b>Temperature for Fan close</b>".</p> <p><b>12. E.S.T. hold:</b> shutdown output, it is used for gens with stop solenoid. when the setting value of shutdown delay is over, then it is off.</p> <p><b>13. System in stop:</b> there is output under stop mode.</p> <p><b>14. System in manual:</b> there is output under manual mode.</p> <p><b>15. System in auto:</b> there is output under auto mode.</p> <p><b>16. Mains load:</b> continuous or pulse type according to time setting. (Only for DC42D MK4)</p> <p><b>17. Working plan running output:</b> when the working plan is started, there is output in running status if the genset meets conditions, if not, there is no output.</p> <p><b>18. Speed-up control:</b> there is output when coming into high speed up, which time is RPM up delay.</p> <p><b>19. Speed-down control:</b> the output time is shutdown idle delay during shutdown idle or shutdown on power procession.</p> <p><b>20. High speed control:</b> output after the idle delay is completed, and disconnected after high-speed heat dissipation.</p> <p><b>21. Rated running:</b> there is output under rated running.</p> <p><b>22. Unload control:</b> Public unload function, mains unload and genset unload will output.</p> <p><b>23. Gens open:</b> continuous or pulse type according to time setting.</p> <p><b>24. Mains open:</b> continuous or pulse type according to time setting. (Only for DC42D MK4).</p> <p><b>25. Excitation output:</b> there is output during cranking procession and there is 2s output if there is no frequency under high speed status.</p> <p><b>26. Preheat mode 2:</b> preheat before crank success.</p> <p><b>27. Preheat mode 3:</b> preheat after safety delay.</p> <p><b>28. Preheat mode 4:</b> preheat till temperature-up end.</p> <p><b>29. Preheat mode 5:</b> preheat till temperature-up end, but no preheat when motor starts.</p> <p><b>30. Reserved.</b></p>			
5	AUX. INPUT 1	0-20( <b>1. Remote start</b> )	Set the default value (please refer to the AUX. input function table)
6	Valid Type	<b>Normal close</b> Normal open	
7	AUX. INPUT 2	0-20( <b>2. Low oil pressure alarm</b> )	
8	Valid Type	<b>Normal close</b> Normal open	
9	AUX. INPUT 3	0-20( <b>3. High water temperature alarm</b> )	

10	Valid Type	<b>Normal close</b> Normal open	<b>Set the state when the AUX. input is valid.</b>
11	AUX. INPUT 4	0-20( <b>6. Low water level alarm</b> )	
12	Valid Type	<b>Normal close</b> Normal open	
13	AUX. INPUT 5	0-20( <b>7. Low fuel level warning</b> )	
14	Valid Type	<b>Normal close</b> Normal open	

**AUX. input function table**
**0. Disable.**

1. Remote start (on load).
2. Low oil pressure alarm switch.
3. High water temperature alarm switch.
4. High oil temperature alarm switch.
5. High cylinder temperature alarm switch.
6. Low water level alarm switch.
7. Low fuel level warning input.
8. Low fuel level alarm input.
9. Low oil pressure level warning input.
10. Low oil pressure level alarm input.
11. Shades status input.
12. External instant warning input.
13. External instant alarm input.
14. ---20 Reserved.

15	AUX. SENSOR 1	0-5( <b>1. Oil pressure sensor</b> )	<b>0. Disable.</b> <b>1. Oil pressure sensor input.</b> <b>2. Water temperature sensor input.</b> <b>3. Oil temperature sensor input.</b> <b>4. Cylinder temperature sensor input.</b> <b>5. Fuel level sensor input.</b>  <i>Note: every sensor input can be set as same function. (oil pressure, fuel level warns and alarm will be judged according to the lowest value. Water temperature, oil temperature, cylinder temperature, genset box temperature warns and alarm will be judged by the highest value. Either of the inputs for alarm opened.)</i>
16	AUX. SENSOR 2	0-5( <b>2. Water temperature sensor</b> )	
17	AUX. SENSOR 3	0-5( <b>0.Disable</b> )	

**7) Working maintenance plan setting**

No	Parameter	Range(defaults)	Notes
1	Working plan format	<b>Disable</b> Every month Every week	This mode must be under auto mode. Working plan is disabled once setting as disable. The working plan will be executed according the chosen date when setting as every month. The working plan will be executed according the chosen date when setting as every week.
2	Maintenance date per month	From 1 <sup>st</sup> to 31 <sup>st</sup> <b>Default: the first day</b>	The date chosen for every month.
3	Maintenance	Monday to Sunday	The date chosen for every week.

	date per week	<b>Default: Sunday</b>	
4	Maintenance with load or not	<b>Disabled</b> /with load	To choose if the genset starts with load or not.
5	Maintenance start time	00:00-23:59( <b>00:00</b> )	Maintenance start time setting.
6	Maintenance running time	1-120m( <b>5min</b> )	Maintenance running time setting.

### 8) Mains protection

No	Parameter	Range(defaults)	Notes
1	Phase	Disable 1 Phase 2 Wire 2 Phase 3 Wire 3 Phase 3 Wire <b>3 Phase 4 Wire</b>	Choose the input, there is no display if setting as disable.
2	Mains under volt	55-330V( <b>184V</b> )	When the mains voltage is lower than the "low voltage crank threshold" and comes into mains low voltage delay(normal failure delay) but still lower, then mains becomes invalid. If the voltage become higher than "low voltage revert threshold" during normal failure delay time, then it will not alarm.
3	Revert under volt	55-330V( <b>207V</b> )	
4	Mains over volt	55-330V( <b>276V</b> )	When the mains voltage is higher than the "high voltage crank threshold" and comes into mains high voltage delay(normal failure delay) but still higher, then mains becomes invalid. If the voltage become lower than "low voltage revert threshold" during normal failure delay time, then it will not alarm.
5	Revert over volt	55-330V( <b>253V</b> )	
6	Mains normal delay	0.0-3600.0S( <b>10.0S</b> )	The time from abnormal to normal, which is used for ATS transfer.
7	Mains abnormal delay	0.0-3600.0S( <b>5.0S</b> )	
8	Loss of Phase	<b>Loss of Phase 1</b> Loss of Phase 2 Loss of Phase 3	Set the phase loss condition to judge whether the mains is abnormal.

### 9) LCD setting

No	Parameter	Range(defaults)	Notes
1	Start screen display	0-20.0s( <b>5.0s</b> )	Start screen display time,0: No-display.
2	Saving mode	5.0-6000.0s ( <b>600.0s</b> )	LCD light will be closed automatically without any button pressed after delay.If setting as 200.0s, back light always lighted.
3	Homing display	5.0-600.0s ( <b>600.0s</b> )	The time when the page reverts back to the home page .If setting as 600.0s:disabled.
4	LOGO delay display under standby	5.0-6000.0 ( <b>6000.0s</b> )	Start screen will be opened without any button pressed after delay.If setting as 6000.0s: disabled.

**a) RS485 PORT**

No	Parameter	Range( <b>default</b> )	Notes
1	Controller address	1-255( <b>16</b> )	The IP built by controller and PC.
2	485 baud rate	0-4800 1-9600 <b>2-19200</b> 3-38400 4-57600 5-115200	RS485 communication baud rate selection.
3	485 CRC setting	<b>0-CRC L_H</b> 1-CRC H_L	Sequence selection of RS485 communication protocol CRC;

**b) Duty Plan setting**

No	Parameter	Range( <b>default</b> )	Notes
1	Working plan	<b>Disable</b> Enable 1: remote start Enable 2: running always	Working plan start condition.
2	Start time	00:00-23:59 ( <b>08:00</b> )	The start time allowed.
3	End time	00:00-23:59 ( <b>17:00</b> )	The end time allowed (the next day is valid).
4	Dates	1-31	Multiple choices according to the reality. The longest running time is 24 hours.

**c) Data/time setting**

No	Parameter	Range( <b>defaults</b> )	Notes
1	Date/Time	2000/01/01-2099/12/31	Internal calendar, please calibrate
2	Current time	00:00:00-23:59:59	regularly.

**d) Self-define curve**

NO	Parameter	Notes
1	Self-define oil pressure curve	<i>Sensor curve can be User-defined by panel buttons, resistance and according value should be input, MAX 15 groups, MIN 2 groups.</i> <b>Rule: resistance should be input from small to large.</b>
2	Self-define water temperature curve	
3	Self-define oil temperature curve	
4	Self-define cylinder temperature curve	
5	Self-define genset box temperature curve	
6	Self-define fuel level curve	

**e) ABF (Auto Battery Fail) function settings (only for DC42DR-ABF MK4)**

NO	Parameter	Range( <b>defaults</b> )	Notes
1	ABF function enable	<b>0: Disable</b> 1: Enable	After activating the ABF function, when in automatic mode, start the generator according to the starting conditions of the unit.
2	Unit startup conditions	0: Remote start valid 1: Low battery pack voltage 2: <b>Remote start is effective and battery pack voltage is low</b>	The conditions for starting the generator set after enabling the ABF function.
3	Unit shutdown conditions	0: Remote start invalid 1: Battery pack voltage is	The conditions for the generator set to stop after enabling the ABF function.

		normal 2: <b>Remote start invalid or battery pack voltage normal</b>	
4	Upper limit of battery pack voltage	0.0-100.0V( <b>58.0V</b> )	When the battery pack voltage is higher than this set value, it is determined that the battery pack is full.
5	Lower limit of battery pack voltage	0.0-100.0V( <b>45.0V</b> )	When the battery pack voltage is lower than this set value, it is determined that the battery pack voltage is low.
6	Minimum charging time of battery pack	0-600min( <b>30min</b> )	When the battery voltage is low, the shortest time for the generator to start and charge the battery pack.
7	Maximum charging time of battery pack	1-6000min( <b>720min</b> )	When the battery voltage is low, the maximum time for the generator to start and charge the battery pack.

## 12. Fault finding

Symptoms	Possible Solutions
Controller no response with power	Check DC voltage. Check DC fuse. Check if the terminal 1 and 2 is with battery voltage.
Genset shutdown	Check the water/cylinder temperature is too high or not. Check the genset AC voltage. Check DC fuse.
Genset Emergency Stop	Check the emergency stop button. Check that the voltage of the controller's 3 feet to the ground should be the battery voltage. Check the controller connection.
Low oil pressure alarm	Check oil pressure sensor and its wiring. Check the oil pressure sensor type and controller settings must be consistent. Check whether the low oil pressure sensor is normal.
High temperature alarm	Check temperature sensor and its wiring. Check the temperature sensor type and controller settings must be consistent. Check whether the temperature sensor is normal.
Shutdown Alarm in running	Check related switch and its connections according to the information on LCD. Check AUX. Inputs.
Fail to start	Check fuel return circuit and wiring. Check start battery. Consult engine manual.
Starter motor does not respond	Check the wiring to the starter. Check start battery.
Unit operation but ATS does not switch	Check the ATS. Check the cable between the controller and the ATS.
USB communication is	Check the USB connection.

abnormal	Check whether the USB port of the computer is normal. Check whether the USB driver is installed.
RS485 cannot communicate normally	Check the connection. Check if the communication ID number setting is correct. Check if the A and B lines of RS485 are reversed. Check if the RS485 communication line driver is installed or not. Check if the communication port of the PC is damaged. Add a 120 $\Omega$ resistor between the AB of the controller RS485.