

# DC7xD MK2 GENSET CONTROLLER USER MANUAL

## DC70D MK2



## DC72D MK2



## Software Version

No.	Version	Date	Note
1	V1.0	2020-07-09	Original release.
2	V1.1	2021-02-01	Name of unified input and output port.
3	V1.2	2021-09-22	Fix errors in the wiring diagram.
4	V1.3	2022-01-01	Add the option of whether to display ECU page. Add UI default color options; Switching value input adds the function of analog key and the remote start without load. Add the system log function, increase the number of alarm records.Add Emergency start function.
5	V1.4	2022-05-05	Add the function of selecting the effective mode of switching value. Add CAN bus speed control address setting. Add the baud rate setting of CAN bus. Add display language Turkish.
6	V1.5	2022-09-01	Added display language French. Add auxiliary machine mode. Add the function of voltage transformer. DC70D adds mains power detection function. Correct the AC voltage input range.
7	V1.6	2023-07-27	Added display language Korean(한국어)
8	V1.7	2023-12-18	Add features such as multiple display languages and AUX outputs.



Chongqing Mebay Technology Co.,Ltd

Add: No6-2,Building 4, Gangan Rd, Jiangbei District, Chongqing.



Tel: +86-23-6869 3061

Fax: +86-23-6765 8207

 Web: <http://www.mebay.cn>
<http://www.cqmb.cn>

 E\_mail: [sales@mebay.cn](mailto:sales@mebay.cn)

## Symbol Description

Symbol	Description
 Note	Remind operators to operate correctly, otherwise it may cause the equipment not to work correctly.
 Be care	It is indicated that potential hazards can damage equipment without proper precautions.
 Warning	It is indicated if appropriate preventive measures are not taken, potentially dangerous situations may result in death, serious personal injury or significant property losses.



### Warning

1. The installation of this equipment must be carried out by professionals.
2. When installing and operating the controller, please read the entire instruction manual first.
3. Any maintenance and commissioning of the equipment must be familiar with all the equipment.
4. t, safety standards and precautions in advance, otherwise it may cause personal injury or damage to related equipment.
5. The engine must have an overspeed protection device independent of the controller system to avoid casualties or other damage caused by engine out of control.
6. After the installation of the controller is completed, please verify that all protection functions are valid.



### Be Care

1. Please keep the good connection of the power supply of the controller. Do not share the connection lines of the positive and negative electrodes of the battery with the floating charger.
2. During the operation of the engine, do not disconnect the battery, otherwise it may cause damage to the controller.

## Catalogue

1. Summary .....	5
2. Main Features .....	5
3. Parameters Display .....	6
4. Protection .....	7
5. Parameters .....	8
6. Overall Dimension and Wiring Diagram .....	9
7. Installation instruction .....	16
8. Panel and display .....	17
9. Control and operation instruction .....	20
10. Warnings and Shutdown Alarms .....	23
11. Parameters setting .....	37
12. Fault finding .....	61

### Notes:

1. All rights reserved. No part of this duplication may be reproduced in any material form (including photocopying or storing in any medium by electronic means or others) without the written permission of the copyright holder.
2. MEBAY Technology reserves the rights to change the contents of this document without prior notice.

## 1. Summary

This series controller is specialized for Diesel / Gasoline / Gas Genset Start, Stop, Parameters monitoring, faults-checking as well as data setting.

4.3inch colorful LCD screen display with brand new UI design is adapted in this controller that the relative failures can be displayed directly. All the parameters can be displayed by simulated indicators and words. Besides, LCD screen can display various faults in the same time that the genset will be stopped once it can't work smoothly.

There are Chinese/English interface options, more language can be set according to user's request. All the parameters can be configured through the front face buttons or use programmable interface by RS485 or USB to adjust via PC. It can be widely applied for all kinds of auto control system of gensets.

## 2. Main Features

There are four Models under DC7xD MK2 series.

DC70D MK2: used for single machine automation. Start/Stop through remote start signal.

DC72D MK2: Based on DC70D MK2, it adds Mains monitoring and AMF (Mains/Generator automatic switching control), especially suitable for the automation system composed by mains and genset.

DC70DR MK2: Based on DC70D MK2, it adds RS485 port.

DC72DR MK2: Based on DC72D MK2, it adds RS485 port.

- ◆ 32bit high performance microcomputer.
- ◆ 4.3inch TFT colorful big screen LCD, Available in 5 languages, user's language set if necessary.
- ◆ Indicator and number display through UI surface.
- ◆ Acrylic material is adapted to protect the screen.
- ◆ Silicone panels;
- ◆ USB Port: parameters can be set even without power through USB port to monitor in real time.
- ◆ With RS485 communication port, can achieve "Three Remote" functions via MODBUS protocol.
- ◆ Standard CAN communication port, built-in J1939 protocol, has matched more than 30 kinds of engines;
- ◆ Various kinds of parameters display.
- ◆ Input/output function, status can be shown directly.
- ◆ More categories of surface setting.
- ◆ Real time clock inside: preset time operate and auto maintenance is available. Genset working plan can be set as per week or month.
- ◆ Three class protection countdown function, which can set the maintenance time or date.
- ◆ With event recording function, it can save 100 groups of alarm records, including relevant parameters of the unit in case of fault alarm; 5000 system logs can be saved to find the cause of failure;

- ◆ Totally 7 relay's output, among which 5 relay output can be self-configurable, each relay can be set as max 50 functions, besides, there are 4 groups as non-contact terminals.
- ◆ With 5 switches input, up to 40 functions optional;
- ◆ 4 sensor simulation input connectors, the oil pressure sensor is compatible with voltage signal input, and various display units can be configured.
- ◆ Battery charging control function, which can protect the battery according to battery voltage status.
- ◆ Sensor can be self-defined by front face button or PC software.
- ◆ Adapt to 3P4W, 1P2W, 2P3W (120V/240V, 50/60HZ)
- ◆ Various of crank conditions (RPM, Frequency, Oil Pressure) can be chosen.
- ◆ Control Protection: Auto Start/Stop of genset, load transfer (ATS control) and perfect failure display and protection.
- ◆ Standard water-proof rubber gasket. The waterproof can reach IP65.
- ◆ Module design: All the connections are adapted with European connectors so that installation, connection, repair and replacement can be more easily.

### 3. **Parameters Display**

- ◆ Engine RPM
- ◆ Engine oil pressure
- ◆ Engine water temperature
- ◆ Engine fuel temperature
- ◆ Engine cylinder temperature
- ◆ Engine Tank temperature
- ◆ Engine fuel level
- ◆ Engine battery voltage
- ◆ Charging voltage
- ◆ Mains Frequency (only for DC72D MK2)
- ◆ Mains phase voltage L-N (only for DC72D MK2)
- ◆ Mains phase voltage L-L (only for DC72D MK2)
- ◆ Generator 3 Phase voltage L-N
- ◆ Generator 3 Phase voltage L-L
- ◆ Generator 3 phase current A
- ◆ Generator Frequency Hz
- ◆ Generator Power Factor COS  $\varphi$
- ◆ Generator active power KW
- ◆ Generator apparent power KVA
- ◆ Generator reactive power KVar
- ◆ Real-time load rate %
- ◆ Current load rate %
- ◆ Average loading rate %
- ◆ Current consumption KWH
- ◆ Total consumption KWH
- ◆ Total Crank times

- ◆ Current running time
- ◆ Total running time
- ◆ Maintenance notice
- ◆ 5 switches input status display
- ◆ Output status display of 7 relays

#### 4. **Protection**

- ◆ Over speed
- ◆ Under speed
- ◆ Low oil pressure
- ◆ High water temperature
- ◆ High Oil temperature
- ◆ High Cylinder Temperature
- ◆ High Tank temperature
- ◆ Low fuel level
- ◆ Low oil level
- ◆ External instant unloading shutdown
- ◆ External emergency alarm
- ◆ RPM Lost
- ◆ Sensor Open
- ◆ Over Frequency
- ◆ Under Frequency
- ◆ Over voltage
- ◆ Under voltage
- ◆ Over current
- ◆ Non-balance of current
- ◆ Over power
- ◆ Gen load failure
- ◆ Gen unload failure
- ◆ Mains Load failure
- ◆ Mains unload failure
- ◆ Primary maintenance expire
- ◆ Secondary maintenance expire
- ◆ Third maintenance expire
- ◆ ECU alarm failure
- ◆ ECU communication Failure
- ◆ Low water level alarm
- ◆ Louver opening exception
- ◆ Emergency Stop
- ◆ Crank failure
- ◆ Stop Failure



## 5. Parameters

Options	Parameters
Working voltage	DC8V---36V Continuous
Power consumption	Standby: 24V: MAX 1W
	Working: 24V: MAX 5W
AC Voltage Input	1P2W 30VAC-360VAC (ph-N)
	2P3W 30VAC-360VAC (ph-N)
	3P4W 30VAC-360VAC (ph-N)
Rotate speed sensor Frequency	200-10000Hz
MAX Accumulating Time	99999.9Hours (Min Store time:6min)
Fuel Relay Output	Max 16Amp DC+VE Supply voltage
Start Relay Output	Max 16Amp DC+VE Supply voltage
AUX. OUTPUT 1	Max 5Amp DC+VE Supply voltage
AUX. OUTPUT 2	5AMP Non-contact normal open or normal close output
AUX. OUTPUT 3	5AMP Non-contact normal open output
AUX. OUTPUT 4	5AMP Non-contact normal open output
AUX. OUTPUT 5	5AMP Non-contact normal open or normal close output
Excitation output	DC+VE supply voltage
Switch value input	Available if connecting with Battery -
Working condition	-30-70℃
Storage condition	-40-85℃
Protection Level	IP65: when waterproof rubber gasket is added between controller and its panel
Insulation strength	Apply AC2.2kV voltage between high voltage terminal and low voltage terminal; The leakage current is not more than 3mA within 1min.
Overall dimension	210mm*160mm*50mm
Panel cutout	186mm*142mm
Weight	0.9Kg

**6. Overall Dimension and Wiring Diagram**

◆ **Overall Dimension:**

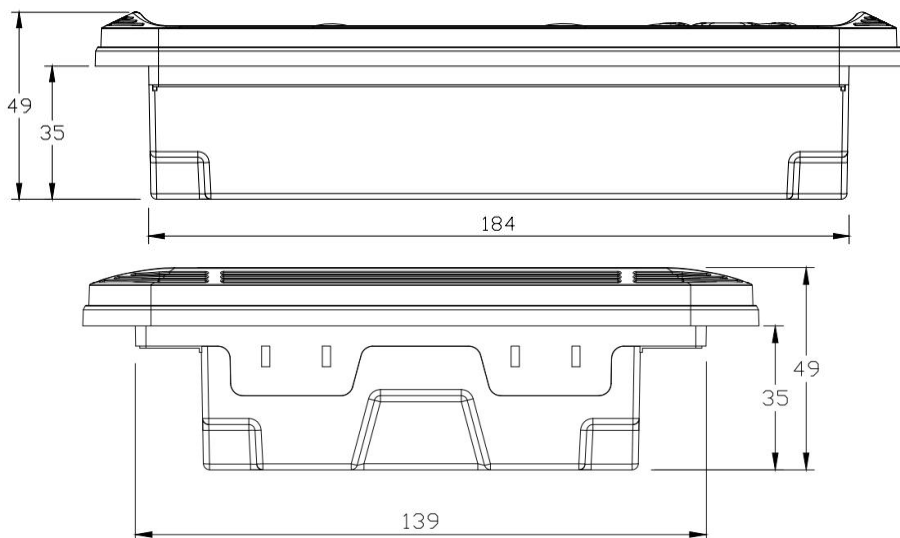

◆ **Descriptions of terminal connection**

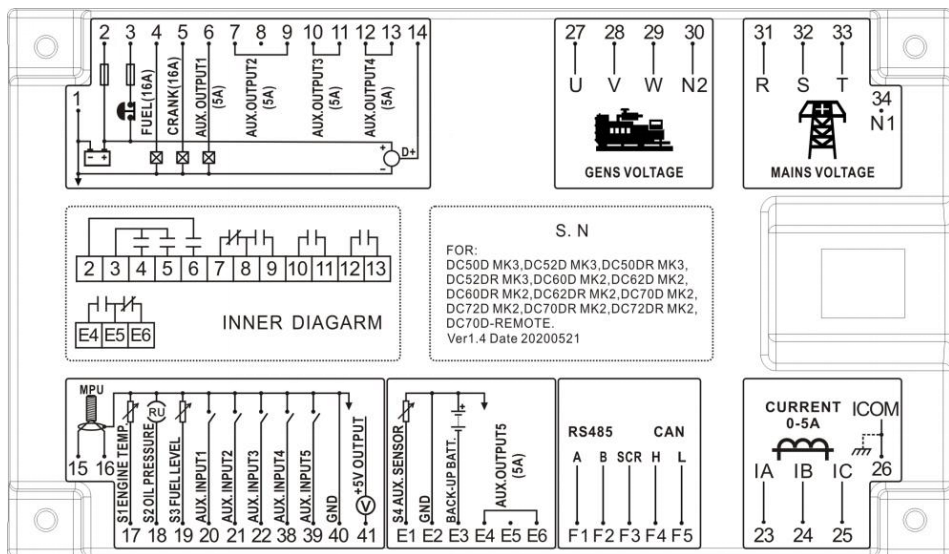

No.	Function	Description	Cable cross sectional area
1	Battery Negative Input B-	Controller power supply input B-.	2.5mm <sup>2</sup>
2	Battery Negative Input B+	Controller power supply input B+.	2.5mm <sup>2</sup>
3	Emergency Stop Input	B+ voltage input is active, and connected to emergency stop normal closed button.	2.5mm <sup>2</sup>
4	Fuel Output	+VE output, Max 16Amp	1.5mm <sup>2</sup>
5	Crank Output	+VE output, Max 16Amp.	1.5mm <sup>2</sup>
6	Aux. Output 1	+VE output, Max 5Amp.	1.5mm <sup>2</sup>
7	Aux. Output 2 Normal close	Passive Output, Max 5Amp.	1.5mm <sup>2</sup>
8	Aux. Output 2 Common		1.5mm <sup>2</sup>
9	Aux. Output 2 Normal open		1.5mm <sup>2</sup>
10	Aux. Output 3	Passive normally open output, Max 5Amp.	1.5mm <sup>2</sup>
11	Aux. Output 3		1.5mm <sup>2</sup>
12	Aux. Output 4	Passive normally open output, Max 5Amp.	1.5mm <sup>2</sup>
13	Aux. Output 4		1.5mm <sup>2</sup>
14	Charging excitation output	DC+VE supply voltage.	1.0mm <sup>2</sup>
15	Speed sensor -	Use a shielded wire to connect the speed sensor.	1.0mm <sup>2</sup>
16	Speed sensor +		1.0mm <sup>2</sup>
17	Temperature Sensor	Connect sensor input.	1.0mm <sup>2</sup>
18	Oil pressure sensor		1.0mm <sup>2</sup>
19	Fuel level sensor		1.0mm <sup>2</sup>

20	Aux. Input 1	The grounding is valid according to the function selection switch input.	1.0mm <sup>2</sup>
21	Aux. Input 2		1.0mm <sup>2</sup>
22	Aux. Input 3		1.0mm <sup>2</sup>
23	Load CT Secondary L1	Current Transformer Secondary Rated 5A.	1.5mm <sup>2</sup>
24	Load CT Secondary L2		1.5mm <sup>2</sup>
25	Load CT Secondary L3		1.5mm <sup>2</sup>
26	Load CT Secondary ICOM	Connect to the common.	1.5mm <sup>2</sup>
27	Generator Voltage U	Connected to the power generation output R phase.	1.0mm <sup>2</sup>
28	Generator Voltage V	Connected to the power generation output S phase.	1.0mm <sup>2</sup>
29	Generator Voltage W	Connected to the power generation output T phase.	1.0mm <sup>2</sup>
30	Generator Voltage N2	Connected to the power generation output N phase.	1.0mm <sup>2</sup>
31	Mains Voltage R	Connected to the mains U phase.	1.0mm <sup>2</sup>
32	Mains Voltage S	Connected to the mains V phase.	1.0mm <sup>2</sup>
33	Mains Voltage T	Connected to the mains W phase.	1.0mm <sup>2</sup>
34	Mains Voltage N1	Connected to the mains N phase.	1.0mm <sup>2</sup>
38	Aux. Input 4	The grounding is valid according to the function selection switch input.	1.0mm <sup>2</sup>
39	Aux. Input 5		1.0mm <sup>2</sup>
40	Sensor common GND	Connect the battery negative or outer.	1.0mm <sup>2</sup>
41	+5V Output	Connect the power supply of the oil pressure sensor with the output voltage signal, with a maximum of 50mA.	1.0mm <sup>2</sup>
E1	Oil Temperature Sensor	Connect sensor input.	1.0mm <sup>2</sup>
E2	GND	Connect the engine housing or battery negative.	1.5mm <sup>2</sup>
E3	Backup battery input	Negative voltage input	1.0mm <sup>2</sup>
E4	Aux. Output 5 Normal close	Passive Output, Max 5Amp.	1.5mm <sup>2</sup>
E5	Aux. Output 5 Common		1.5mm <sup>2</sup>
E6	Aux. Output 5 Normal open		1.5mm <sup>2</sup>
F1	RS485 B	A 120 Ω shielded wire and good grounding are recommended.	1.0mm <sup>2</sup>
F2	RS485 A		1.0mm <sup>2</sup>
F3	RS485 SCR		1.0mm <sup>2</sup>
F4	CAN H	Connected to the can communication port of ECU.	1.0mm <sup>2</sup>
F5	CAN L		1.0mm <sup>2</sup>

◆ **DC70D MK2 3-phase 4-wire Typical Wiring Diagram**

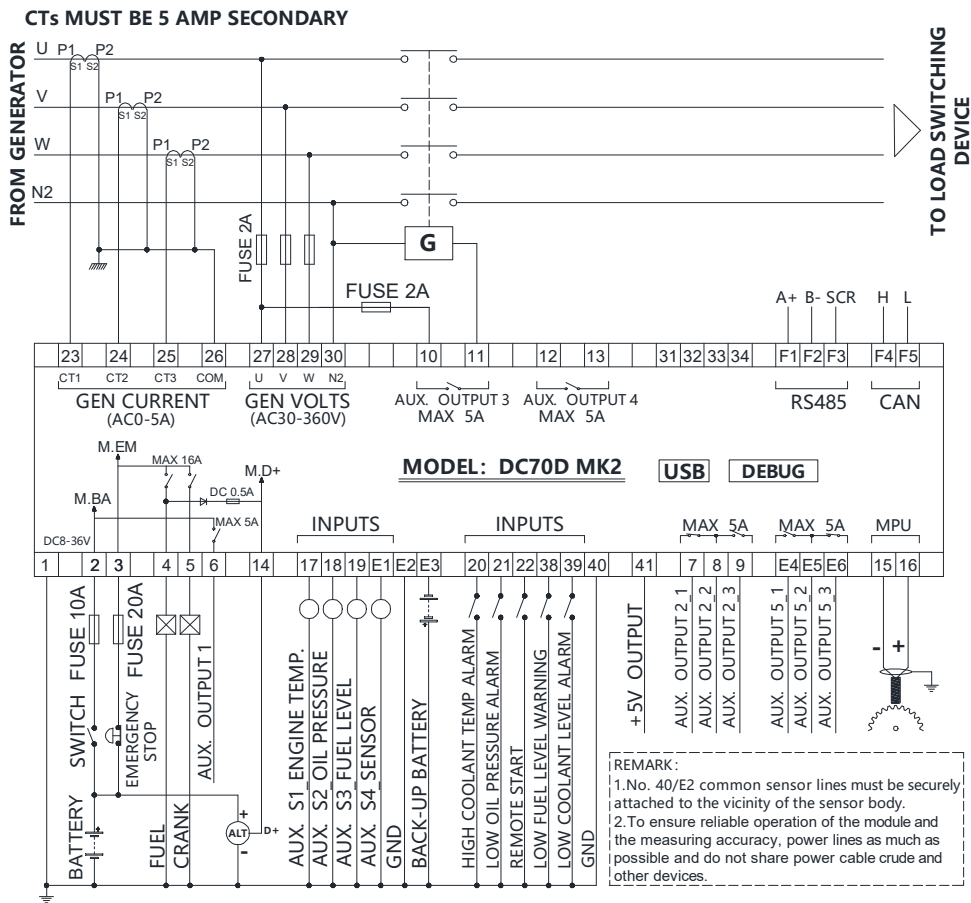

**⚠ Note: Please don't move battery during running status or it may cause the controller broken!**

**⚠ WARNING: When generator is on-load, C. T. secondary must not be open circuit, Otherwise, the high voltage generated will pose a danger to personal safety.**

◆ **DC72D MK2 3-phase 4-wire Typical Wiring Diagram**

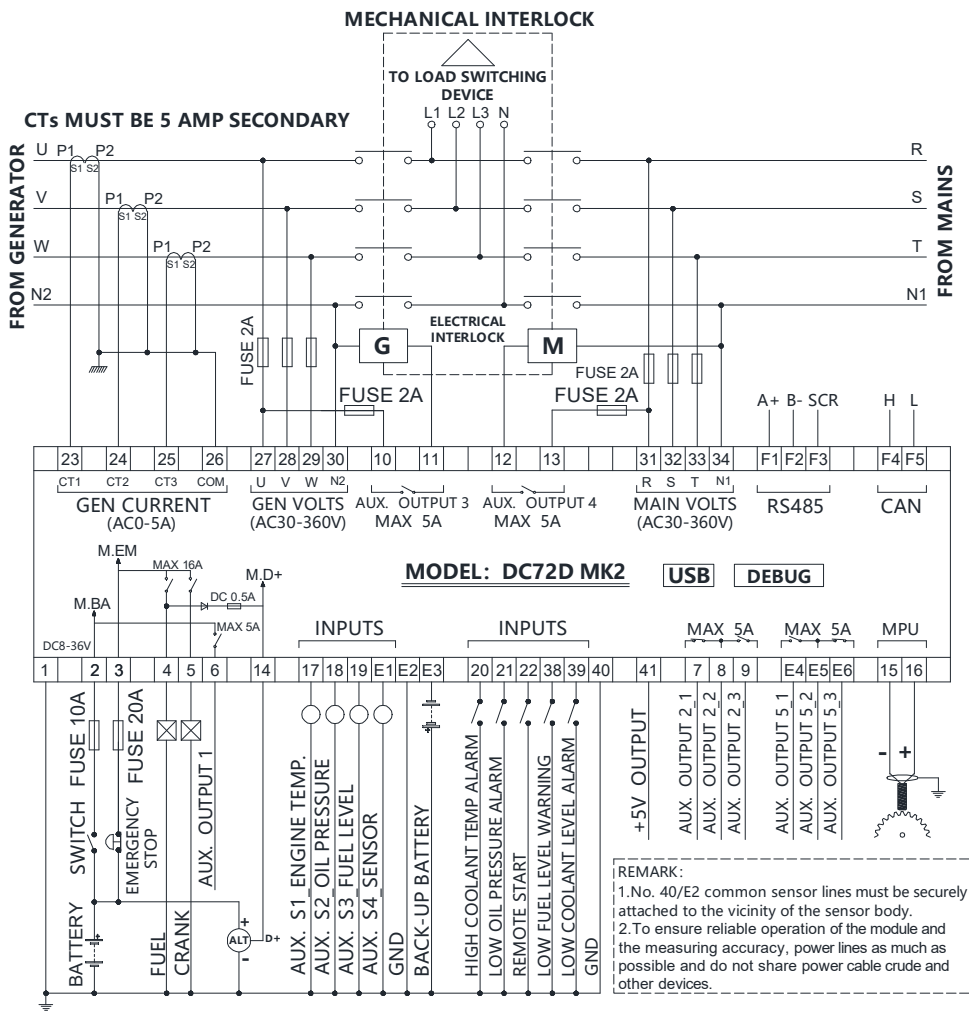

**Note: Please don't move during running status or it may cause the controller broken!**



**WARNING:** When generator is on-load, C. T. secondary must not be open circuit, Otherwise, the high voltage generated will pose a danger to personal safety.

◆ **DC70D MK2 1-phase 2-wire Typical Wiring Diagram**

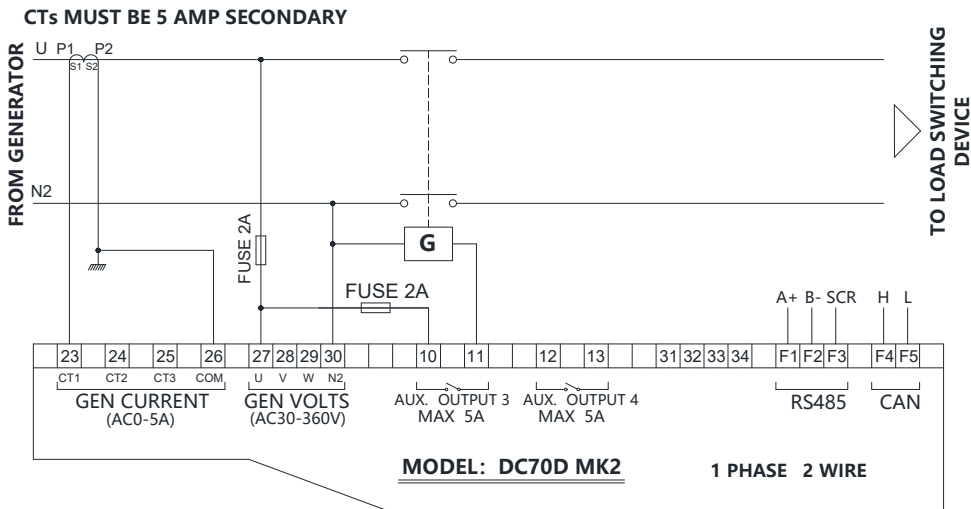

◆ **DC70D MK2 2-phase 3-wire Typical Wiring Diagram**

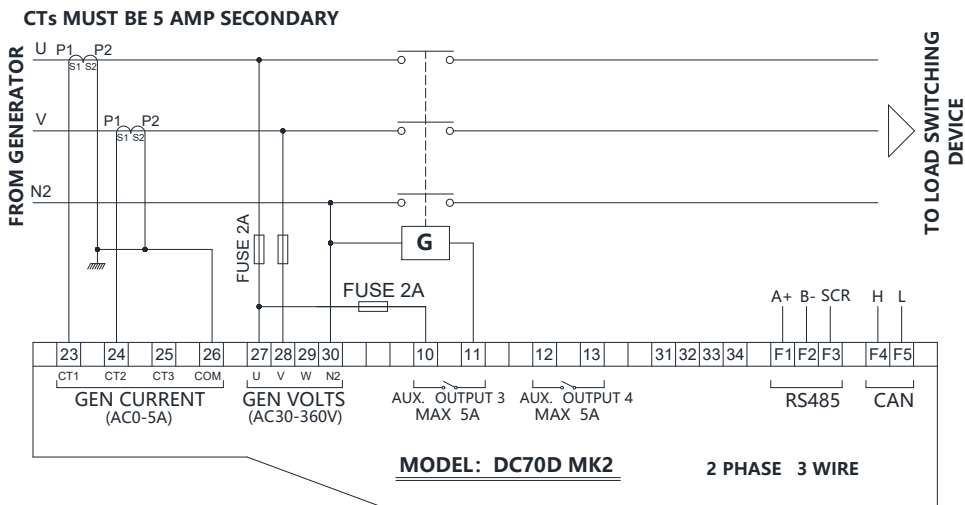

◆ **DC72D MK2 1-phase 2-wire Typical Wiring Diagram**

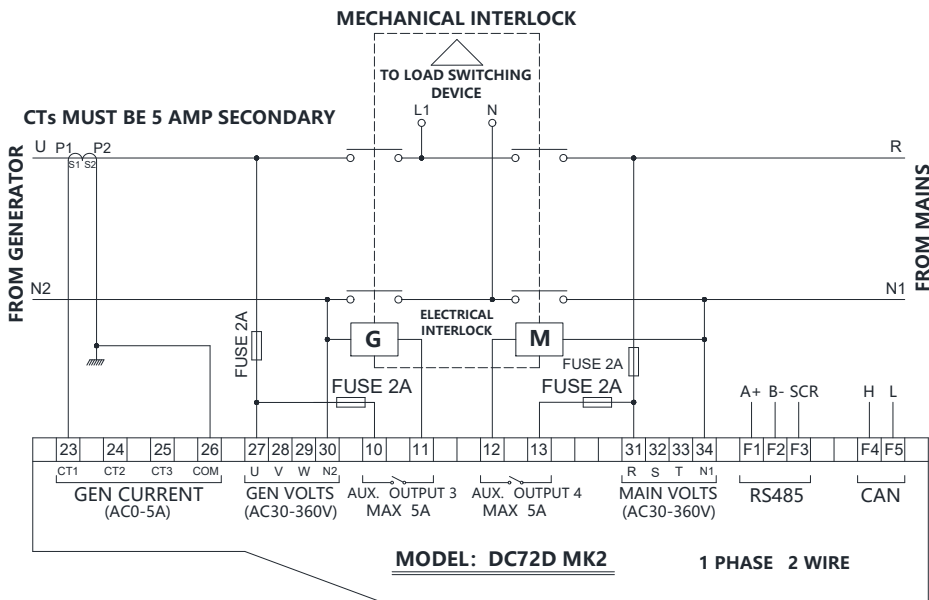

◆ **DC72D MK2 2-phase 3-wire Typical Wiring Diagram**

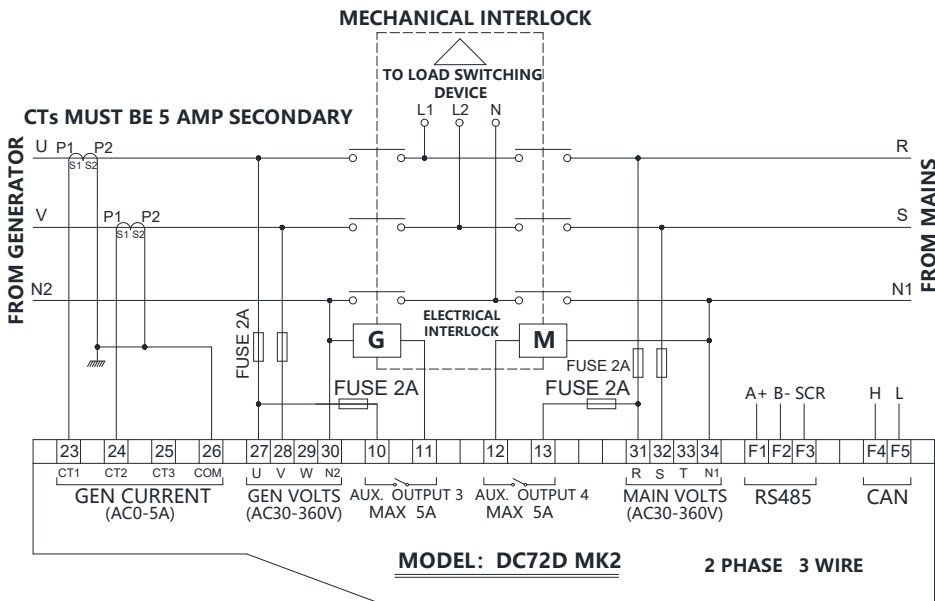



## 7. Installation instruction

- ◆ The controller is fixed by four special fixing members and screws, and the screws of the metal fasteners cannot be too tight.
- ◆ Panel Cutout: W220mm\*H160mm.

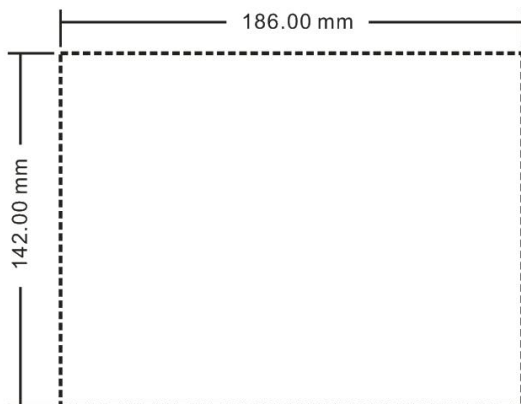

**Note:** If the controller is installed directly in the genset shell or other fluctuated equipment, the rubber pad must be installed.

### ◆ Battery Voltage Input

DC7xD MK2 controller is suitable for 8-36V DC battery voltage. Battery negative must be reliably connected to the enclosure of the engine. The controller power supply B+ and B- must be connected to battery positive and negative, and the wire size must not be less than 2.5mm<sup>2</sup>.



NOTE:

In case of floating charger connect charger output to battery positive and negative directly, then, connect battery positive and negative poles to controller positive and negative power supply.

### ◆ Output and relay expansion



Note: All outputs of the controller are relay contacts. The maximum current capacity is described in the "Parameters" in this manual. Please use it in the relay current capacity. If an extended relay is needed, add a continuous current diode (when the extended relay coil is DC) or a resistance-capacitance loop (when the extended relay coil is AC) to both ends of the coil to prevent interference with the controller or other equipment.

### ◆ AC current input

Current transformer with rated secondary current 5A must be externally connected to the controller current input.



**WARNING:** When generator is on-load, C. T. secondary must not be open circuit, Otherwise, the high voltage generated will pose a danger to personal safety.

◆ **Withstanding voltage test**



If withstanding voltage test is conducted after the controller has already been installed onto the control panel, please unplug all controller terminal connections in order to prevent high voltage from damaging it.

**8. Panel and display**

◆ **DC70D MK2**

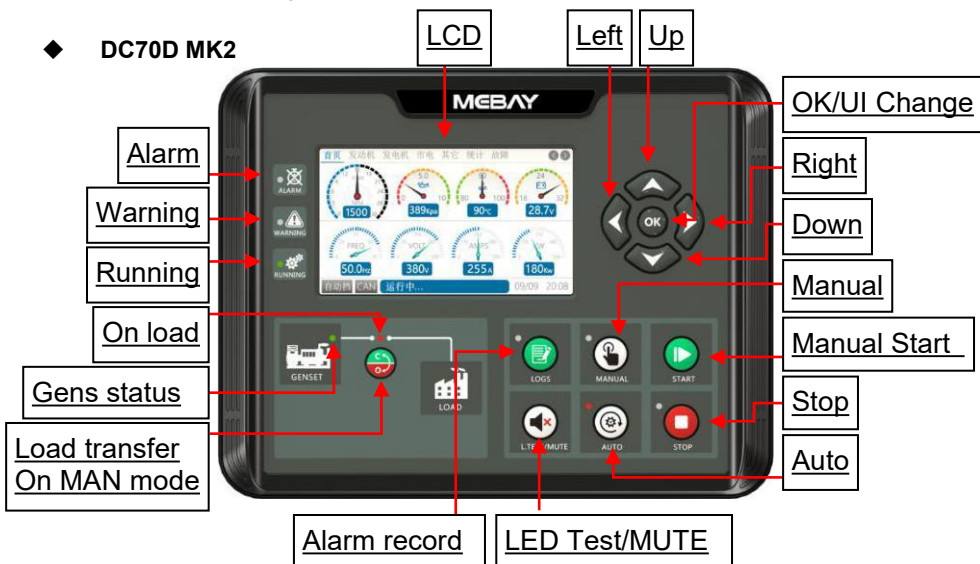



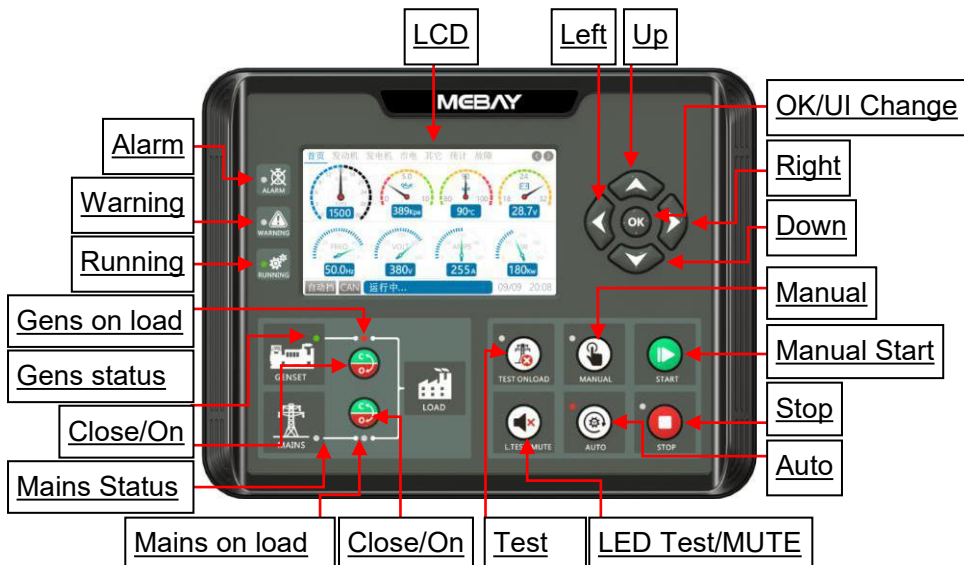

◆ **DC72D MK2**



**◆ Key Function Description**

KEYS	NAME	Main Function
	Stop Reset Revert	<ul style="list-style-type: none"> <li>◆ Can stop generator under manual/auto mode;</li> <li>◆ Can reset shutdown alarm</li> <li>◆ During stop procession, pressing this key again can stop generator immediately.</li> <li>◆ Pressing this key can cancel the setting and back to upper class under edition.</li> <li>◆ Under the setting mode with checking data, the data can be saved and system will exit after pressing.</li> </ul>
	Start	<ul style="list-style-type: none"> <li>◆ Start the genset under manual mode.</li> <li>◆ Pressing this key can start the genset under manual testing mode.</li> <li>◆ In STOP mode, Press this key, "Fuel output" and "ECU power" will output.</li> </ul>
	Manual	<ul style="list-style-type: none"> <li>◆ Pressing this key will set the module into manual mode.</li> </ul>
	Auto	<ul style="list-style-type: none"> <li>◆ Pressing this key will set the module into auto mode.</li> </ul>
	DC70D MK2 Records	<ul style="list-style-type: none"> <li>◆ Pressing this key to check the alarm records under stop mode.</li> </ul>
	DC72D MK2 Test	<ul style="list-style-type: none"> <li>◆ Pressing this key to come into manual testing mode.</li> <li>◆ Under testing mode, pressing MANUAL can start the genset and transfer to normal loading after running which is to test if the auto start is in normal status.</li> </ul>
	LED Test/ Warning clear	<ul style="list-style-type: none"> <li>◆ Test if all LED lights are ok, pressing this key to test if all lighted, all off when loosen it.</li> <li>◆ Under warning, pressing this key can clear warning and controller will re-check warning.</li> <li>◆ Under alarm, pressing this key can clear the buzzer call.</li> <li>◆ Pressing this key in 3 seconds can clear the buzzer call, pressing it again in 3 seconds can recover the buzzer call.</li> </ul>
	Gens/ Mains Close/On	<ul style="list-style-type: none"> <li>◆ Under manual mode, pressing this key can transfer load to genset/mains.</li> </ul>
	Left	<ul style="list-style-type: none"> <li>◆ Under display mode, pressing this key to turn left page.</li> <li>◆ Under edition mode, pressing this key to move the digit.</li> </ul>
	Right	<ul style="list-style-type: none"> <li>◆ Under display mode, pressing this key to turn right page.</li> <li>◆ Under edition mode, pressing this key to move the digit.</li> </ul>

	Up	<ul style="list-style-type: none"> <li>◆ Under display mode, parts of the page can move up.</li> <li>◆ Under edition mode, pressing this key to move the digit or increase the numbers.</li> <li>◆ Under records mode, pressing this key to move the digit.</li> </ul>
	Down	<ul style="list-style-type: none"> <li>◆ Under display mode, parts of the page can move down.</li> <li>◆ Under edition mode, pressing this key to move the digit or decrease the numbers.</li> <li>◆ Under records mode, pressing this key to move the digit.</li> </ul>
	OK UI Change	<ul style="list-style-type: none"> <li>◆ Confirm the change under edition mode.</li> <li>◆ Page exited under records checking mode.</li> <li>◆ Black UI and white UI can be switched when Pressing.</li> <li>◆ In standby state, press for 3 seconds to enter the parameter setting mode.</li> </ul>
	Setting mode	<ul style="list-style-type: none"> <li>◆ Pressing OK and STOP simultaneously to come into setting mode</li> </ul>
	DC72D MK2 Alarm Records checking	<ul style="list-style-type: none"> <li>◆ Pressing STOP and RIGHT to check the records and any buttons pressed to exit from the page.</li> </ul>

### ◆ Engine flywheel teeth automatic adjustment

1) Crank disconnect must be set to include both "speed" and "frequency" options.

2) When the generator frequency and engine speed are not zero, press 

and  for more than 0.5 seconds, the controller will automatically calculate and save the number of flywheel teeth according to the generation frequency and generator poles.

3) After calculating and saving the number of flywheel teeth successfully, the controller shows: "**Flywheel xxx teeth, saved successfully!**"



### ◆ Alarm records checking



DC7xD MK2 controller can save 100 groups of alarm records which contains the alarm record data includes detailed data such as alarm time, generator parameters, engine parameters, etc.

How to check the alarm records:

1) Enter alarm record page:

a) DC70D MK2: under stop mode, press  to come into alarm records page;

b) DC72D MK2: press  and  simultaneously to come into alarm records page;

2) Press  to turn upper digit and press  to turn lower digit in order to choose the record you need. Press  to confirm the record and come into history records checking page.

- 3) Press to turn lower records under records checking page. Press to turn upper records and press to revert back to alarm history records page.
- 4) Exit from records page: In the history records page and checking page, press to exit;

#### ◆ View controller system log

DC7xD MK2 series generator set controller can save 5000 system logs, including operation time, generator set startup, key operation, parameter modification, controller power on and other records.

The steps to view the system log are as follows:

- 1) Press the key for more than 3 seconds. Or press the stop key without releasing, press the OK key again, and then release all the keys to enter the setting menu page;
- 2) In the setting menu page, select "**System logs**" and press the OK key to enter the password input page;
- 3) Enter the controller parameter setting password, and the default factory password is "**07623**"; after entering the password, press the OK key once to enter the system log page;
- 4) In the system log page, press the up key and down key to browse the operation log, and the latest operation is recorded in the front; press the STOP key to exit the system log page.

## 9. Control and operation instruction

### ◆ Manual test mode: (only DC72D MK2 has this function)

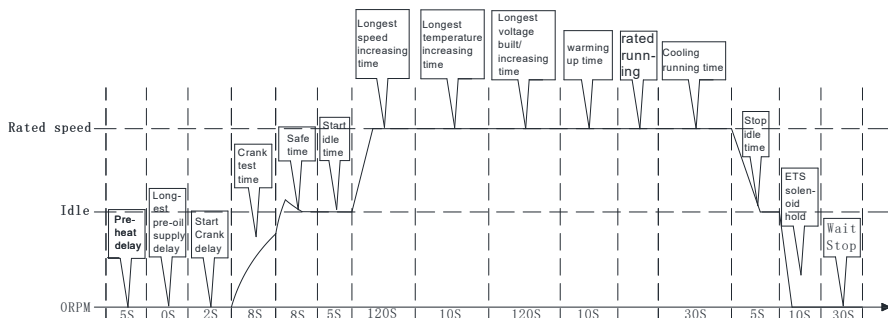

Press and make sure it is in the stop position before starting.

Press "". and the test file indicator is on. At this time, it is detected whether the connection of each sensor is normal. If the sensor is open, the sensor opens an alarm. If it is normal, the unit start process is executed in the following sequence after pressing the "". automatically switch to Generator provide the power when the unit is running normally. Press "". The controller performs the parking process at the following timing:





◆ Manual Start Mode

press  and make sure it is in the stop position before starting.

Press  and the test file indicator is on. At this time, it is detected whether the connection of each sensor is normal. If the sensor is open, the sensor opens an alarm. If it is normal, the unit start process is executed in the following sequence after pressing the . automatically switch to Generator provide the power when the unit is running normally. Press  The controller performs the parking process at the following timing:

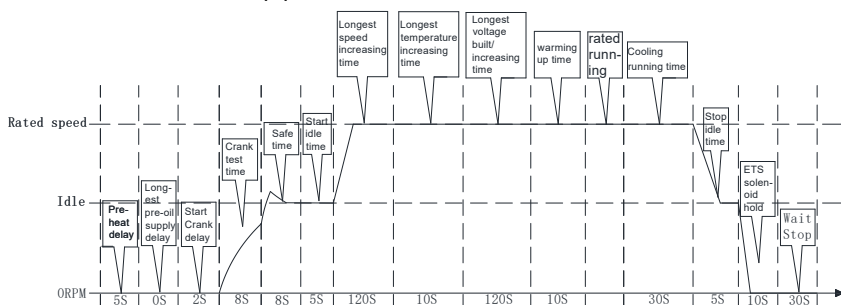
Manual start and stop process:



After the manual start is successful, pressing the "automatic key"  can be converted into an automatic file. The specific working time is as follows:

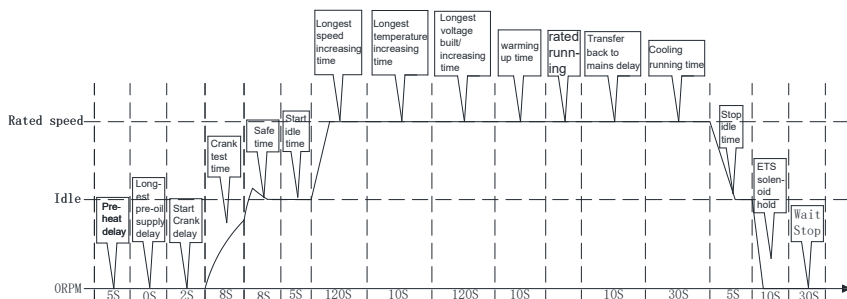



◆ **Emergency Start**

In the manual mode, press the "manual"  button and the "start"  button at the same time to start the generator set in case of emergency.

At this time, the controller does not judge whether the engine has been started successfully according to the successful starting conditions. The disengagement of the starter must be controlled by the operator. When the operator observes that the unit has been started successfully, releasing the key, the starter stops output, and the controller enters the safety delay.

◆ **Automatic starting mode:**

press  and make sure it is in the stop position before starting.

Press  and the test file indicator is on. At this time, it is detected whether the connection of each sensor is normal. If the sensor is open, the sensor opens an alarm. If it is normal, wait for the remote start signal to be valid (DC72D MK2 detected the remote starting signal is valid or the mains provide the power is invalid). The unit will perform the starting process in the following sequence. When the unit enters the normal rated operation, it will automatically switch to the generator provide the power. The controller will detect the remote start signal and the mains status in real time (DC72D MK2 is available). When the remote start signal fails and the mains provide the power returns to normal, the shutdown process after the "loop time delay" is performed (DC72D MK2 is available).

Auto start and stop process:

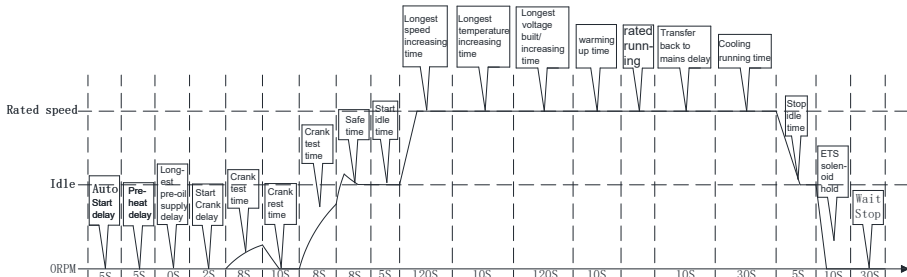



◆ **Notices in Starting Process**

 Note 1: During the Cranking time, the controller automatically detects the speed signal, frequency signal and oil pressure value or the charging voltage (according to the parameter setting) to reach the judgment condition of successful start, then the judgment is that the start is successful and the motor relay is closed.

 Note 2: Within the safety delay, only respond to emergency stop, immediate stop, over speed, over frequency, Over voltage, ECU communication Failure, shutter open abnormal, other alarms are not responded to.

 Note 3: No response to alarm and warning of under speed, low frequency, under voltage, over current, over power, non-balance of current, external instant unloading shutdown, during start idle time.

 Note 4: No response to low frequency, under voltage, over current non-balance of current, external instant unloading shutdown and over power is required when entering the RPM-up time.

 Note 5: No response to low frequency, under voltage, over current non-balance of current, external instant unloading shutdown and over power is required when entering the temperature-up time.

 Note 6: No response to low frequency, under voltage, over current non-balance of current, external instant unloading shutdown and over power is required when entering the Voltage-up time.

 Note 7: No response to low frequency, under voltage, over current non-balance of current, external instant unloading shutdown and over power is required when entering the Warming-up time.

 Note 8: After entering rated operation, the Gens load relay output.

 Note 9: In the process of shutdown, if the remote starting signal is restored to be valid within the "Cooling time", the rated operation will be entered again.

 Note 10: If the stop key is pressed again during idle time, the idle time will be canceled and the stop operation will be executed directly.

## 10. Warnings and Shutdown Alarms

### ◆ Warnings

 Notes: Warning is a non-serious failure state, which will not harm the gensets system for the time being. It only reminds operators to pay attention to the situation that does not meet the requirements and solve it in time to ensure the continuous operation of the system. When the warning occurs, the gensets does not stop. Once the fault is removed, the warning is automatically canceled.



### Over Speed Warning

When the controller detects that the engine speed is higher than "**Over speed warning**", Then start warning delay and the duration (Normal warning delay) have not returned to normal, the warning of over speed is reported. "**WARNING**" lights will light up, Generators will not stop, displays "**Over speed**" on the current fault screen.

### Under Speed Warning

When the controller detects that the engine speed is lower than "**Under speed warning**", Then start warning delay and the duration (Normal warning delay) have not returned to normal, the warning of under speed is reported. "**WARNING**" lights will light up, Generators will not stop, displays "**Under speed**" on the current fault screen.

### Low Oil Pressure Sensor Warning

When the controller parameter "**Action if low oil pressure**" is set to "**Warning**" and the AUX. INPUT port "**Low oil pressure shutdown disabled**" switch is valid, and the controller detects that the engine Oil Pressure is lower than "**Low oil pressure warning**", Then start warning delay and the duration (Normal alarm delay) have not returned to normal, the warning of low Oil Pressure is reported. "**WARNING**" lights will light up, Generators will not stop, displays "**Low OP sensor**" on the current fault screen.

### High Coolant temperature sensor warning

When the controller parameter "**Action if high water temperature**" is set to "**Warning**" and the AUX. INPUT port "**High water temperature disabled**" switch is valid, and the controller detects that the coolant temperature value is higher than the "**High coolant temperature warning**", Then start warning delay and the duration (Normal alarm delay) have not returned to normal, the warning of High coolant temperature warning is reported. "**WARNING**" lights will light up, Generators will not stop, displays "**High WT sensor**" on the current fault screen.

### High oil temperature sensor warning

When the controller parameter "**Action if high water temperature**" is set to "**Warning**" and the AUX. INPUT port "**High oil temperature shutdown disabled**" switch is valid, and the controller detects that the oil temperature value is higher than the "**High oil temperature warning**", Then start warning delay and the duration (Normal alarm delay) have not returned to normal, the warning of High oil temperature warning is reported. "**WARNING**" lights will light up, Generators will not stop, displays "**High OT sensor**" on the current fault screen.

### High cylinder temperature sensor warning

When the controller parameter "**Action if high cylinder temperature**" is set to "**Warning**" and the AUX. INPUT port "**High cylinder temperature shutdown disabled**" switch is valid, and the controller detects that the cylinder temperature value is higher than the "**High cylinder temperature warning**", Then start warning delay and the duration (Normal alarm delay) have not returned to normal, the warning of High cylinder temperature warning is reported. "**WARNING**" lights will light up, Generators will not stop, displays "**High CT sensor**" on the current fault screen.

### High genset box temperature sensor warning

When the controller parameter **"Action if high genset box temperature"** is set to **"Warning"** and the AUX. INPUT port **"High genset box temperature shutdown disabled"** switch is valid, and the controller detects that the genset box temperature value is higher than the **"High genset box temperature warning"**, Then start warning delay and the duration (Normal alarm delay) have not returned to normal, the warning of High genset box temperature warning is reported. **"WARNING"** lights will light up, Generators will not stop, displays **"High Box Temp-A"** on the current fault screen.

### Low fuel level sensor warning

When the controller detects that the fuel level value is lower than the **"Low fuel level warning"**, Then start warning delay and the duration (Normal alarm delay) have not returned to normal, the warning of Low fuel level warning is reported. **"WARNING"** lights will light up, Generators will not stop, displays **"Low fuel level-A"** on the current fault screen.

### Low fuel level switch warning

When the controller detects that the AUX. INPUT **"Low fuel level warning input"** switch is active, it starts warning delay and lasts for Normal alarm delay. When the **"Low fuel level warning input"** switch is enabled, the engine low fuel level switch warning is reported. **"WARNING"** lights will light up, Generators will not stop, displays **"Low fuel level-D"** on the current fault screen.

### Low oil level switch warning

When the controller detects that the AUX. INPUT **"Low oil level warning input"** switch is active, it starts warning delay and lasts for Normal alarm delay. When the **"Low oil level warning input"** switch is enabled, the engine low oil level switch warning is reported. **"WARNING"** lights will light up, Generators will not stop, displays **"Low oil level-D"** on the current fault screen.

### Over battery voltage warning

When the controller detects that the battery voltage is higher than the **"Over battery voltage warning"**, Then start warning delay and the duration (Normal alarm delay) have not returned to normal, the warning of Over battery voltage warning is reported. **"WARNING"** lights will light up, Generators will not stop, displays **"Over voltage"** on the current fault screen.

### External instant unloading switch warning

When the controller detects that the AUX. INPUT **"External instant unloading shutdown disabled"** switch is active, it starts warning delay and lasts for Normal alarm delay. When the **"External instant unloading shutdown disabled"** switch is enabled, the warning is reported. **"WARNING"** lights will light up, Generators will not stop, displays **"Unload switch"** on the current fault screen.

### External instant warning

When the controller detects that the AUX. INPUT **"External instant warning input"** switch is active, it starts warning delay and lasts for Normal alarm delay. When the **"External instant warning input"** switch is enabled, the warning is reported.

**"WARNING"** lights will light up, Generators will not stop, displays **"Instant warn"** on the current fault screen.

### **Speed signal lost warning**

When the controller parameter **"Action if RPM lost"** is set to **"warning"**, the detected speed value is 0, Then start warning delay and the duration (Normal alarm delay) have not returned to normal, the warning of speed signal lost warning is reported. **"WARNING"** lights will light up, Generators will not stop, displays **"Lose speed"** on the current fault screen.

### **Oil pressure sensor disconnected warning**

When the controller parameter **"Action if low oil pressure sensor disconnected"** is set to **"warning"**, When the oil pressure sensor is detected to be disconnected, Then start warning delay and the duration (Normal alarm delay) have not returned to normal, the warning of Oil pressure sensor disconnected warning is reported. **"WARNING"** lights will light up, Generators will not stop, displays **"OP sensor open"** on the current fault screen.

### **Coolant temperature sensor disconnected warning**

When the controller parameter **"Action if water temperature sensor disconnected"** is set to **"warning"**, When the coolant temperature sensor is detected to be disconnected, Then start warning delay and the duration (Normal alarm delay) have not returned to normal, the warning of coolant temperature sensor disconnected warning is reported. **"WARNING"** lights will light up, Generators will not stop, displays **"WT sensor open"** on the current fault screen.

### **Oil temperature sensor disconnected warning**

When the controller parameter **"Action if oil temperature sensor disconnected "** is set to **"warning"**, When the oil temperature sensor is detected to be disconnected, Then start warning delay and the duration (Normal alarm delay) have not returned to normal, the warning of oil temperature sensor disconnected warning is reported. **"WARNING"** lights will light up, Generators will not stop, displays **"OT sensor open"** on the current fault screen.

### **Cylinder temperature sensor disconnected warning**

When the controller parameter **"Action if cylinder temperature sensor disconnected "** is set to **"warning"**, When the cylinder temperature sensor is detected to be disconnected, Then start warning delay and the duration (Normal alarm delay) have not returned to normal, the warning of cylinder temperature sensor disconnected warning is reported. **"WARNING"** lights will light up, Generators will not stop, displays **"CT sensor open"** on the current fault screen.

### **Genset box temperature sensor disconnected warning**

When the controller parameter **"Action if genset box temperature sensor disconnected "** is set to **"warning"**, When the genset box temperature sensor is detected to be disconnected, Then start warning delay and the duration (Normal alarm delay) have not returned to normal, the warning of genset box temperature sensor disconnected warning is reported. **"WARNING"** lights will light up, Generators will not stop, displays **"BT sensor open"** on the current fault screen.

### Fuel Level sensor disconnected warning

When the controller parameter "**Action if fuel Level sensor disconnected**" is set to "**warning**", When the fuel Level sensor is detected to be disconnected, Then start warning delay and the duration (Normal alarm delay) have not returned to normal, the warning of fuel Level sensor disconnected warning is reported. "**WARNING**" lights will light up, Generators will not stop, displays "**FL sensor open**" on the current fault screen.

### Over frequency warning

When the controller detects that the generator frequency is higher than "**Over frequency warning**", Then start warning delay and the duration (Normal warning delay) have not returned to normal, the warning of over frequency is reported. "**WARNING**" lights will light up, Generators will not stop, displays "**Over frequency**" on the current fault screen.

### Under frequency warning

When the controller detects that the generator frequency is lower than "**Under frequency warning**", Then start warning delay and the duration (Normal warning delay) have not returned to normal, the warning of under frequency is reported. "**WARNING**" lights will light up, Generators will not stop, displays "**Under frequency**" on the current fault screen

### Over voltage warning

When the controller detects that the generator voltage is higher than "**Over voltage warning**", Then start warning delay and the duration (Normal warning delay) have not returned to normal, the warning of over voltage is reported. "**WARNING**" lights will light up, Generators will not stop, displays "**Over voltage**" on the current fault screen.

### Under voltage warning

When the controller detects that the generator voltage is lower than "**Under voltage warning**", Then start warning delay and the duration (Normal warning delay) have not returned to normal, the warning of under voltage is reported. "**WARNING**" lights will light up, Generators will not stop, displays "**Under voltage**" on the current fault screen

### Over current warning

When the controller detects that the generator current is higher than "**Phase current over-load warning**", Then start warning delay and the duration (Normal warning delay) have not returned to normal, the warning of over current is reported. "**WARNING**" lights will light up, Generators will not stop, displays "**Over current**" on the current fault screen.

### Non-balance current ratio warning

When the controller is t2 phase 3 wire or 3 phase 4 wire, the controller detects that the unbalance degree of the three-phase or two-phase current of the generator is

higher than the "**Non-balance current ratio warning**". Then start warning delay and the duration (Normal warning delay) have not returned to normal, the warning of Non-balance current ratio is reported. "**WARNING**" lights will light up, Generators will not stop, displays "**Unbalance of AMP**" on the current fault screen.

### **Over power warning**

When the controller detects that the generator power is higher than "**Over total power warning**", Then start warning delay and the duration (Normal warning delay) have not returned to normal, the warning of over power is reported. "**WARNING**" lights will light up, Generators will not stop, displays "**Over power**" on the current fault screen.

### **Generator loading failure**

When the controller parameter "**Gens breaker checking**" is set to "**warning**", When the ATS switch is switched, it is detected that the AUX. INPUT switch of "**Gens un/loading input**" is invalid. Then start warning delay and the duration (Normal warning delay) have not returned to normal, the warning of generator loading failure is reported. "**WARNING**" lights will light up, Generators will not stop, displays "**Gens onload fail**" on the current fault screen.

### **Generator unloading failure**

When the controller parameter "**Gens breaker checking**" is set to "**warning**", When the ATS switch is switched, it is detected that the AUX. INPUT switch of "**Gens un/loading input**" is still valid. Then start warning delay and the duration (Normal warning delay) have not returned to normal, the warning of generator unloading failure is reported. "**WARNING**" lights will light up, Generators will not stop, displays "**Gens unload fail**" on the current fault screen.

### **Mains loading failure**

When the controller parameter "**Mains breaker checking**" is set to "**warning**", When the ATS switch is switched, it is detected that the AUX. INPUT switch of "**Mains un/loading input**" is invalid. Then start warning delay and the duration (Normal warning delay) have not returned to normal, the warning of mains loading failure is reported. "**WARNING**" lights will light up, Generators will not stop, displays "**Mains onload fail**" on the current fault screen.

### **Mains unloading failure**

When the controller parameter "**Mains breaker checking**" is set to "**warning**", When the ATS switch is switched, it is detected that the AUX. INPUT switch of "**Mains un/loading input**" is still valid. Then start warning delay and the duration (Normal warning delay) have not returned to normal, the warning of mains unloading failure is reported. "**WARNING**" lights will light up, Generators will not stop, displays "**Mains unload fail**" on the current fault screen.

### **1<sup>st</sup> Maintenance expiration warning**

When the controller parameter "**Primary maintenance expire**" is set to "**warning**", when the primary countdown to maintenance is detected as "0" or primary

maintenance date less than current date, then start warning delay and the duration (normal alarm delay), the warning of maintenance expiration is reported. "**ALARM**" lights on, without stopping the engine, and displays "**1st maintain end**" on the LCD screen.

### 2<sup>nd</sup> Maintenance expiration warning

When the controller parameter "**Secondary maintenance expire**" is set to "**warning**", when the secondary countdown to maintenance is detected as "0" or second maintenance date less than current date, then start warning delay and the duration (normal alarm delay), the warning of maintenance expiration is reported. "**ALARM**" lights on, without stopping the engine, and displays "**2nd maintain end**" on the LCD screen.

### 3<sup>rd</sup> Maintenance expiration warning

When the controller parameter "**Third maintenance expire**" is set to "**warning**", when the third countdown to maintenance is detected as "0" or third maintenance date less than current date, then start warning delay and the duration (normal alarm delay), the warning of maintenance expiration is reported. "**ALARM**" lights on, without stopping the engine, and displays "**3rd maintain end**" on the LCD screen.

### ECU faults warning

When the controller detects the warning information of ECU, Then start warning delay and the duration (Normal alarm delay) have not returned to normal, the warning of ECU faults warning is reported. "**WARNING**" lights will light up, Generators will not stop, displays "**ECU faults warn**" on the current fault screen.

### ECU Communication Failure Warning

When the controller parameter "**CAN failure**" is set to "**warning**", and controller does not receive any message sent by ECU. It started to delay and lasted for some time (Normal alarm delay), but still did not receive the message from ECU, the warning of ECU faults warning is reported. "**WARNING**" lights will light up, Generators will not stop, displays "**ECU comm. fail**" on the current fault screen.

### Low coolant level switch warning

When the controller detects that the AUX. INPUT "**Low water level warning**" switch is active, it starts warning delay and lasts for Normal alarm delay. When the "**Low water level warning**" switch is enabled, the engine low coolant level switch warning is reported. "**WARNING**" lights will light up, Generators will not stop, displays "**Low water level**" on the current fault screen.

### Over battery voltage warning

When the controller detects that the battery voltage is over than the "**Over battery voltage warning**", Then start warning delay and the duration (Normal alarm delay) have not returned to normal, the warning of over battery voltage warning is reported. "**WARNING**" lights will light up, Generators will not stop, displays "**Over BATT volt**" on the current fault screen.

### Under battery voltage warning

When the controller detects that the battery voltage is lower than the "**Under battery voltage warning**", Then start warning delay and the duration (Normal alarm delay)

have not returned to normal, the warning of Under battery voltage warning is reported. **"WARNING"** lights will light up, Generators will not stop, displays **"Under BATT volt"** on the current fault screen.

### Charging failure warning

When the gap between D+ and B+ is over than this value, and there is charging failure but still high(normal warning delay), then charge failure warns. **"WARNING"** lights will light up, Generators will not stop, displays **"Charger fault"** on the current fault screen. Once the gap is lower than the value, warns clear.

### Floating charger fault warning

When the controller detects that the AUX. INPUT **"Charging failure warning"** switch is active, it starts warning delay and lasts for Normal alarm delay. When the **"Charging failure warning"** switch is enabled, the engine floating charger fault warning is reported. **"WARNING"** lights will light up, Generators will not stop, displays **"Batt charge fail"** on the current fault screen.

### ◆ Starting fault

#### Fail to Start

If the number of cranks exceeds the predetermined number of cranks, the failure of start-up will be reported if the start-up of the generating unit is still unsuccessful. **"ALARM"** lights on, without stopping the engine, and displays **"Crank failure "** on the current fault screen.

### ◆ Shutdown Alarms



Warning: After the Shutdown Alarm occurs, the system will be locked immediately and the generator set will be stopped. Only after troubleshooting, press



key to clear the alarm, can it be re-operated.



Notes: When the shutdown alarm failure occurs, the **"ALARM"** lights will light up and the generator unit automatically stops.

### Over Speed Alarm

When the controller detects that the engine speed is higher than **"Over speed alarm"**, Then start alarm delay and the duration (Emergency delay) have not lower than **"Over speed revert"**, the alarm of over speed is reported. **"ALARM"** lights will light up, Generator stops running, and displays **" Over speed "** on the current fault screen.

### Under Speed Alarm

When the controller detects that the engine speed is under than **"Under speed alarm"**, Then start alarm delay and the duration (Normal alarm delay) have not higher than **"Under speed revert"**, the alarm of under speed is reported. **"ALARM"** lights will light up, Generator stops running, and displays **" Under speed "** on the current fault screen.

### Low Oil Pressure Sensor Alarm

When the controller detects that the engine Oil Pressure is lower than "**Low oil pressure alarm**", Then start alarm delay and the duration (Normal alarm delay) have not returned to normal, the alarm of low Oil Pressure is reported. "**ALARM**" lights will light up, Generator stops running, and displays "**Low OP sensor**" on the current fault screen.

### Low oil pressure switch alarm

When the controller detects that the AUX. INPUT port "**Low oil pressure alarm input**" switch is active. Start low oil pressure switch alarm delay, for a period of time "Normal alarm delay" AUX. INPUT port "**low oil pressure alarm input**" switch is valid. Then the alarm, the public alarm light "**ALARM**" lights will light up, stop the unit operation, and display "**Low OP switch**" on the current fault screen.

### High coolant temperature sensor alarm

When the controller detects that the coolant temperature value is higher than the "**High coolant temperature alarm**", Then start alarm delay and the duration (Normal alarm delay) have not returned to normal, the alarm of High coolant temperature alarm is reported. "**ALARM**" lights will light up, Generator stops running, and displays "**High WT sensor**" on the current fault screen.

### High coolant temperature switch alarm

When the controller detects that the AUX. INPUT port "**High coolant temperature alarm switch**" switch is active. Start low oil pressure switch alarm delay, for a period of time "Normal alarm delay" AUX. INPUT port "**High coolant temperature alarm switch**" is valid. Then the alarm, the public alarm light "**ALARM**" lights will light up, stop the unit operation, and display "**High WT switch**" on the current fault screen.

### High oil temperature sensor alarm

When the controller detects that the oil temperature value is higher than the "**High oil temperature alarm**", Then start alarm delay and the duration (Normal alarm delay) have not returned to normal, the alarm of High oil temperature alarm is reported. "**ALARM**" lights will light up, Generator stops running, and displays "**High OT sensor**" on the current fault screen.

### High oil temperature switch alarm

When the controller detects that the AUX. INPUT port "**High oil temperature alarm switch**" switch is active. Start low oil pressure switch alarm delay, for a period of time "Normal alarm delay" AUX. INPUT port "**High oil temperature alarm switch**" is valid. Then the alarm, the public alarm light "**ALARM**" lights will light up, stop the unit operation, and display "**High OT switch**" on the current fault screen.

### High cylinder temperature sensor alarm

When the controller detects that the cylinder temperature value is higher than the "**High cylinder temperature alarm**", Then start alarm delay and the duration (Normal alarm delay) have not returned to normal, the alarm of High cylinder temperature alarm is reported. "**ALARM**" lights will light up, Generator stops running,



and displays "**High CT sensor**" on the current fault screen.

### High cylinder temperature switch alarm

When the controller detects that the AUX. INPUT port "**High cylinder temperature alarm switch**" switch is active. Start low oil pressure switch alarm delay, for a period of time "Normal alarm delay" AUX. INPUT port "**High cylinder temperature alarm switch**" is valid. Then the alarm, the public alarm light "**ALARM**" lights will light up, stop the unit operation, and display "**High CT switch**" on the current fault screen.

### High genset box temperature sensor alarm

When the controller detects that the genset box temperature value is higher than the "**High genset box temperature alarm**", Then start alarm delay and the duration (Normal alarm delay) have not returned to normal, the alarm of High genset box temperature alarm is reported. "**ALARM**" lights will light up, Generator stops running, and displays "**High Box Temp-A**" on the current fault screen.

### High genset box temperature switch alarm

When the controller detects that the AUX. INPUT port "**High genset box temperature alarm switch**" switch is active. Start low oil pressure switch alarm delay, for a period of time "Normal alarm delay" AUX. INPUT port "**High genset box temperature alarm switch**" is valid. Then the alarm, the public alarm light "**ALARM**" lights will light up, stop the unit operation, and display "**High Box Temp-D**" on the current fault screen.

### Low fuel level sensor alarm

When the controller detects that the fuel level value is lower than the "**Low fuel level alarm**", Then start alarm delay and the duration (Normal alarm delay) have not returned to normal, the alarm of Low fuel level alarm is reported. "**ALARM**" lights will light up, Generator stops running, and displays "**Low fuel level-A**" on the current fault screen.

### Low fuel level switch alarm

When the controller detects that the AUX. INPUT "**Low fuel level alarm input**" switch is active, it starts alarm delay and lasts for Normal alarm delay. When the "**Low fuel level alarm input**" switch is enabled, the engine low fuel level switch alarm is reported. "**ALARM**" lights will light up, Generator stops running, and displays "**Low fuel level-D**" on the current fault screen.

### Low oil level switch alarm

When the controller detects that the AUX. INPUT "**Low oil level alarm input**" switch is active, it starts alarm delay and lasts for Normal alarm delay. When the "**Low oil level alarm input**" switch is enabled, the engine low oil level switch alarm is reported. "**ALARM**" lights will light up, Generator stops running, and displays "**Low oil level-D**" on the current fault screen.

### External instant unloading switch alarm

When the controller detects that the AUX. INPUT "**External instant unloading shutdown**" switch is active, it starts alarm delay and lasts for Normal alarm delay.

When the **"External instant unloading shutdown"** switch is enabled, the alarm is reported. **"ALARM"** lights will light up, Generators will not stop, displays **"Unload switch"** on the current fault screen.

### External instant alarm

When the controller detects that the **"External instant alarm input"** switch of the AUX. INPUT port is valid, the external instant trip is started and the shutdown alarm delay is delayed for a period of time **"Normal alarm delay"** AUX. INPUT port **"External instant alarm input"** switch When it is valid, it will alarm, the public alarm light **"ALARM"** lights will light up, Generator stops running, and display **"Instant parking"** on the current fault screen.

### Speed signal lost alarm

When the controller parameter **"Action if RPM lost"** is set to **"alarm"**, the detected speed value is 0, Then start alarm delay and the duration (Normal alarm delay) have not returned to normal, the alarm of speed signal lost warning is reported. **"ALARM"** lights will light up, Generator stops running, displays **"Lose speed"** on the current fault screen.

### Oil pressure sensor disconnected alarm

When the controller parameter **"Action if low oil pressure sensor disconnected"** is set to **"alarm"**, When the oil pressure sensor is detected to be disconnected, Then start alarm delay and the duration (Normal alarm delay) have not returned to normal, the alarm of Oil pressure sensor disconnected alarm is reported. **"ALARM"** lights will light up, Generator stops running, displays **"OP sensor open"** on the current fault screen.

### Coolant temperature sensor disconnected alarm

When the controller parameter **"Action if water temperature sensor disconnected"** is set to **"alarm"**, When the coolant temperature sensor is detected to be disconnected, Then start alarm delay and the duration (Normal alarm delay) have not returned to normal, the alarm of coolant temperature sensor disconnected alarm is reported. **"ALARM"** lights will light up, Generator stops running, displays **"WT sensor open"** on the current fault screen.

### Oil temperature sensor disconnected alarm

When the controller parameter **"Action if oil temperature sensor disconnected "** is set to **"alarm"**, When the oil temperature sensor is detected to be disconnected, Then start alarm delay and the duration (Normal alarm delay) have not returned to normal, the alarm of oil temperature sensor disconnected alarm is reported. **"ALARM"** lights will light up, Generator stops running, displays **"OT sensor open"** on the current fault screen.

### Cylinder temperature sensor disconnected alarm

When the controller parameter **"Action if cylinder temperature sensor disconnected "** is set to **"alarm"**, When the cylinder temperature sensor is detected to be disconnected, Then start alarm delay and the duration (Normal alarm delay) have not returned to normal, the alarm of cylinder temperature sensor disconnected alarm is reported. **"ALARM"** lights will light up, Generator stops running, displays **"CT sensor open"** on the current fault screen.

### **Genset box temperature sensor disconnected alarm**

When the controller parameter "**Action if genset box temperature sensor disconnected**" is set to "**alarm**", When the genset box temperature sensor is detected to be disconnected, Then start alarm delay and the duration (Normal alarm delay) have not returned to normal, the alarm of genset box temperature sensor disconnected alarm is reported. "**ALARM**" lights will light up, Generator stops running, displays "**BT sensor open**" on the current fault screen.

### **Fuel Level sensor disconnected alarm**

When the controller parameter "**Action if fuel Level sensor disconnected**" is set to "**alarm**", When the fuel Level sensor is detected to be disconnected, Then start alarm delay and the duration (Normal alarm delay) have not returned to normal, the alarm of fuel Level sensor disconnected alarm is reported. "**ALARM**" lights will light up, Generator stops running, displays "**FL sensor open**" on the current fault screen.

### **Over frequency alarm**

When the controller detects that the generator frequency is higher than "**Over frequency alarm**", Then start alarm delay and the duration (Emergency delay) have not returned to normal, the alarm of over frequency is reported. "**ALARM**" lights will light up, Generator stops running, displays "**Over frequency**" on the current fault screen.

### **Under frequency alarm**

When the controller detects that the generator frequency is lower than "**Under frequency alarm**", Then start alarm delay and the duration (Normal alarm delay) have not returned to normal, the alarm of under frequency is reported. "**ALARM**" lights will light up, Generator stops running, displays "**Under frequency**" on the current fault screen

### **Over voltage alarm**

When the controller detects that the generator voltage is higher than "**Over voltage alarm**", Then start alarm delay and the duration (Normal alarm delay) have not returned to normal, the alarm of over voltage is reported. "**ALARM**" lights will light up, Generator stops running, displays "**Over voltage**" on the current fault screen.

### **Under voltage alarm**

When the controller detects that the generator voltage is lower than "**Under voltage alarm**", Then start alarm delay and the duration (Normal alarm delay) have not returned to normal, the alarm of under voltage is reported. "**ALARM**" lights will light up, Generator stops running, displays "**Under voltage**" on the current fault screen.

### **Over current alarm**

When the controller detects that the generator phase current is higher than "**Phase current over-load alarm**", Then start alarm delay and the duration (Normal alarm delay) have not returned to normal, the alarm of over current is reported. "**ALARM**" lights will light up, Generator stops running, displays "**Over current**" on the current fault screen.

### Non-balance current ratio alarm

When the controller is t2 phase 3 wire or 3 phase 4 wire, the controller detects that the unbalance degree of the three-phase or two-phase current of the generator is higher than the "**Non-balance current ratio alarm**". Then start alarm delay and the duration (Normal alarm delay) have not returned to normal, the alarm of Non-balance current ratio is reported. "**ALARM**" lights will light up, Generator stops running, displays "**Unbalance of AMP**" on the current fault screen.

### Over power alarm

When the controller detects that the generator power is higher than "**Over total power alarm**", Then start alarm delay and the duration (Normal alarm delay) have not returned to normal, the alarm of over power is reported. "**ALARM**" lights will light up, Generator stops running, displays "**Over power**" on the current fault screen.

### Generator loading failure

When the controller parameter "**Gens breaker checking**" is set to "**alarm**", When the ATS switch is switched, it is detected that the AUX. INPUT switch of "**Gens un/loading input**" is invalid. Then start alarm delay and the duration (Normal alarm delay) have not returned to normal, the alarm of generator loading failure is reported. "**ALARM**" lights will light up, Generator stops running, displays "**Gens unload fail**" on the current fault screen.

### Generator unloading failure

When the controller parameter "**Gens breaker checking**" is set to "**alarm**", When the ATS switch is switched, it is detected that the AUX. INPUT switch of "**Gens un/loading input**" is still valid. Then start alarm delay and the duration (Normal alarm delay) have not returned to normal, the alarm of generator unloading failure is reported. "**ALARM**" lights will light up, Generator stops running, displays "**Gens unload fail**" on the current fault screen.

### Mains loading failure

When the controller parameter "**Mains breaker checking**" is set to "**alarm**", When the ATS switch is switched, it is detected that the AUX. INPUT switch of "**Mains un/loading input**" is invalid. Then start alarm delay and the duration (Normal alarm delay) have not returned to normal, the alarm of mains loading failure is reported. "**ALARM**" lights will light up, Generator stops running, displays "**Mains unload fail**" on the current fault screen.

### Mains unloading failure

When the controller parameter "**Mains breaker checking**" is set to "**alarm**", When the ATS switch is switched, it is detected that the AUX. INPUT switch of "**Mains un/loading input**" is still valid. Then start alarm delay and the duration (Normal alarm delay) have not returned to normal, the alarm of mains unloading failure is reported. "**ALARM**" lights will light up, Generator stops running, displays "**Mains unload fail**" on the current fault screen.

### 1<sup>st</sup> Maintenance expiration alarm

When the controller parameter "**Primary maintenance expire**" is set to "**alarm**", when the primary countdown to maintenance is detected as "0" or primary maintenance date less than current date, then start alarm delay and the duration (normal alarm delay), the alarm of maintenance expiration is reported. "**ALARM**" lights on, without stopping the engine, and displays "**1st maintain end**" on the LCD screen.

### 2<sup>nd</sup> Maintenance expiration alarm

When the controller parameter "**Secondary maintenance expire**" is set to "**alarm**", when the secondary countdown to maintenance is detected as "0" or second maintenance date less than current date, then start alarm delay and the duration (normal alarm delay), the alarm of maintenance expiration is reported. "**ALARM**" lights on, without stopping the engine, and displays "**2nd maintain end**" on the LCD screen.

### 3<sup>rd</sup> Maintenance expiration alarm

When the controller parameter "**Third maintenance expire**" is set to "**alarm**", when the third countdown to maintenance is detected as "0" or third maintenance date less than current date, then start alarm delay and the duration (normal alarm delay), the alarm of maintenance expiration is reported. "**ALARM**" lights on, without stopping the engine, and displays "**3rd maintain end**" on the LCD screen.

### ECU faults alarm

When the controller detects the alarm information of ECU, Then start alarm delay and the duration (Normal alarm delay) have not returned to normal, the alarm of ECU faults alarm is reported. "**ALARM**" lights will light up, Generator stops running, displays "**ECU faults warn**" on the current fault screen.

### ECU communication failure alarm

When the controller parameter "**CAN failure**" is set to "**alarm**", and controller does not receive any message sent by ECU. It started to delay and lasted for some time (Normal alarm delay), but still did not receive the message from ECU, the alarm of ECU faults alarm is reported. "**ALARM**" lights will light up, Generator stops running, displays "**ECU comm. fail**" on the current fault screen.

### Low coolant level switch alarm

When the controller detects that the AUX. INPUT "**Low water level alarm**" switch is active, it starts alarm delay and lasts for Normal alarm delay. When the "**Low water level alarm**" switch is enabled, the engine low coolant level switch alarm is reported. "**ALARM**" lights will light up, Generator stops running, displays "**Low water level**" on the current fault screen.

### Louver opening exception alarm

When the controller detects that the AUX. INPUT "**Louver status input**" switch is active, it starts alarm delay and lasts for Normal alarm delay. When the "**Louver status input**" switch is enabled, the Louver status input alarm is reported. "**ALARM**" lights will light up, Generator stops running, displays "**Louver abnormal**" on the current fault screen.

### Emergency stop alarm

When the controller detects that the input voltage of PIN 3 is less than 2V, then start alarm delay and the duration (**0.5s**) have not returned to normal, the alarm of Emergency Stop is reported. "**ALARM**" lights will light up, Generator stops running, and displays "**Emergency stop**" on the current fault screen.

### Stop failure with speed alarm

When the controller detects that the speed is not "0" after the execution of the shutdown, the alarm of stop failure is reported. "**ALARM**" lights will light up and displays "**Stop fail-RPM**" on the current fault screen.

### Stop failure with frequency alarm

When the controller detects that the frequency is not "0" after the execution of the shutdown, the alarm of stop failure is reported. "**ALARM**" lights will light up and displays "**Stop fail-Hz**" on the current fault screen.

### Stop failure with pressure alarm

When the controller detects that the Oil **Pressure** is not "0" after the execution of the shutdown, the alarm of stop failure is reported. "**ALARM**" lights will light up and displays "**Stop fail-OP-A**" on the current fault screen.



### Stop failure with D+

When the controller detects that the D+ is not "0" after the execution of the shutdown, the alarm of stop failure is reported. "**ALARM**" lights will light up and displays "**Stop fail-D+**" on the current fault screen.



## 11. Parameters setting



### ◆ Enter the edition page



Please set the parameters according to below steps:





1)The setting mode can be activated after pressing  and  simultaneously, under the status of standby without any alarm. The default password is "**07623**".

2)Press  and add number 1, press  to reduce number 1, press  to turn

the digit into right, press  to turn the digit into left, press  once done. Then system comes into menu after confirmation of password setting. The screen will display error if password is wrong. The correct password should be put after pressing any button.

3)Press  to turn the digit into upper position, press  to turn the digit into lower position, press  to get into parameters setting page.

4)Press  to shift up the parameters, press  to shift down the parameters, press  to get into parameter changing page.

5)Press  to add number 1, press  to reduce number 1, press  to turn the digit into right and press  to turn the digit into left, press  once done. If the parameters setting is in the valid setting range, then it can be saved, if not, it can not be saved.

6) Press and to save the parameters and exit from edition page.

7) Press to revert back to last class if in any setting position.

Revert back to default: put password "97011" when coming into parameters setting, then all the parameters can be set as defaults.

Note: the data can't be saved if the user didn't press OK and STOP to confirm the setting.

### ◆ Parameter setting

#### 1) Basic setting

No	Parameter	Range (default)	Notes
0	Language	0-English 1-简体中文 2-繁体中文 3-Русский 4-Espanol 5-Türk dili 6-Français 7-Românesc 8-Polski 9-Português 10-Deutsch 11-한국어 12-Tiếng Việt 13-العربية 14-Bahasa Indonesia 15-فارسی;	Language option. Display language selection. 0: English, 1: Simplified Chinese, 2: Traditional Chinese, 3: Spanish, 4: Russian, 5: Turkish, 6: French, 7: Romanian, 8: Polish, 9: Portuguese, 10: German, 11: Korean, 12: Vietnamese, 13: Arabic 14: Bahasa Indonesia, 15: Persian.
1	Gens poles	2/4/6/8(4)	When the flywheel teeth is set as 0, the RPM will be resulted by frequency. Pole 2: 50Hz---3000RPM. Pole 4: 50Hz---1500RPM. Pole 6: 50Hz---1000RPM. Pole 8: 50Hz---750RPM
2	Gens AC system	Disable 1 phase 2 wire 2 phase 3 wire 3 phase 3 wire 3 phase 4 wire	Gens phases: No gens parameters can be displayed if setting as disable, which is applied to water pump genset.
3	CT rate	5-6000A/5A(500A/5A)	Used for setting genset CT primary current, secondary rated current 5A.
4	Rated frequency	40.0-80.0Hz(50.0Hz)	Setting generator rated frequency to choose the meter range and calculate the alarm value.
5	Rated phase voltage	30-30000V(230V)	Setting generator phase voltage to choose the meter range and calculate the alarm value.
6	Rated phase current	5-6000A(500A)	Setting generator phase current to choose the meter range and calculate the alarm value.
7	Rated total power	5-2000Kw (276Kw)	Set total power of generator to choose the

			meter range and calculate the average loading rate and alarm value.
8	Rated battery voltage	8.0-36.0V( <b>24.0V</b> )	Choose the meter range and calculate the alarm value.
9	Rated RPM	500-4500RPM( <b>1500</b> )	Choose the meter range and calculate the alarm value.
10	Flywheel teeth	0-300( <b>0</b> )	If the setting is 0, (RPM sensor Disabled), then RPM is resulted by Hz.
11	Action if over current	Warning <b>Alarm and stop</b> Trip stop	If the system is set as trip stop, then the unloading procession shall be acted and then stop with alarm.
12	Action if over power	Warning <b>Alarm and stop</b> Trip stop	If the system is set as trip stop, then the unloading procession shall be acted and then stop with alarm.
13	Action if RPM lost	Warning <b>Alarm and stop</b>	This fault can be checked only if there is gens frequency checked as one condition of crank successfully.
14	Action if low oil pressure	Warning <b>Alarm and stop</b>	If setting as warning,the AUX. INPUT should be set as Low oil pressure stop disabled and input is valid. When the oil pressure value is lower than the preset value or low oil pressure alarm input signal is valid, then controller only display warning but not stop.
15	Action if high water temperature	Warning <b>Alarm and stop</b> Alarm and stop after unloading	Alarm and stop: when the temperature is higher than preset value or high temperature signal is valid, then controller will alarm and stop after normal faults delay.
16	Action if high oil temperature	Warning <b>Alarm and stop</b> Alarm and stop after unloading	If setting as warning:the AUX. INPUT should be set as high temperature stop disabled and input is valid. When the temperature value is higher than the preset value or high temperature alarm input signal is valid, then controller only display warning but not stop.
17	Action if high cylinder temperature	Warning <b>Alarm and stop</b> Alarm and stop after unloading	If setting as alarm and stop after unloading:the AUX. INPUT should be set as high temperature stop and input is valid. When the temperature value is higher than the preset value or high temperature alarm input signal is valid, then controller shall start the unloading procession and stop with alarm.
18	Action if high genset box Temperature	Warning <b>Alarm and stop</b> Alarm and stop after unloading	
19	Action if oil pressure sensor disconnected	Disable <b>Warning</b> Alarm and stop	Action if oil pressure sensor disconnected.
20	Action if water temperature sensor	Disable <b>Warning</b> Alarm and stop	Action if Water temperature sensor disconnected.



	disconnected		
21	Action if oil temperature sensor disconnected	Disable <b>Warning</b> Alarm and stop	Action if oil temperature sensor disconnected.
22	Action if cylinder temperature sensor disconnected	Disable <b>Warning</b> Alarm and stop	Action if cylinder temperature sensor disconnected.
23	Action if genset box temperature sensor disconnected	Disable <b>Warning</b> Alarm and stop	Action if genset box temperature sensor disconnected.
24	Action if fuel Level I sensor disconnected	Disable <b>Warning</b> Alarm and stop	Action if Fuel level sensor disconnected.
25	Pressure/Temperature unit	°C/KPA <b>°C/BAR</b> °C/PSI F/KPA F/BAR F/PSI	Unit display.
26	Gens breaker checking	Disable <b>Warning</b> Alarm and stop	The according switch value input should be set as input checking terminal.
27	Mains breaker checking	Disable <b>Warning</b> Alarm and stop	The according switch value input should be set as input checking terminal.
28	Standby battery start condition	0.0V-60.0V( <b>0.0V</b> )	The genset will crank successfully when there is mains failure and ABF is lower than preset value. When it is set as 0 that ABF voltage can not be checked, then genset will be cranked once mains failure. (genset will be stopped once mains normal).
29	Gens volt. Primary(PT)	30-30000V( <b>100V</b> )	Generator voltage transformer primary voltage.
30	Gens volt. Secondary(PT)	30-30000V( <b>100V</b> )	Generator voltage transformer secondary voltage.
31	Mains volt. Primary(PT)	30-30000V( <b>100V</b> )	Mains voltage transformer primary voltage.
32	Mans volt. Secondary(PT)	30-30000V( <b>100V</b> )	Mains voltage transformer secondary voltage.

## 2) Basic Setting 2

NO	Parameter	Range(defaults)	Notes
1	Primary Modes	<b>STOP</b> Manual Auto Auto save	The primary modes on power, easy for user operation. Note: auto record function can not record the mode with load.

2	Manual crank times	1-30 ( <b>1 time</b> )	Crank times under mode and test mode.
3	Auto start crank times	1-30 ( <b>3 times</b> )	Crank times under auto mode.
4	Crank disconnect	RPM Hz Oil pressure(delay) D+ <b>RPM/Frequency</b> RPM/Oil Pressure RPM/ D+ Frequency/Oil Pressure Frequency / D+ Oil pressure/ D+ RPM/Frequency/Oil press. Frequency/oil Press./D+ Oil pressure/D+/RPM D+/Frequency/RPM RPM/Freq./Oil Press./D+	1.If there is no oil pressure sensor, please dont choose the type. 2.If there is no oil pressure sensor (only with low oil pressure switch),RPM, voltage, the user can choose Charge D+ as the crank condition, please choose oil pressure+Charge D+ as conditions in order to keep the engine running safely. Oil pressure switch input is not the crank condition Please check if the running status, stop condition are according with crank condition. Means either of the conditions can be acceptable as crank condition. But all of them should be meet together to regard as stop condition.
5	Frequency disconnect	0-200% <b>(28%)</b>	Rated frequency multiplying by this value is regarded as crank success condition. When the gens frequency is over the condition value, then system regards it as crank success.
6	Oil pressure disconnect	0-400kpa <b>(200kpa)</b>	When the engine oil pressure is over the condition value, then system regards it as crank success, motor escaped.
7	RPM disconnect	0-200% <b>(24%)</b>	Rated RPM multiplying by this value is regarded as crank success condition. When the RPM is over the condition value, then system regards it as crank success, motor escaped.
8	D+ disconnect	3.0-32.0V <b>(8.0V)</b>	When the engine D+ is over the condition value, then system regards it as crank success, motor escaped.
9	OP pre-supply stop	50-600kpa <b>(200kpa)</b>	When the oil pressure is over the condition value, then pre-oil supply is stopped.
10	RPM-up stop	0-200% <b>(90%)</b>	Rated RPM multiplying by this value is regarded as speed-up stop value. When the RPM is over this value, then the RPM-Up procession is stopped in time.
11	Temperature-up stop	20-200℃ <b>(68℃)</b>	When the water temperature is over the preset value, then temperature-up procession is stopped in time.
12	Voltage-up stop	0-200% <b>(85%)</b>	Rated voltage multiplying by this value is regarded as voltage-up stop value. When the voltage is over this value, then the

			voltage-Up procession is stopped in time.
13	Water temperature for Fan open	20-200°C (75 °C)	Used for controlling radiator: when the water temperature reaches the set temperature, then the radiator is opened.
14	Water temperature for Fan close	20-200°C (60 °C)	Used for controlling radiator: when the water temperature is lower than the set temperature, then the radiator is closed.
15	Oil temperature for fan open	20-200°C (75 °C)	Used for controlling radiator: when the fuel temperature reaches the set temperature, then the radiator is opened.
16	Oil temperature for fan close	20-200°C (60 °C)	Used for controlling radiator: when the fuel temperature is lower than the set temperature, then the radiator is closed.
17	Cylinder temperature for fan open	20-200°C (75 °C)	Used for controlling radiator: when the cylinder temperature reaches the set temperature, then the radiator is opened.
18	Cylinder temperature for fan close	20-200°C (60 °C)	Used for controlling radiator: when the cylinder temperature is lower than the set temperature, then the radiator is closed.
19	Genset box temp. for fan open	20-200°C (75 °C)	Used for controlling radiator: when the genset box temperature reaches the set temperature, then the radiator is opened.
20	Genset box temp. for fan close	20-200°C (60 °C)	Used for controlling radiator: when the genset box temperature is lower than the set temperature, then the radiator is closed.
21	Fuel pump open	0-100%(25%)	When the fuel level is lower than preset value and remains 10S, fuel pump opened signal output
22	Fuel pump close	0-100%(80%)	When the fuel level is higher than preset value and remains 1S, fuel pump closed signal output.
23	Primary Maintenance countdown	0-5000h(800h)	When it is set as 5000, then this function is disabled.
24	Secondary maintenance countdown	0-5000h(1000h)	
25	Third maintenance countdown	0-5000h(1200h)	
26	Primary maintenance date	2000/01/01-2099/12/31	When it is set as 2000/01/01, this function is disabled.
27	Secondary maintenance date	2000/01/01-2099/12/31	
28	Third maintenance date	2000/01/01-2099/12/31	
29	Primary maintenance expire	<b>Warning</b> Alarm and stop	The action after the primary maintenance expired.

30	Secondary maintenance expire	<b>Warning</b> Alarm and stop	The action after the secondary maintenance expired.
31	Third maintenance expire	<b>Warning</b> Alarm and stop	The action after the third maintenance expired.
32	User password	00000-65535( <b>07623</b> )	Change the password.
33	Battery charging start	8.0-30.0( <b>25.6V</b> )	When the battery voltage is lower than start value and remains 10s under non-running status, then the relay is opened. When it is higher than the close value and remains 10s, relay is closed. Once coming into running mode, there is no output.
34	Battery charging stop	10.0-36.0( <b>27.8V</b> )	
35	E.T.S. hold times	1-10( <b>2 times</b> )	The max E.T.S. hold on power shall be canceled once stop success under auto mode . the output interval time is " Fail to stop " .
36	ATS in manual mode	<b>Disable/Enable</b>	When it is set to enabled, when the generator set meets the closing conditions, it will be loaded automatically.

### 3)Delay time setting

NO	Parameter	Range( <b>default</b> )	Notes
1	Start delay	0-6500.0s( <b>5.0s</b> )	The time during the genset starts after the mains failure or remote signal is valid.
2	Preheat time	0-6500.0s( <b>0.0s</b> )	The time needed to be preheat before the starter on power.
3	Longest pre-oil supply	0-180.0s( <b>0.0s</b> )	Under pre-oil supply, if the oil pressure is higher than setting value, then pre-oil supply stopped.
4	Cranking time	3.0-60.0s( <b>8.0s</b> )	The time when the starter is on power.
5	Crank rest time	3.0-60.0s( <b>10.0s</b> )	If crank failure, the waiting time before the second test time.
6	Oil pressure delay	0-20.0s( <b>0.0s</b> )	When the crank condition contains oil pressure, if the oil pressure is higher than the preset value and continue for few seconds, then it is regarded as crank success.
7	Safety delay	1.0-60.0s( <b>8.0s</b> )	Low oil pressure, high water temperature, under speed, under frequency, under voltage, charge failure are all invalid during this time except for emergency stop and over speed.
8	Start idle time	0-3600.0s( <b>5.0s</b> )	Idle running time when crank successfully.
9	Longest RPM-up time	0-3600.0s( <b>120.0s</b> )	The longest speed-up time,during which time the system will exit once speed increased successfully .
10	Longest Temp.-up time	0-3600.0s( <b>0.0s</b> )	The longest warming-up time,during which time the system will exit once temperature increased successfully .
11	Longest Volt.-up time	0-3600.0s( <b>120.0s</b> )	The longest voltage-up time,during which time the system will exit once voltage increased successfully .
12	Warming-up time	0-3600.0s( <b>10.0s</b> )	The time needed for loading.

13	Back to Mains time	0-3600.0s <b>(10.0s)</b>	To avoid the switch actions if the mains unstable. If the remote start signal is invalid (DC7XD will check if the mains normal), genset will not switch immediately, after the delay time, it will transfer to mains. during the delay, if the remote start signal is valid, then genset will come into rated running.
14	Back to Gens time	0-3600.0s <b>(5.0s)</b>	There shall be loading delay from Mains to Gens if the remote start signal valid or Mains abnormal under Cooling time.
15	Cooling time	0-3600.0s <b>(30.0s)</b>	After unloading, the time of cooling down by radiator before stop. during the delay, if the remote start signal is valid, then genset will come into rated running.
16	Stop idle time	0-3600.0s <b>(5.0s)</b>	Idle-speed running time.
17	E.T.S. hold time	0-600.0s <b>(10.0s)</b>	Stop solenoid on power time.
18	Fail to stop	5-180.0s <b>(30.0s)</b>	If the RPM is 0 during the stop failure time, then the stop failure time is no needed.
19	Emergency delay	0-10.0s <b>(1.5s)</b>	Over speed and over frequency alarm delay.
20	Normal alarm delay	2.0-20.0s <b>(5.0s)</b>	The alarm delay except for over speed and over frequency
21	Normal warning delay	1.0-20.0s <b>(2.0s)</b>	The warning delay.
22	AC Voltage abnormal delay	2.0-20.0s <b>(10.0s)</b>	Over / under voltage delay.
23	Over current 【inverse time】	0.1-36.0 <b>(36.0)</b>	This option will not take effect until the <b>[31-Over phase current delay]</b> is set to 0. The overcurrent delay is inverse time, and the formula is $T=t/((IA/IT) - 1)^2$ .
24	Over power 【inverse time】	0.1-36.0 <b>(36.0)</b>	This option will not take effect until the <b>[32-Over total power delay]</b> is set to 0. The over power delay is inverse time, and the formula is $T=t/((IA/IT) - 1)^2$ .
25	Transfer switch delay	0-3600.0s <b>(5.0s)</b>	The time from Mains to Gens.
26	Load / unload pulse width	1.0-10.0s <b>(5.0s)</b>	Mains and Gens loading and unloading pulse width, when it is 10s, it is regarded as continuous output.
27	Choke close delay	0-200.0s <b>(3.0s)</b>	Choke close delay.
28	Pulse speed up delay	0.1 – 60.0s <b>(0.1s)</b>	The interval time of the pulse speed up relay change.
29	Pulse speed down delay	0.1 – 60.0s <b>(0.1s)</b>	The interval time of the pulse speed down relay change.
30	Standby battery charging time	10-600min <b>(600min)</b>	When the standby battery charged well, the power input will be stopped.
31	Over phase current delay	0-3600.0s <b>(30s)</b>	When this parameter is set to 0, the over current delay is the inverse time; if not, the over current delay is the time set for this parameter.

32	Over total power delay	0-3600.0s( <b>30s</b> )	When this parameter is set to 0, the over power delay is the inverse time; if not, the over current delay is the time set for this parameter.
33	Fuel output delay	0-60.0s( <b>2.0s</b> )	The output time of fuel valve relay before crank.

#### 4) Engine Alarm setting

NO	Parameter	Range (defaults)	Notes
1	Over speed warning	0-200% ( <b>107%</b> )	Rated RPM multiplying by this value is regarded as over speed warning value. When the RPM is higher than the warning value and comes into over speed delay but still higher, then over speed warns. If the value is set as 200, then the over speed alarm is disabled.
2	Over speed alarm	0-200% ( <b>114%</b> )	Rated RPM multiplying by this value is regarded as over speed alarm value. When the RPM is higher than the alarm value and comes into over speed delay but still higher (emergency faults delay), then over speed alarms. If the value is set as 200, then the over speed alarm is disabled.
3	Over speed revert	0-200% ( <b>108%</b> )	Rated RPM multiplying by this value is regarded as over speed alarm revert value.
4	Under speed warning	0-200% ( <b>90%</b> )	Rated RPM multiplying by this value is regarded as under speed warning value. When the RPM is lower than the warning value and comes into under speed delay but still lower (normal warning delay), then under speed warns. If the value is set as 0, then the over speed alarm is disabled.
5	Under speed alarm	0-200% ( <b>80%</b> )	Rated RPM multiplying by this value is regarded as under speed alarm value. When the RPM is lower than the alarm value and comes into under speed delay but still lower (normal faults delay), then under speed alarms. If the value is set as 0, then the under speed alarm is disabled.
6	Under speed revert	0-200% ( <b>85%</b> )	Rated RPM multiplying by this value is regarded as under speed alarm revert value.
7	Low oil pressure warning	0-999kpa ( <b>180kpa</b> )	When the oil pressure is lower than the value and comes into low oil pressure warning delay but still lower (normal warning delay), then low oil pressure warns. If it is higher than the value then warning clears. If the value is set as 0, then the low oil pressure warning is disabled.
8	Low oil pressure alarm	0-999kpa ( <b>103kpa</b> )	When the oil pressure is lower than the alarm value and comes into low oil pressure delay but still lower (normal faults delay), then low oil pressure alarms. If the value is set as 0, then the under speed alarm is disabled.
9	High water temperature warning	20-200°C ( <b>95°C</b> )	When the water temperature is higher than the value and comes into high temperature warning delay but still higher (normal warning delay), then high temperature warns. If it is lower than the value then warning clears. If the value is set as 200, then the high temperature warning is disabled.
10	High water temperature alarm	20-200°C ( <b>98°C</b> )	When the water temperature is higher than the alarm value and comes into high temperature delay but still higher (normal faults delay), then high temperature alarms. If the value is set as 200, then the high temperature alarm is disabled.

11	High oil temperature warning	20-200°C <b>(95 °C)</b>	When the temperature is higher than the value and comes into high temperature warning delay but still higher (normal warning delay), then high temperature warns. If it is lower than the value then warning clears. If the value is set as 200, then the high temperature warning is disabled.
12	High oil temperature alarm	20-200°C <b>(100 °C)</b>	When the temperature is higher than the alarm value and comes into high temperature delay but still higher (normal faults delay), then high temperature alarms. if the value is set as 200, then the high temperature alarm is disabled.
13	High cylinder temperature warning	20-200°C <b>(120 °C)</b>	When the temperature is higher than the value and comes into high temperature warning delay but still higher (normal warning delay), then high temperature warns. If it is lower than the value then warning clears. If the value is set as 200, then the high temperature warning is disabled.
14	High cylinder temperature alarm	20-200°C <b>(150 °C)</b>	When the temperature is higher than the alarm value and comes into high temperature delay but still higher (normal faults delay), then high temperature alarms. if the value is set as 200, then the high temperature alarm is disabled.
15	High genset box temperature warning	20-200°C <b>(65 °C)</b>	When the temperature is higher than the value and comes into high temperature warning delay but still higher (normal warning delay), then high temperature warns. If it is lower than the value then warning clears. If the value is set as 200, then the high temperature warning is disabled.
16	High genset box temperature alarm	20-200°C <b>(85 °C)</b>	When the temperature is higher than the alarm value and comes into high temperature delay but still higher (normal faults delay), then high temperature alarms. if the value is set as 200, then the high temperature alarm is disabled.
17	Low fuel level warning	0-100% <b>(20%)</b>	When the fuel level is lower than the value and comes into low fuel level warning delay but still lower (normal warning delay), then low fuel level warns. If it is higher than the value then warning clears. If the value is set as 0, then the low fuel level warning is disabled.
18	Low fuel level alarm	0-100% <b>(0%)</b>	When the fuel level is lower than the alarm value and comes into low fuel level delay but still lower (normal faults delay), then low fuel level alarms. if the value is set as 0, then the under speed alarm is disabled.
19	Over battery voltage warning	0-200% <b>(135%)</b>	Rated battery voltage multiplying by this value is regarded as over battery voltage warning value. When the battery input is higher than the warning value and comes into over battery voltage delay but still higher (normal faults delay), then over battery voltage warns. if the value is set as 200, then the over battery voltage is disabled.
20	Under battery voltage warning	0-200% <b>(100%)</b>	Rated battery voltage multiplying by this value is regarded as under battery voltage warn value. When the battery input is lower than the warning value and comes into under battery voltage delay but still lower (normal faults delay), then under battery voltage warns. if the value is set as 0, then the under battery voltage is disabled.
21	Charger	1.0-30.0V	When the gap between D+ and B+ is over than this

warning	<b>(30.0V)</b>	value, and there is charging failure but still high(normal warning delay), then charge failure warns. Once the gap is lower than the value, warns clear. If the value is set as 300, then the charge failure is disabled.
---------	----------------	---

### 5)Generator alarm parameters

NO	Parameter	Range(defaults)	Notes
1	Over freq warning	0-200%(110%)	Rated frequency multiplying by this value is regarded as under over frequency warn value. When the Freq is higher than the value and comes into over freq warning delay but still higher(normal warn delay), then over frequency warns. If it is lower than the value then warning clears. If the value is set as 200, then the warning is disabled.
2	Over freq alarm	0-200%(114%)	Rated frequency multiplying by this value is regarded as under over frequency alarm value. When the Freq is higher than the value and comes into over freq delay but still higher(emergency faults delay), then over frequency alarms.If the value is set as 200, then the alarm is disabled.
3	Over freq revert	0-200%(112%)	Rated frequency multiplying by this value is regarded as under over frequency revert value.
4	Under freq warning	0-200%(90%)	Rated frequency multiplying by this value is regarded as under under frequency warn value. When the Freq is lower than the value and comes into under freq delay but still lower(normal warn delay), then under frequency warns..If the value is set as 0, then the warning is disabled.
5	Under freq alarm	0-200%(80%)	Rated frequency multiplying by this value is regarded as under frequency alarm value. When the Freq is lower than the value and comes into under freq delay but still lower(normal faults delay), then under frequency alarms.If the value is set as 0, then the alarm is disabled.
6	Under freq revert	0-200%(85%)	Rated frequency multiplying by this value is regarded as under under frequency revert value.
7	Over voltage warning	0-200%(112%)	Rated voltage multiplying by this value is regarded as over voltage warn value. When the voltage is higher than the value and comes into over voltage delay but still higher(normal warn delay), then over voltage warns..If the value is set as 200, then the warning is disabled.
8	Over voltage alarm	0-200%(120%)	Rated voltage multiplying by this value is regarded as over voltage alarm value. When the voltage is higher than the value and comes into over voltage delay but still higher(normal faults delay), then over voltage alarms.If the value is set as 200, then the alarm is disabled.
9	Over voltage revert	0-200%(115%)	Rated voltage multiplying by this value is regarded as over voltage revert value.
10	Under voltage	0-200%(90%)	Rated voltage multiplying by this value is regarded



	warning		as under voltage warn value. When the voltage is lower than the value and comes into under voltage delay but still lower (normal warn delay), then under voltage warns.If the value is set as 0, then the warning is disabled.
11	Under voltage alarm	0-200% <b>(80%)</b>	Rated voltage multiplying by this value is regarded as under voltage alarm value. When the voltage is lower than the value and comes into under voltage delay but still lower(normal faults delay), then under voltage alarms.If the value is set as 0, then the alarm is disabled.
12	Under voltage revert	0-200% <b>(85%)</b>	Rated voltage multiplying by this value is regarded as under voltage revert value.
13	Phase current over-load warning	0-200% <b>(90%)</b>	Rated current multiplying by this value is regarded as over current warn value. When the phase current is higher than the value and comes into over current delay but still higher(normal warn delay), then over current warns..If the value is set as 200, then the warning is disabled.
14	Phase current over-load alarm	0-200% <b>(100%)</b>	Rated current multiplying by this value is regarded as over current alarm value. When the current is higher than the value and comes into over current delay but still higher(over current faults delay), then over current alarms.If the value is set as 200, then the alarm is disabled.
15	Phase current over-load revert	0-200% <b>(95%)</b>	Rated current multiplying by this value is regarded as over current revert value.
16	Non-balance current ratio warning	10-100% <b>(100%)</b>	It is valid for 2P3W or 3P4W.When the non-balance current ratio is higher than the value and comes into delay but still higher(normal warn delay), then non-balance current ratio warns.If the value is set as 100, then the warning is disabled.
17	Non-balance current ratio alarm	10-100% <b>(100%)</b>	It is valid for 2P3W or 3P4W. When the non-balance current ratio is higher than the value and comes into delay but still higher(normal faults delay), then non-balance current ratio warns.If the value is set as 100, then the alarm is disabled.
18	Non-balance current ratio revert	10-100% <b>(100%)</b>	
19	Over total power warning	0-200% <b>(90%)</b>	Rated power multiplying by this value is regarded as over power warn value. When the loading power is higher than the value and comes into delay but still higher(normal warn delay), then over power warns..If the value is set as 200, then the warning is disabled.
20	Over total power alarm	0-200% <b>(100%)</b>	Rated power multiplying by this value is regarded as over power alarm value. When the loading power is higher than the value and comes into delay but still higher(power faults delay), then over power alarms..If the value is set as 200, then the alarm is disabled.

21	Over total power revert	0-200%(95%)	Rated power multiplying by this value is regarded as over power revert value.
----	-------------------------	-------------	---

**6)Output/input setting**

NO	Parameter	Range(defaults)	Notes
1	AUX. OUTPUT 1 (Functional of PIN 6)	0-71 ( <b>25. E.S.T. hold</b> )	<b>0.Disable.</b> <b>1.Public warning output:</b> when there is any warning output.
2	AUX. OUTPUT 2 (Functional of PIN 7,8,9)	0-71 ( <b>15.Idle speed control</b> )	<b>2.Public alarm output:</b> when there is any alarm output, alarm locks till revert back.
3	AUX. OUTPUT 3 (Functional of PIN 10,11)	0-71 ( <b>21.Gens loading</b> )	<b>3.Audio alarm:</b> when there is any alarm output, the Audio controls. <b>4.Shades control:</b> there is output once genset starts and stop till stable.
4	AUX. OUTPUT 4 (Functional of PIN 12,13)	0-71 ( <b>43.Mains loading</b> )	<b>5.Preheat mode 1:</b> preheat before start.
5	AUX. OUTPUT 5 (Functional of PIN E4,E5,E6)	0-71 ( <b>2.Public alarm output</b> )	<b>6.Preheat mode 2:</b> preheat before crank success. <b>7.Preheat mode 3:</b> preheat after safety delay. <b>8.Preheat mode 4:</b> preheat till temperature-up end. <b>9.Preheat mode 5:</b> preheat till temperature-up end, but no preheat when motor starts. <b>10.Choke control:</b> choke will be started after crank success and off after delay. <b>11.Pre-oil supply control:</b> Under pre-oil supply,if the oil pressure is higher than setting value or pre-oil supply time ends, then pre-oil supply stopped. <b>12.Fuel output:</b> output once gens starts and off till stable. <b>13.Crank output:</b> output once cranking, no output in other mode. <b>14.Genset running:</b> output under running,off once RPM is lower than cranking RPM. The crank success condition can be set. <b>15.Idle speed control 1:</b> used for speed controller, there is output under idle but no output under high speed. <b>16.Speed-up control:</b> there is output when coming into high speed warming up, which time is <b>Longest RPM-up time.</b> <b>17.High speed control:</b> The output is valid after idle delay is completed, and the output is closed after high-speed heat dissipation.

		<p><b>18.Excitation output:</b> there is output during cranking procession and there is 2s output if there is no frequency under high speed status.</p> <p><b>19.Rated running:</b> there is output under rated running.</p> <p><b>20.Gens valid:</b> when there is voltage output between low voltage alarm revert value and high voltage alarm revert value, among which there is no output.</p> <p><b>21.Gens load:</b> continuous or pulse type according to time setting.</p> <p><b>22.Gens unload:</b> continuous or pulse type according to time setting.</p> <p><b>23.Public un/loading:</b> Continuous output during power generation closing and disconnection during opening.</p> <p><b>24.Speed-down control:</b> the output time is shutdown idle delay during shutdown idle or shutdown on power procession.</p> <p><b>25.E.S.T. hold:</b> shutdown output, it is used for gens with stop solenoid. when the setting value of shutdown delay is over, then it is off.</p> <p><b>26.System in stop:</b> there is output under stop mode.</p> <p><b>27.System in manual:</b> there is output under manual mode.</p> <p><b>28.System in test:</b> there is output under test mode(not for DC70D).</p> <p><b>29.System in auto:</b> there is output under auto mode.</p> <p><b>30.Output for AUX1:</b>when the switch value 1 is set as high level active relay or low level active relay, there is output or shutdown according to the input status.</p> <p><b>31.Output for AUX2:</b>when the switch value 1 is set as high level active relay or low level active relay, there is output or shutdown according to the input status.</p> <p><b>32.Output for AUX3:</b>when the switch value 1 is set as high level active relay or low level active relay, there is output or shutdown according to the input status.</p> <p><b>33.Output for AUX4:</b>when the switch value 1 is set as high level active relay or low level active relay, there is output</p>
--	--	---

		<p>or shutdown according to the input status.</p> <p><b>34.Output for AUX5:</b>when the switch value 1 is set as high level active relay or low level active relay, there is output or shutdown according to the input status.</p> <p><b>35.High water temperature output:</b> there is output if the water temperature is higher than start condition and shutdown if it is lower than the shutdown condition.</p> <p><b>36.High oil temperature output:</b> there is output if the oil temperature is higher than start condition and shutdown if it is lower than the shutdown condition.</p> <p><b>37.High cylinder temperature output:</b> there is output if the cylinder temperature is higher than start condition and shutdown if it is lower than the shutdown condition.</p> <p><b>38.High genset box temperature output:</b> there is output if the genset box temperature is higher than start condition and shutdown if it is lower than the shutdown condition.</p> <p><b>39.Fuel pump output:</b> there is output if the oil capacity is lower than start condition for 10s and shutdown if it is higher than the shutdown condition for 1s.</p> <p><b>40.Battery charging control:</b> there is output if the voltage is lower than the preset value under standby status and shutdown after start and in running status.</p> <p><b>41.Mains abnormal:</b> there is output when the mains voltage is lower than low voltage threshold and higher than high voltage threshold during mains abnormal delay time. There is not output when the mains voltage is higher than low voltage revert threshold or lower than high voltage revert threshold during mains normal delay time. This is not for DC70D.</p> <p><b>42.Mains normal:</b> there is output when the mains voltage is higher than low voltage threshold and lower than high voltage threshold during mains normal delay time. There is not output when the</p>
--	--	---

		<p>mains voltage is lower than low voltage revert threshold or higher than high voltage revert threshold during mains abnormal delay time. This is not for DC70D.</p> <p><b>43.Mains loading:</b> continuous or pulse type according to time setting. Not for DC70D.</p> <p><b>44.Mains unloading:</b> continuous or pulse type according to time setting. Not for DC70D .</p> <p><b>45.ECU power:</b> apply to electrical ECU engine,used for control ECU power.</p> <p><b>46.ECU stop:</b> apply to electrical ECU engine,used for control ECU shutdown.</p> <p><b>47.ECU warning:</b> there is a warn signal from ECU.</p> <p><b>48.ECU alarm:</b> there is an alarm signal from ECU.</p> <p><b>49.ECU communication failure:</b> Cannot communicate with ECU.</p> <p><b>50. Pulse speed up output:</b>the pulse shall be sent out in the interval of “<b>Pulse speed up delay</b>” under speed – up.</p> <p><b>51. Pulse speed down output:</b> the pulse shall be sent out in the interval of “<b>Pulse speed down delay</b>” under stop idle speed.</p> <p><b>52. Over speed output:</b> the relay shall output after overspeed/over frequency alarms.</p> <p><b>53. Low oil pressure alarm:</b> the relay shall output after low oil pressure sensor/switch alarms.</p> <p><b>54. High water temperature alarm:</b> the relay shall output after high water temperature sensor/switch alarms.</p> <p><b>55. High oil temperature alarm:</b> the relay shall output after high oil temperature sensor/switch alarms</p> <p><b>56.Idle speed control 2:</b> used for speed controller, there is output under idle but no output under high speed.</p> <p><b>57.Oil pump control:</b> when the CAN protocol is Yuchai LMB. When the genset is in the standby state, the oil pump controls the output every 30 minutes. If the oil pressure is higher than 100kPa or the output is 1 minute</p>
--	--	--

			<p>(whichever comes first), the oil pump control output will stop; when the genset is in the preheating state, the oil pump control will always output.</p> <p><b>58.Public unload:</b> Public unload of Gens and Mains.</p> <p><b>59. Underspeed alarm:</b> Action when underspeed alarm.</p> <p><b>60. Low fuel level warn:</b> Action when low fuel level warning.</p> <p><b>61. Low fuel level alarm:</b> Action when low fuel level alarm.</p> <p><b>62. Under freq alarm:</b> Action when under frequency alarm.</p> <p><b>63. Over voltage alarm:</b> Action when over-voltage alarm.</p> <p><b>64. Under voltage alarm:</b> Action when undervoltage alarm.</p> <p><b>65. Over-current alarm:</b> Action when over-current alarm.</p> <p><b>66. Non-balance current ratio alarm:</b>Output when non-balance current ratio alarm.</p> <p><b>67.Overpower alarm:</b> Action when over power alarm.</p> <p><b>68. Emergency stop:</b> Action when emergency stop alarm.</p> <p><b>69. STOP failure:</b> Action when shutdown failure alarm.</p> <p><b>70. High battery volt:</b> Action when the battery voltage is too high warning.</p> <p><b>71. Low battery volt:</b> Action when the battery voltage is too low warning.</p>
6	AUX. INPUT 1 (Functional of PIN 20)	0-44( <b>2.High water temperature alarm</b> )	<b>0.Disable.</b>
7	AUX. INPUT 2 (Functional of PIN 21)	0-44 ( <b>Low oil pressure switch</b> )	<b>1.Low oil pressure alarm switch.</b>
8	AUX. INPUT 3 (Functional of PIN 22)	0-44 ( <b>33.Remote start</b> )	<b>2.High water temperature alarm switch.</b>
9	AUX. INPUT 4 (Functional of PIN 38)	0-44 ( <b>8.Low Fuel level warning input</b> )	<b>3.High oil temperature alarm switch.</b>
10	AUX. INPUT 5 (Functional of PIN 39)	0-44 ( <b>6.Low water level alarm input</b> )	<b>4.High cylinder temperature alarm switch.</b>
			<b>5.High genset box temperature alarm switch.</b>
			<b>6.Low water level warning switch.</b>
			<b>7.Low water level alarm switch.</b>
			<b>8.Low fuel level warning input.</b>
			<b>9.Low fuel level alarm input.</b>
			<b>10.Low engine oil level warning input.</b>
			<b>11.Low engine oil level alarm input.</b>
			<b>12.Charging failure warning:</b> output when charging failure.

		<p><b>13.Low oil pressure shutdown disabled:</b> valid if there is signal input.</p> <p><b>14.High water temperature shutdown disabled:</b> valid if there is signal input.</p> <p><b>15.High oil temperature shutdown disabled:</b> valid if there is signal input.</p> <p><b>16. High cylinder temperature shutdown disabled:</b> valid if there is signal input</p> <p><b>17. High genset box temperature shutdown disabled:</b> valid if there is signal input.</p> <p><b>18.External instant warning input.</b></p> <p><b>19.External instant alarm input.</b></p> <p><b>20.External instant unloading shutdown disabled:</b> the gens loading will transfer unloading if there is signal input.</p> <p><b>21.External instant unloading shutdown:</b> the gens loading will transfer unloading and shutdown.</p> <p><b>22.Gens un/loading input:</b> connect to the gens loading switchs auxiliary point.</p> <p><b>23.Mains un/loading input:</b> connect to auxiliary point of mains loading switch.(not for DC72D).</p> <p><b>24.Louver status input.</b></p> <p><b>25.Auto start disabled:</b> gens will not start if there is signal input whatever mains normal or not.</p> <p><b>26.Auto stop disabled:</b> gens will not stop if there is signal input whatever mains normal or not.</p> <p><b>27.V+ active relay.</b></p> <p><b>28.V- active relay.</b></p> <p><b>29.Stop by radiator if high temperature:</b>The controller will shutdown the gens after high speed cooling down delay when temperature is too high if this signal is valid and gens under normal running . the controller will shutdown the gens directly if the signal is not valid.</p> <p><b>30.Stop by radiator if high oil temperature:</b>The controller will shutdown the gens after high speed cooling down delay when temperature is too high if this signal is valid and gens under normal running . the controller will shutdown the gens directly if the signal is not valid.</p>
--	--	--

			<p><b>31. Stop by radiator if high cylinder temperature:</b> The controller will shutdown the gens after high speed cooling down delay when temperature is too high if this signal is valid and gens under normal running . the controller will shutdown the gens directly if the signal is not valid.</p> <p><b>32. Stop by radiator if high genset box temperature:</b> The controller will shutdown the gens after high speed cooling down delay when temperature is too high if this signal is valid and gens under normal running . the controller will shutdown the gens directly if the signal is not valid.</p> <p><b>33. Remote start(with load):</b> the gens comes into start procession if this signal is valid and under auto mode, Closing with load.</p> <p><b>34. Soundproof alarm:</b> audio alarm output is disabled if there is signal output.</p> <p><b>35. Front face button disabled:</b> any button except for page button is disabled if there is signal output.</p> <p><b>36. Meter mode:</b> all output are disabled, alarm and warns are invalid. any button except for page button is disabled.</p> <p><b>37. Remote control mode:</b> any button except for page button is disabled if the input is valid, LCD will display remote mode. remote control module can start/stop and monitor parameters through front face buttons.</p> <p><b>38. Simulate STOP.</b></p> <p><b>39. Simulate MANUAL.</b></p> <p><b>40. Simulate AUTO.</b></p> <p><b>41. Simulate START.</b></p> <p><b>42. Simulation GENS Close/Open.</b></p> <p><b>43. Simulation MAINS Close/Open.</b></p> <p><b>44. Remote start(without load):</b> the gens comes into start procession if this signal is valid and under auto mode, No closing with load.</p>
11	AUX. SENSOR 1 (Functional of PIN 17)	0-6( <b>2. Water temperature sensor</b> )	<p><b>0. Disable.</b></p> <p><b>1. Oil pressure.</b></p> <p><b>2. Water temperature.</b></p>
12	AUX. SENSOR 2 (Functional of PIN 18)	0-6 ( <b>1. Oil pressure sensor</b> )	<p><b>3. Oil temperature.</b></p> <p><b>4. Cylinder temperature.</b></p> <p><b>5. Genset box temperature.</b></p>



13	AUX. SENSOR 3 (Functional of PIN 19)	0-6( <b>0.Disable</b> )	<b>6. Fuel level.</b>  <b>Note: every sensor input can be set as same function.(oil pressure, fuel level warns and alarm will be judged according to the lowest value. Water temperature, oil temperature, cylinder temperature, genset box temperature warns and alarm will be judged by the highest value. Either of the inputs for alarm opened.)</b>
14	AUX. SENSOR 4 (Functional of PIN E1)	0-6( <b>0.Disable</b> )	
15	Oil pressure sensor	1:User defined-Resistance 2:User defined-Voltage 3:Volt In 1MPa-0-5V 4:Volt In 1MPa-0.5-4.5V <b>5:VDO 0-10Bar</b> 6:MEBAY-003B 7:SGH 8:SGD 9:SGX 10:CURTIS 11:DATCON 10Bar 12:VOLVO-EC 13:3015237 14:WEICHA1 0-0.6MPa 15:GENCON 0-10Bar	Choose the usual oil pressure sensor, if the sensor users choose is not these types, it can be User-defined. <b>The voltage type oil pressure sensor is only valid for "configurable sensor input 2" (pin 18).</b>
16	Coolant temperature sensor	1.User-defined <b>2.VDO 40-120 °C</b> 3.MEBAY-001B 4.SGH 5.SGD 6.SGX 7.CURTIS 8.DATCON 9.VOLVO-EC 10.3015238 11.PT100 12.MEBAY-Mier 13.WEICHA1 40-120°C 14.GENCON 40-120°C	Choose the usual water temperature sensor, if the sensor users choose is not these types, it can be User-defined.
17	Oil temperature sensor	1.User-defined <b>2.VDO 40-120 °C</b> 3.MEBAY-001B 4.SGH 5.SGD 6.SGX 7.CURTIS 8.DATCON 9.VOLVO-EC	Choose the usual oil temperature sensor, if the sensor users choose is not these types, it can be User-defined.

		10.3015238 11.PT100 12.MEBAY-Mier 13.WEICHAI 40-120°C 14.GENCON 40-120°C	
18	Cylinder temperature sensor	1.User-defined 2.MEBAY-Mier <b>3.PT100</b> 4-15: Reserved	If the sensor users choose is not these types, it can be User-defined.
19	Genset box temperature sensor	1.User-defined 2.MEBAY-Mier <b>3.PT100</b> 4-15: Reserved	If the sensor users choose is not these types, it can be User-defined.
20	Fuel level sensor	1.User-defined 2.0-100Ω 3.100-0Ω 4.0-107Ω 5.107-0Ω <b>6.0-180Ω</b> 7.180-0Ω 8.180-10Ω 9.10-180Ω 10.120-10Ω 11.10-120Ω 12.90-0Ω 13.0-90Ω 14.0-30Ω 15.73-10Ω 16.240-33Ω 17.33-100Ω 18.0-200Ω 19.200-0Ω	If the sensor users choose is not these types, it can be User-defined.
21	AUX. INPUT 1 valid	<b>0- Normal close</b> 1- Normal open	The status of switch value input valid.
22	AUX. INPUT 2 valid	<b>0- Normal close</b> 1- Normal open	
23	AUX. INPUT 3 valid	<b>0- Normal close</b> 1- Normal open	
24	AUX. INPUT 4 valid	<b>0- Normal close</b> 1- Normal open	
25	AUX. INPUT 5 valid	<b>0- Normal close</b> 1- Normal open	

### 7) Working plan and maintenance setting

NO	Parameter	Range(defaults)	Notes
1	Working plan format	<b>Disable</b> Every month Every week	This mode must be under auto mode. Working plan is disabled once setting as disable. The working plan will be executed according the chosen date when setting as every month.

			The working plan will be executed according to the chosen date when setting as every week.
2	Maintenance date per month	From 1 <sup>st</sup> to 31 <sup>st</sup> <b>Default: the first day</b>	The date chosen for every month.
3	Maintenance date per week	Monday to Sunday <b>Default: Sunday</b>	The date chosen for every week.
4	Maintenance with load or not	<b>Disabled</b> /with load	To choose if the genset starts with load or not.
5	Maintenance start time	00:00-23:59( <b>00:00</b> )	Maintenance start time setting.
6	Maintenance running time	1-120m( <b>5m</b> )	Maintenance running time setting.

### 8) Mains protection

No	Parameter	Range(defaults)	Notes
1	Phase	<b>Disable(70D)</b> 1 Phase 2 Wire 2 Phase 3 Wire 3 Phase 3 Wire <b>3 Phase 4 Wire(72D)</b>	Choose the input, there is no display if setting as disable.
2	Mains under volt	55-330V( <b>184V</b> )	When the mains voltage is lower than the "low voltage crank threshold" and comes into mains low voltage delay(normal failure delay) but still lower, then mains becomes invalid. If the voltage become higher than "low voltage revert threshold" during normal failure delay time, then it will not alarm.
3	Revert under volt	55-40000V( <b>207V</b> )	
4	Mains over volt	55-40000V( <b>276V</b> )	
5	Revert over volt	55-40000V( <b>253V</b> )	When the mains voltage is higher than the "high voltage crank threshold" and comes into mains high voltage delay(normal failure delay) but still higher, then mains becomes invalid. If the voltage become lower than "low voltage revert threshold" during normal failure delay time, then it will not alarm.
6	Mains normal delay	0.0-3600.0S( <b>10.0s</b> )	The time from abnormal to normal, which is used for ATS transfer.
7	Mains abnormal delay	0.0-3600.0S( <b>5.0s</b> )	
8	Loss of Phase judgment	<b>Loss of Phase 1</b> <b>Loss of Phase 2</b> <b>Loss of Phase 3</b>	Set the phase loss condition to judge whether the mains is abnormal.

### 9) LCD setting

No	Parameter	Range(defaults)	Notes
1	Start screen display time	0-20.0s( <b>5.0s</b> )	Start screen display time,0: No-display.
2	Lightness of LCD	20-100%( <b>50%</b> )	Lightness adjustment.
3	LCD comparison	20-100%( <b>100%</b> )	LCD comparison adjustment.
4	Back lightness	20-100%( <b>80%</b> )	Back lightness adjustment.

5	Saving mode	5.0-200.0s( <b>200.0s</b> )	LCD light will be closed automatically without any button pressed after delay.If setting as 200.0s, back light always lighted.
6	Homing display	5.0-600.0s( <b>60.0s</b> )	The time when the page reverts back to the home page .If setting as 600.0s:disabled.
7	LOGO delay display under standby	5.0-6000.0( <b>6000.0s</b> )	Start screen will be opened without any button pressed after delay.If setting as 6000.0s: disabled.
8	ECU page	Disable/ <b>Enable</b>	Set whether the ECU page is displayed.
9	Display UI selection	Dark mode <b>Bright mode</b>	Set the default display mode of the display interface after the controller is powered on.

### 10)USB/485 PORT

No	Parameter	Range( <b>default</b> )	Notes
1	Controller ID	1-255( <b>16</b> )	The IP built by controller and PC.
2	485 baud rate	0-4800 1-9600 <b>2-19200</b> 3-38400 4-57600 5-115200	RS485 communication baud rate selection.
3	485 CRC setting	0-CRC L_H <b>1-CRC H_L</b>	Sequence selection of RS485 communication protocol CRC;
4	Controller working mode	<b>Host mode</b> Slave mode	Slave mode can read and display parameters of slave controller through RS485 port.

### 11)CAN communication

NO	Parameter	Range( <b>default</b> )	Notes
1	CAN failure	Warn/ Alarm/ <b>Disable</b>	ECU communication failure.
2	CAN Protocol	<b>0- Disabled</b> 1:J1939 2:Cummins ISB 3:Cummins-CM850 4:Cummins QSX15-CM570 5:Cummins-CM850-PCC13X 6:Cummins-DCEC-QSZ13 7:Cummins-CCEC-QSN 8:Perkins 9:Perkins-1100 10:Volvo 11:Volvo-EMS2 12:Volvo-EMS2b 13:Volvo-EDC4 14:Scania 15:Scania-kw2000 16:Scania-kw2k-coo 17:John Deere 18:mtu-ADEC 19:mtu-ADEC-SAM 20:mtu-ADEC-303 21:mtu-ADEC-304 22:BOSCH	CAN protocol Option : the Engine parameters like RPM, oil pressure, water temperature are all from ECU data after choosing the relative protocol.

		23:GTSC1 24:MTSC1 25:YUCHAI-YCECU 26:Y&C ENGINE-YC6K 27:WEICHAI-WISE15 28:CHANGCHAI-ECU15 29:YUCHAI-LMB 30:MAN 31:J1939-C 32:SDEC-H/D 33:SDEC-E 34:YTO 35:DEUTZ EMR2-2001 36:DEUTZ EMR2-2012 37:DEUTZ EMR3 38:DEUTZ EMR4 39:NEVED-ECU13 40:Cummins-CM2150	
3	ECU warning	Disable/ <b>Enable</b>	ECU warnings enable.
4	ECU alarm	Disable/ <b>Enable</b>	ECU alarms enable.
5	Mask SPN	00000000	Up to 12 sets of alarm codes can be input, and the controller will not respond to the input alarm codes.
6	ECU idle	500-3000RPM <b>(750RPM)</b>	Set the speed when idling. Only the ECU that supports speed control is effective.
7	Slow speed up delay	0-120S <b>(5S)</b>	Through CAN port, it controls the time delay from idle speed up to rated speed. Only ECU supporting speed control is effective.
8	ECU speed control address	0-255 <b>(3)</b>	The TSC1 message ID address sent by the controller to the ECU, and the communication protocol must be 31: j1939-c.
9	CAN Baud Rate	<b>0-250kbps</b> 1-500kbps	Set the baud rate of CAN bus communication.

### 12)working plan

No	Parameter	Range(default)	Notes
1	Working plan	<b>Disable</b> Enable 1:remote start Enable 2:mains failure Enable 3:the above 1 or 2 Enable 4:running always	Working plan start condition.
2	Start time	00:00-23:59	The start time allowed.
3	End time	00:00-23:59	The end time allowed(the next day is valid).
4	Dates	1-31	Multiple choices according to the reality. The longest running time is 24 hours.

### 13)Data/time setting

No	Parameter	Range(defaults)	Notes
1	Date/Time	2016/01/01-	Permanent calendar inside, please correct the

		2099/12/31	time timely.
2	Current time	00:00:00-23:59:59	Permanent calendar inside, please correct the time timely.

#### 14)Self-define curve

NO	Parameter	Notes
1	Self-define oil pressure resistance curve	<b>Sensor curve can be User-defined by panel buttons, resistance and according value should be input,MAX 15 groups ,MIN 2 groups.</b>  <b>Rule: resistance should be input from small to large.</b>
2	Self-define oil pressure voltage curve	
3	Self-define water temperature curve	
4	Self-define oil temperature curve	
5	Self-define cylinder temperature curve	
6	Self-define genset box temperature curve	
7	Self-define fuel level curve	

## 12. Fault finding

Symptoms	Possible Solutions
Controller no response with power	Check DC voltage. Check DC fuse. Check if the terminal 1 and 2 is with battery voltage.
Genset shutdown	Check the water/cylinder temperature is too high or not. Check the genset AC voltage. Check DC fuse.
Genset Emergency Stop	Check the emergency stop button. Check that the voltage of the controller's 3 feet to the ground should be the battery voltage. Check the controller connection.
Low oil pressure alarm	Check oil pressure sensor and its wiring. Check the oil pressure sensor type and controller settings must be consistent. Check whether the low oil pressure sensor is normal.
High temperature alarm	Check temperature sensor and its wiring. Check the temperature sensor type and controller settings must be consistent. Check whether the temperature sensor is normal.
Shutdown Alarm in running	Check related switch and its connections according to the information on LCD. Check AUX. INPUTs.
Fail to start	Check fuel return circuit and wiring. Check start battery. Consult engine manual.
Starter motor does not respond	Check the wiring to the starter. Check start battery.
Unit operation but ATS does not switch	Check the ATS. Check the cable between the controller and the ATS.
USB communication is abnormal	Check the USB connection. Check whether the USB port of the computer is normal. Check whether the USB driver is installed.
RS485 cannot communicate normally	Check the connection. Check if the communication ID number setting is correct. Check if the A and B lines of RS485 are reversed.

<p>Check if the RS485 communication line driver is installed or not.          Check if the communication port of the PC is damaged.          Add a 120 <math>\Omega</math> resistor between the AB of the controller RS485.</p>
---