

# FC70DR FIRE PUMP CONTROLLER

## USER MANUAL



## Software Version

No.	Version	Date	Note
1	V1.0	2022-02-10	Original release.



Chongqing Mebay Technology Co.,Ltd

Add: No6-2,Building 4, Gangan Rd, Jiangbei District, Chongqing.

Tel: +86-23-6869 3061



Fax: +86-23-6765 8207

Web: <http://www.mebay.cn>

<http://www.cqmb.cn>

E\_mail: [sales@mebay.cn](mailto:sales@mebay.cn)

Symbol Description

Symbol	Description
 Note	Remind operators to operate correctly, otherwise it may cause the equipment not to work correctly.
 Be care	It is indicated that potential hazards can damage equipment without proper precautions.
 Warning	It is indicated if appropriate preventive measures are not taken, potentially dangerous situations may result in death, serious personal injury or significant property losses.



### Warning

- 1.The installation of this equipment must be carried out by professionals.
- 2.When installing and operating the controller, please read the entire instruction manual first.
- 3.Any maintenance and commissioning of the equipment must be familiar with all the equipment.
- 4.Safety standards and precautions in advance, otherwise it may cause personal injury or damage to related equipment.
- 5.After the installation of the controller is completed, please verify that all protection functions are valid.



### Be Care

- 1.Please keep the good connection of the power supply of the controller. Do not share the connection lines of the positive and negative electrodes of the battery with the floating charger.
- 2.During the operation of the engine, do not disconnect the battery, otherwise it may cause damage to the controller.

## Catalogue

Summary .....	6
Main Features .....	6
Parameters Display .....	7
Protection .....	7
Parameters .....	8
Overall Dimension and Wiring Diagram .....	9
Installation instruction .....	12
Panel and display .....	13
Key Function Description .....	13
Warnings and Shutdown Alarms .....	17
Parameter setting .....	25
Fault finding .....	38

### Notes:

1. All rights reserved. No part of this duplication may be reproduced in any material form (including photocopying or storing in any medium by electronic means or others) without the written permission of the copyright holder.
2. MEBAY Technology reserves the rights to change the contents of this document without prior notice.

## Summary

This controller is used for fire pump units driven by diesel engines, which has the functions of parameter setting, start, stop, parameter monitoring, fault monitoring and protection.

4.3 inch LCD screen display with brand new UI design is adapted in this controller can display related parameters directly. The LCD screen can display various faults at the same time. Once the unit does not run normally, it can effectively achieve protection.

There are Chinese/English interface options, more language can be set according to user's request. All the parameters can be configured through the front face buttons or use programmable interface by RS485 or USB to adjust via PC.

## Main Features

- ◆ 32bit high performance single chip microcomputer.
- ◆ 4.3 inch LCD screen, Available in Chinese/English languages, user's language set if necessary.
- ◆ Indicator and number display through UI surface.
- ◆ Acrylic material is adapted to protect the screen.
- ◆ Silicone panels, waterproof, oil-proof, UV-resistant, good operation feel and long service life.
- ◆ USB Port: parameters can be set even without power through USB port to monitor in real time.
- ◆ With RS485 communication port, can achieve "Three Remote" functions via MODBUS protocol.
- ◆ Standard CAN communication port, built-in J1939 protocol.
- ◆ Various kinds of parameters display.
- ◆ Input/output function, status can be shown directly.
- ◆ More categories of surface setting.
- ◆ Real time clock inside: preset time operate and auto maintenance is available. Genset working plan can be set as per week or month.
- ◆ Three class protection countdown function, which can set the maintenance time or date.
- ◆ The black box function can save the relevant parameters of the unit when the fault alarm occurs in real time, and it is convenient to find the cause of the fault.
- ◆ Totally 11 relay's output, among which 7 relay output can be self-configurable, each relay can be set as max 50 functions.
- ◆ With 6 switches input, up to 40 functions optional.
- ◆ 4 sensor simulation input connectors, 4 input types is configurable and various kinds of units can be set.
- ◆ 2 voltage sampling points of battery packs and 1 voltage sampling points of battery charger.
- ◆ 2 battery packs can be switched to start the unit.
- ◆ Battery charging control function, which can protect the battery according to battery voltage status.

- ◆ Sensor can be self-defined by front face button or PC software.
- ◆ Various of crank conditions (RPM, External input , Oil Pressure,) can be chosen.
- ◆ Control Protection: Auto Start/Stop of unit, perfect failure display and protection.
- ◆ Standard water-proof rubber gasket. The waterproof can reach IP65.
- ◆ Module design: All the connections are adapted with European connectors so that installation, connection, repair and replacement can be more easily.

### Parameters Display

- ◆ Engine RPM
- ◆ Engine oil pressure
- ◆ Engine water temperature
- ◆ Engine fuel level
- ◆ Engine battery voltage 1
- ◆ Engine battery voltage 2
- ◆ Raw water temperature
- ◆ Charging voltage
- ◆ Total Crank times
- ◆ Current running time
- ◆ Total running time
- ◆ Maintenance notice
- ◆ 6 switches input status display
- ◆ Output status display of 11 relays

### Protection

- ◆ Over speed
- ◆ Under speed
- ◆ RPM Lost
- ◆ Low oil pressure
- ◆ High Engine water temperature
- ◆ Low Engine water temperature
- ◆ Low fuel level
- ◆ High raw water temperature
- ◆ Low raw water temperature
- ◆ External real-time alarm
- ◆ Sensor Open
- ◆ Primary\Secondary \Third maintenance expire
- ◆ ECU alarm failure
- ◆ ECU communication Failure
- ◆ Low water level alarm
- ◆ Crank failure
- ◆ Stop Failure
- ◆ Over battery voltage
- ◆ Under battery voltage

**Parameters**

Options	Parameters
Working voltage	DC 8V----36V Continuous
Power consumption	Working: MAX 3W (Standby: MAX 2W)
MAX Accumulating Time	99999.9Hours (Min Store time:6min)
Rotate speed sensor Frequency	0-10000Hz
Fuel Relay Output	Max 16Amp Non-contact normally Open output
Crank 1 start Relay Output	Max 16Amp Non-contact normally Open output
Crank 2 start Relay Output	Max 16Amp Non-contact normally Open output
AUX. OUTPUT 1-2	Max 5Amp DC+VE Supply voltage
AUX. OUTPUT 3-7	250V/5 AMP Non-contact normally Open output
AUX. OUTPUT 8	250V/5 AMP Non-contact normally Open/Closed output
Sensor INPUT	4 fixed sensors
Excitation output	DC+VE supply voltage
AUX.INPUT 1-6	Available if connecting with Battery -
Working condition	-25-65°C
Storage condition	-40-85°C
Protection Level	IP65: when waterproof rubber gasket is added between controller and its panel
Insulation strength	Apply AC 2.2kV voltage between high voltage terminal and low voltage terminal; The leakage current is not more than 3mA within 1min.
Overall dimension	210mm*160mm*50mm
Panel cutout	186*142mm
Weight	0.7Kg



**Overall Dimension and Wiring Diagram**

◆ Overall Dimension:

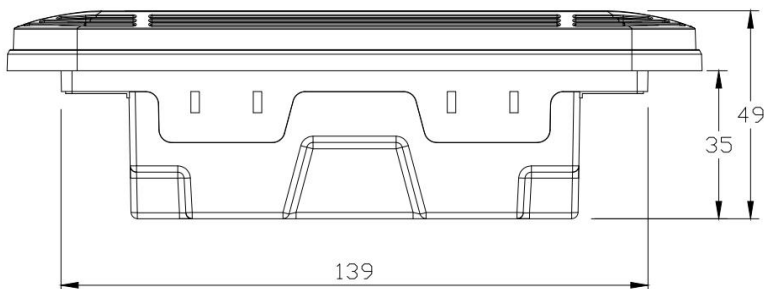
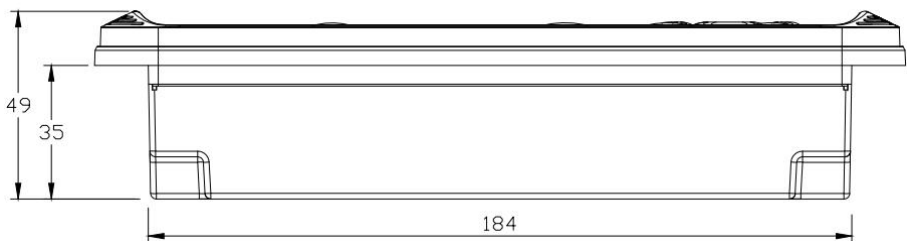

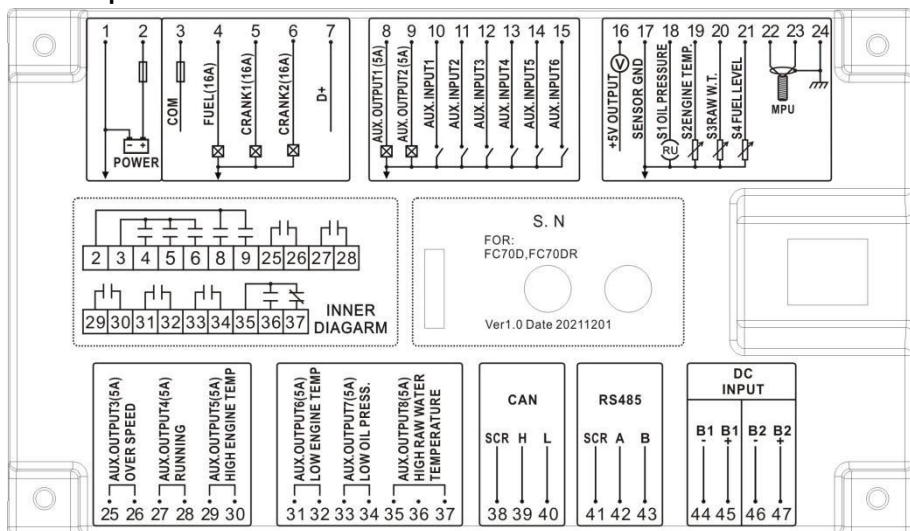
**◆ Descriptions of terminal connection**

No.	Function	Description	Cable cross sectional area
1	Battery Negative Input B-	Controller power supply input B-.	2.5mm <sup>2</sup>
2	Battery Negative Input B+	Controller power supply input B+.	2.5mm <sup>2</sup>
3	COM Relay Common Port	Relay output common port of No.4, No.5 and No.6.	2.5mm <sup>2</sup>
4	Fuel Output	Non-contact normally opened output, Max 16Amp.	2.5mm <sup>2</sup>
5	Crank 1 Output	Non-contact normally opened output, Max 16Amp.	2.5mm <sup>2</sup>
6	Crank 2 Output	Non-contact normally opened output, Max 16Amp.	2.5mm <sup>2</sup>
7	Charger D+ output	Active output, Connected with D+(W/L) terminal of charger.	1.0mm <sup>2</sup>
8	Aux. Output 1	Active output, Max 5Amp.	1.5mm <sup>2</sup>
9	Aux. Output 2	Active output, Max 5Amp.	1.5mm <sup>2</sup>
10	Aux. Input 1	The grounding is valid according to the function selection switch input.	1.0mm <sup>2</sup>
11	Aux. Input 2		1.0mm <sup>2</sup>
12	Aux. Input 3		1.0mm <sup>2</sup>
13	Aux. Input 4		1.0mm <sup>2</sup>
14	Aux. Input 5		1.0mm <sup>2</sup>
15	Aux. Input 6		1.0mm <sup>2</sup>
16	+5V Output	Connect the power supply of the oil pressure	1.0mm <sup>2</sup>

			sensor with the output voltage signal, with a maximum of 50mA.	
17	Sensor common GND		Connect the battery negative or outer.	1.5mm <sup>2</sup>
18	Oil pressure sensor		Valid when connected to the sensor ground; Oil pressure sensor compatible with voltage and resistance.	1.0mm <sup>2</sup>
19	Engine temperature sensor			1.0mm <sup>2</sup>
20	Raw water temperature sensor			1.0mm <sup>2</sup>
21	Oil level sensor			1.0mm <sup>2</sup>
22	Speed sensor +		Use a shielded wire to connect the speed sensor.	1.0mm <sup>2</sup>
23	Speed sensor -			1.0mm <sup>2</sup>
24	Speed sensor SCR		Connecting speed sensor shielded wire ground.	1.0mm <sup>2</sup>
25	Aux. Output 3	COM	Non-contact normally opened output, Max 5Amp.	1.5mm <sup>2</sup>
26		Normally Open		1.5mm <sup>2</sup>
27	Aux. Output 4	COM	Non-contact normally opened output, Max 5Amp.	1.5mm <sup>2</sup>
28		Normally Open		1.5mm <sup>2</sup>
29	Aux. Output 5	COM	Non-contact normally opened output, Max 5Amp.	1.5mm <sup>2</sup>
30		Normally Open		1.5mm <sup>2</sup>
31	Aux. Output 6	COM	Non-contact normally opened output, Max 5Amp.	1.5mm <sup>2</sup>
32		Normally Open		1.5mm <sup>2</sup>
33	Aux. Output 7	COM	Non-contact normally opened output, Max 5Amp.	1.5mm <sup>2</sup>
34		Normally Open		1.5mm <sup>2</sup>
35	Aux. Output 8	COM	Non-contact normally opened/closed output, Max 5Amp.	1.5mm <sup>2</sup>
36		Normally Open		1.5mm <sup>2</sup>
37		Normally Close		1.5mm <sup>2</sup>
38	CAN_SCR		ECU communication interface : 120Ω shielding wire is recommended, its single-end connect with ground.	1.0mm <sup>2</sup>
39	CAN_H			1.0mm <sup>2</sup>
40	CAN_L			1.0mm <sup>2</sup>
41	RS485 SCR		RS485 communication interface : A 120 Ω shielded wire and good grounding are recommended.	1.0mm <sup>2</sup>
42	RS485 A			1.0mm <sup>2</sup>
43	RS485 B			1.0mm <sup>2</sup>
44	Battery 1 B-		Connected with battery 1	1.0mm <sup>2</sup>
45	Battery 1 B+			1.0mm <sup>2</sup>
46	Battery 2 B-		Connected with battery 2	1.0mm <sup>2</sup>
47	Battery 2 B+			1.0mm <sup>2</sup>

◆ **FC70DR Typical Wiring Diagram**

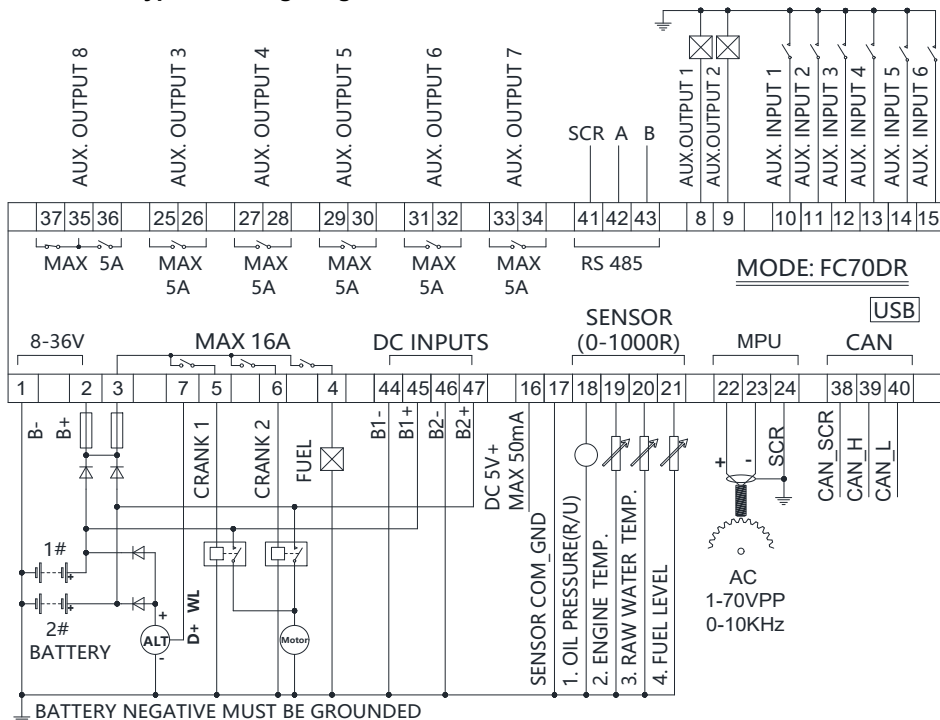

REMARK: 1. The Charger negative needs to be separately connected to the case or the negative terminal of the battery  
 2. To ensure reliable operation of the module and the measuring accuracy, Try not to share the power cord with other device

**Installation instruction**

- ◆ The controller is fixed by four special fixing members and screws, and the screws of the metal fasteners cannot be too tight.
- ◆ Panel Cutout: W186mm\*H142mm.

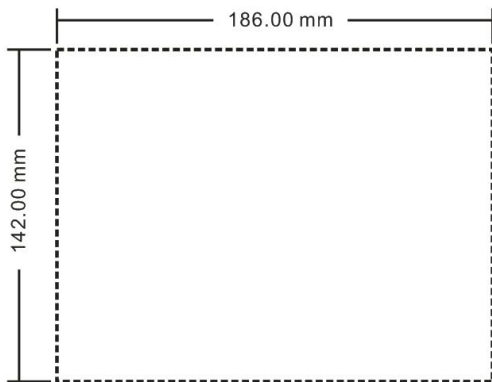

**Note:** If the controller is installed directly in the genset shell or other fluctuated equipment, the rubber pad must be installed.

◆ Battery Voltage Input

FC70DR controller is suitable for 8-36V DC battery voltage. Battery negative must be reliably connected to the enclosure of the engine. The controller power supply B+ and B- must be connected to battery positive and negative, and the wire size must not be less than 2.5mm<sup>2</sup>.

**NOTE:**

In case of floating charger connect charger output to battery positive and negative directly, then, connect battery positive and negative poles to controller positive and negative power supply.

◆ Output and relay expansion

**Note:** All outputs of the controller are relay contacts. The maximum current capacity is described in the "Parameters" in this manual. Please use it in the relay current capacity. If an extended relay is needed, add a continuous current diode (when the extended relay coil is DC) or a resistance-capacitance loop (when the extended relay coil is AC) to both ends of the coil to prevent interference with the controller or other equipment.





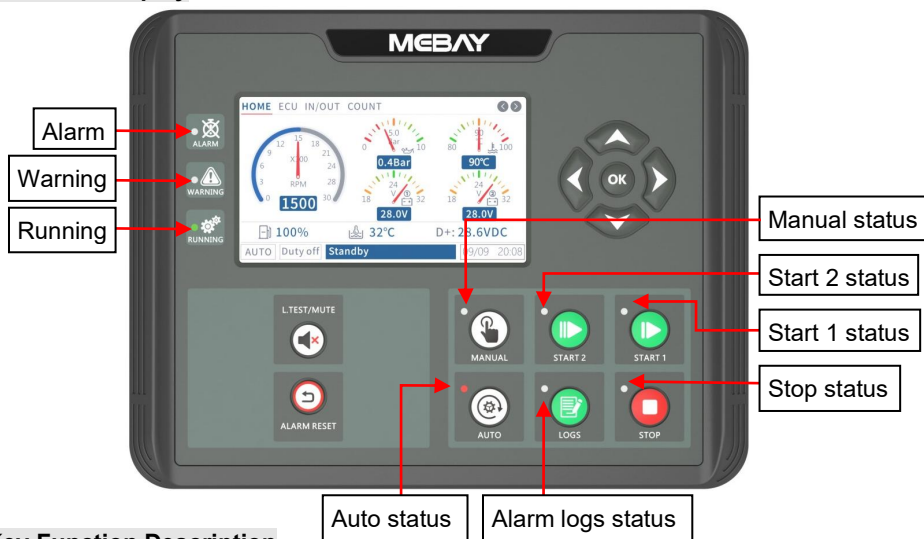





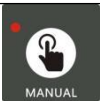

If withstanding voltage test is conducted after the controller has already been installed onto the control panel, please unplug all controller terminal connections in order to prevent high voltage from damaging it.

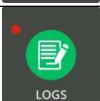

**Panel and display**



**Key Function Description**









KEYS	NAME	Main Function
	Stop Revert	<ul style="list-style-type: none"> <li>◆ Can stop unit under manual/auto mode;</li> <li>◆ Pressing this key can cancel the setting and back to upper class under edition.</li> <li>◆ Under the setting mode with checking data, the data can</li> </ul>

		be saved and system will exit after pressing.
	Start 1	
	Start 2	◆ Start the genset under manual mode.
	Manual	◆ Pressing this key will set the module into manual mode.
	Auto	◆ Pressing this key will set the module into auto mode.
	Alarm record	◆ Pressing this key to check the alarm records under stop mode.
	Alarm reset	◆ In the alarm state, can reset shutdown alarm.
	LED Test/ Warning clear	<ul style="list-style-type: none"> <li>◆ Test if all LED lights are ok, pressing this key to test if all lighted, all off when loosen it.</li> <li>◆ Under warning, pressing this key can clear warning and controller will re-check warning.</li> <li>◆ Under alarm, pressing this key can clear the buzzer call.</li> <li>◆ Pressing this key in 3 seconds can clear the buzzer call, pressing it again in 3 seconds can recover the buzzer call.</li> </ul>
	Left	<ul style="list-style-type: none"> <li>◆ Under display mode, pressing this key to turn left page.</li> <li>◆ Under edition mode, pressing this key to move the digit.</li> </ul>
	Right	<ul style="list-style-type: none"> <li>◆ Under display mode, pressing this key to turn right page.</li> <li>◆ Under edition mode, pressing this key to move the digit.</li> </ul>
	Up	<ul style="list-style-type: none"> <li>◆ Under display mode, parts of the page can move up.</li> <li>◆ Under edition mode, pressing this key to move the digit or increase the numbers.</li> <li>◆ Under records mode, pressing this key to move the digit.</li> </ul>
	Down	<ul style="list-style-type: none"> <li>◆ Under display mode, parts of the page can move down.</li> <li>◆ Under edition mode, pressing this key to move the digit or decrease the numbers.</li> <li>◆ Under records mode, pressing this key to move the digit.</li> </ul>
	OK UI Change	<ul style="list-style-type: none"> <li>◆ Confirm the change under edition mode.</li> <li>◆ Page exited under records checking mode.</li> <li>◆ Black UI and white UI can be switched when Pressing.</li> <li>◆ In standby state, press for 3 seconds to enter the parameter setting mode.</li> </ul>

 	Setting mode	◆ Pressing OK and STOP simultaneously to come into setting mode
--	--------------	---



◆ Alarm records checking

FC70DR controller can save 100 group of alarm records which contains the alarm record data includes detailed data such as alarm time, prompt status information, etc. How to check the alarm records:

1. Enter alarm record page: under stop mode, press  to come into alarm records page;
2. Enter the setting mode, select the alarm record and press  key to enter
3. Press  to turn upper digit and press  to turn lower digit in order to choose the record you need. Press  to confirm the record and come into history records checking page.
4. Press  to turn lower records under records checking page. Press  to turn upper records and press  to revert back to alarm history records page.
5. Exit from records page: In the history records page and checking page, press  to exit.

◆ Manual start

press  and make sure it is in the stop position before starting.

Press "" and the test file indicator is on. At this time, it is detected whether the connection of each sensor is normal. If the sensor is open, the sensor opens an alarm. If it is normal, the unit start process is executed in the following sequence after pressing the "". automatically switch to unit provide the power when the unit is running normally. Press "" The controller performs the parking process at the following timing:

Manual start and stop process:

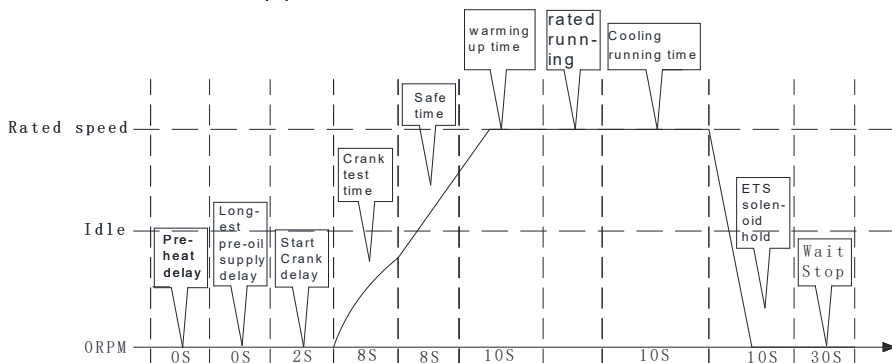

After the manual start is successful, pressing the "automatic key" can be converted into an automatic file. The specific working time is as follows:

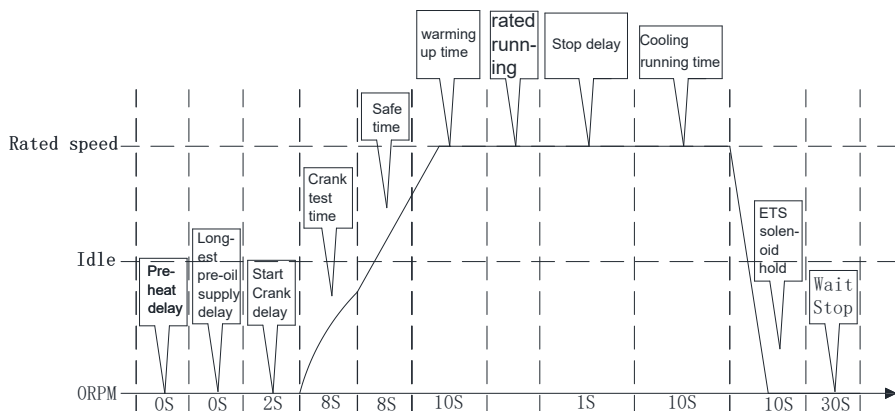

◆ **Automatic starting mode:**

press  and make sure it is in the stop position before starting.

Press "

Auto start and stop process:

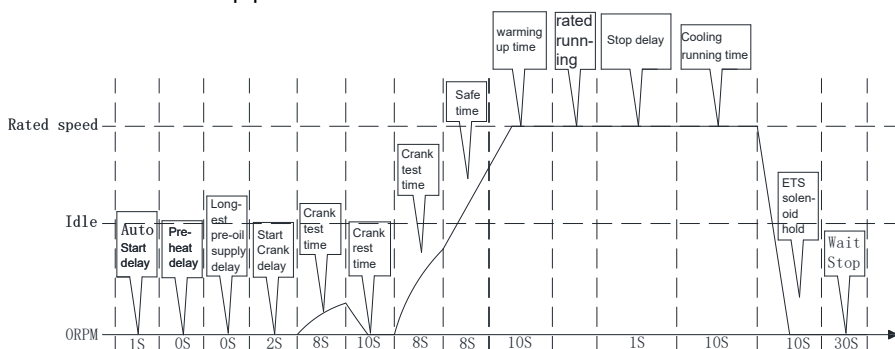

◆ **Notices in Starting Process**

 **Note 1:** During the Cranking time, the controller automatically detects the speed signal, oil pressure value or the charging voltage (according to the parameter setting) to reach the judgment condition of successful start, then the judgment is that the start is successful and the motor relay is closed.





Note 2: Within the safety delay, only respond to emergency stop, immediate stop, over speed, ECU communication Failure, other alarms are not responded to.



Note 3: In the process of shutdown, if the remote starting signal is restored to be valid within the "Cooling time", the rated operation will be entered again.

## Warnings and Shutdown Alarms

### ◆ Warnings



Notes: Warning is a non-serious failure state, which will not harm the system for the time being. It only reminds operators to pay attention to the situation that does not meet the requirements and solve it in time to ensure the continuous operation of the system. When the warning occurs, the units does not stop. Once the fault is removed, the warning is automatically canceled.

### Over Speed Warning

When the controller detects that the engine speed is higher than "**Over speed warning**", Then start warning delay and the duration (Normal warning delay) have not returned to normal, the warning of over speed is reported. "**WARNING**" lights will light up, units will not stop, displays "**Over speed**" on the current fault screen.

### Under Speed Warning

When the controller detects that the engine speed is lower than "**Under speed warning**", Then start warning delay and the duration (Normal warning delay) have not returned to normal, the warning of under speed is reported. "**WARNING**" lights will light up, units will not stop, displays "**Under speed**" on the current fault screen.

### Low Oil Pressure Sensor Warning

When the controller parameter "**Action if low oil pressure**" is set to "**Warning**", and the controller detects that the engine Oil Pressure is lower than "**Low oil pressure warning**", Then start warning delay and the duration (Normal alarm delay) have not returned to normal, the warning of low Oil Pressure is reported. "**WARNING**" lights will light up, units will not stop, displays "**Low OP sensor**" on the current fault screen.

### Low Oil Pressure switch warning

When the controller detects that the AUX. Input "**Low Oil Pressure warning input**" switch is active, it starts warning delay and lasts for Normal alarm delay. When the "**Low Oil Pressure warning input**" switch is enabled, the engine low oil pressure switch warning is reported. "**WARNING**" lights will light up, units will not stop, displays "**Low OP switch**" on the current fault screen.

### High Coolant temperature sensor warning

When the controller parameter "**Action if high water temperature**" is set to "**Warning**", and the controller detects that the coolant temperature value is higher than the "**High coolant temperature warning**", Then start warning delay and the

duration (Normal alarm delay) have not returned to normal, the warning of high coolant temperature warning is reported. **"WARNING"** lights will light up, units will not stop, displays **"High WT sensor"** on the current fault screen.

#### **High Coolant temperature switch warning**

When the controller detects that the AUX. Input **"High Coolant temperature warning input"** switch is active, it starts warning delay and lasts for Normal alarm delay. When the **"High Coolant temperature input"** switch is enabled, the engine high coolant temperature switch warning is reported. **"WARNING"** lights will light up, units will not stop, displays **"High WT switch"** on the current fault screen.

#### **High raw water temperature sensor warning**

When the controller parameter **"Action if high raw water temperature"** is set to **"Warning"**, and the controller detects that the **raw water temperature** value is higher than the **"High raw water temperature warning"**, Then start warning delay and the duration (Normal alarm delay) have not returned to normal, the warning of high raw water temperature warning is reported. **"WARNING"** lights will light up, units will not stop, displays **"High RAW WT sensor"** on the current fault screen.

#### **High raw water temperature switch warning**

When the controller detects that the AUX. Input **"High raw water temperature warning input"** switch is active, it starts warning delay and lasts for Normal alarm delay. When the **"High raw water temperature input"** switch is enabled, the engine high raw water temperature switch warning is reported. **"WARNING"** lights will light up, units will not stop, displays **"High RAW WT switch"** on the current fault screen.

#### **Low fuel level sensor warning**

When the controller detects that the fuel level value is lower than the **"Low fuel level warning"**, Then start warning delay and the duration (Normal alarm delay) have not returned to normal, the warning of Low fuel level warning is reported. **"WARNING"** lights will light up, units will not stop, displays **"Low fuel level-A"** on the current fault screen.

#### **Low fuel level switch warning**

When the controller detects that the AUX. Input **"Low fuel level warning input"** switch is active, it starts warning delay and lasts for Normal alarm delay. When the **"Low fuel level warning input"** switch is enabled, the engine low fuel level switch warning is reported. **"WARNING"** lights will light up, units will not stop, displays **"Low fuel level-D"** on the current fault screen.

#### **External instant warning**

When the controller detects that the AUX. Input **"External instant warning input"** switch is active, it starts warning delay and lasts for Normal alarm delay. When the **"External instant warning input"** switch is enabled, the warning is reported. **"WARNING"** lights will light up, units will not stop, displays **"Instant warn"** on the current fault screen.

#### **Speed signal lost warning**

When the controller parameter **"Action if RPM lost"** is set to **"warning"**, the detected speed value is 0, Then start warning delay and the duration (Normal alarm delay)

have not returned to normal, the warning of speed signal lost warning is reported. **"WARNING"** lights will light up, units will not stop, displays **"Lose speed"** on the current fault screen.

#### **Oil pressure sensor disconnected warning**

When the controller parameter **"Action if low oil pressure sensor disconnected"** is set to **"warning"**, When the oil pressure sensor is detected to be disconnected, Then start warning delay and the duration (Normal alarm delay) have not returned to normal, the warning of Oil pressure sensor disconnected warning is reported. **"WARNING"** lights will light up, units will not stop, displays **"OP sensor open"** on the current fault screen.

#### **Coolant temperature sensor disconnected warning**

When the controller parameter **"Action if water temperature sensor disconnected"** is set to **"warning"**, When the coolant temperature sensor is detected to be disconnected, Then start warning delay and the duration (Normal alarm delay) have not returned to normal, the warning of coolant temperature sensor disconnected warning is reported. **"WARNING"** lights will light up, units will not stop, displays **"WT sensor open"** on the current fault screen.

#### **Raw water temperature sensor disconnected warning**

When the controller parameter **"Action if raw water temperature sensor disconnected "** is set to **"warning"**, When the raw water temperature sensor is detected to be disconnected, Then start warning delay and the duration (Normal alarm delay) have not returned to normal, the warning of raw water temperature sensor disconnected warning is reported. **"WARNING"** lights will light up, units will not stop, displays **"Raw water sensor open"** on the current fault screen.

#### **Fuel Level sensor disconnected warning**

When the controller parameter **"Action if fuel Level sensor disconnected "** is set to **"warning"**, When the fuel Level sensor is detected to be disconnected, Then start warning delay and the duration (Normal alarm delay) have not returned to normal, the warning of fuel Level sensor disconnected warning is reported. **"WARNING"** lights will light up, units will not stop, displays **"FL sensor open"** on the current fault screen.

#### **1<sup>st</sup> Maintenance expiration warning**

When the controller parameter **"Primary maintenance expire"** is set to **"warning"**, when the primary countdown to maintenance is detected as "0" or primary maintenance date less than current date, then start warning delay and the duration (normal alarm delay), the warning of maintenance expiration is reported. **"ALARM"** lights on, without stopping the engine, and displays **"1st maintain end"** on the LCD screen.

#### **2<sup>nd</sup> Maintenance expiration warning**

When the controller parameter **"Secondary maintenance expire"** is set to **"warning"**, when the secondary countdown to maintenance is detected as "0" or second maintenance date less than current date, then start warning delay and the duration (normal alarm delay), the warning of maintenance expiration is reported. **"ALARM"** lights on, without stopping the engine, and displays **"2nd maintain end"** on the LCD screen.

### 3<sup>rd</sup> Maintenance expiration warning

When the controller parameter "**Third maintenance expire**" is set to "**warning**", when the third countdown to maintenance is detected as "0" or third maintenance date less than current date, then start warning delay and the duration (normal alarm delay), the warning of maintenance expiration is reported. "**ALARM**" lights on, without stopping the engine, and displays "**3rd maintain end**" on the LCD screen.

### ECU faults warning

When the controller detects the warning information of ECU, Then start warning delay and the duration (Normal alarm delay) have not returned to normal, the warning of ECU faults warning is reported. "**WARNING**" lights will light up, units will not stop, displays "**ECU faults warn**" on the current fault screen.

### ECU Communication Failure Warning

When the controller parameter "**CAN failure**" is set to "**warning**", and controller does not receive any message sent by ECU. It started to delay and lasted for some time (Normal alarm delay), but still did not receive the message from ECU, the warning of ECU faults warning is reported. "**WARNING**" lights will light up, units will not stop, displays "**ECU comm. fail**" on the current fault screen.

### Low coolant level switch warning

When the controller detects that the AUX. Input "**Low water level warning**" switch is active, it starts warning delay and lasts for Normal alarm delay. When the "**Low water level warning**" switch is enabled, the engine low coolant level switch warning is reported. "**WARNING**" lights will light up, units will not stop, displays "**Low water level**" on the current fault screen.

### Over battery 1 voltage warning

When the controller detects that the battery voltage is over than the "**Over battery 1 voltage warning**", Then start warning delay and the duration (Normal alarm delay) have not returned to normal, the warning of over battery 1 voltage warning is reported. "**WARNING**" lights will light up, units will not stop, displays "**Over BATT 1 volt**" on the current fault screen.

### Under battery 1 voltage warning

When the controller detects that the battery voltage is lower than the "**Under battery 1 voltage warning**", Then start warning delay and the duration (Normal alarm delay) have not returned to normal, the warning of Under battery 1 voltage warning is reported. "**WARNING**" lights will light up, units will not stop, displays "**Under BATT 1 volt**" on the current fault screen.

### Over battery 2 voltage warning

When the controller detects that the battery voltage is over than the "**Over battery 2 voltage warning**", Then start warning delay and the duration (Normal alarm delay) have not returned to normal, the warning of over battery 2 voltage warning is reported. "**WARNING**" lights will light up, units will not stop, displays "**Over BATT 2 volt**" on the current fault screen.

### Under battery 2 voltage warning

When the controller detects that the battery voltage is lower than the **"Under battery 2 voltage warning"**, Then start warning delay and the duration (Normal alarm delay) have not returned to normal, the warning of Under battery 2 voltage warning is reported. **"WARNING"** lights will light up, units will not stop, displays **"Under BATT 2 volt"** on the current fault screen.

### Charging failure warning

When the gap between D+ and B+ is over than this value, and there is charging failure but still high(normal warning delay), then charge failure warns. **"WARNING"** lights will light up, units will not stop, displays **"Charger fault"** on the current fault screen. Once the gap is lower than the value, warns clear.

### ◆ Starting fault

#### Fail to Start

If the number of cranks exceeds the predetermined number of cranks, the failure of start-up will be reported if the start-up of the generating unit is still unsuccessful. **"ALARM"** lights on, without stopping the engine, and displays **"Crank failure "** on the current fault screen.

### ◆ Shutdown Alarms



Warning: After the Shutdown Alarm occurs, the system will be locked

immediately and the unit set will be stopped. Only after troubleshooting, press  key to clear the alarm, can it be re-operated.



Notes: When the shutdown alarm failure occurs, the **"ALARM"** lights will light up and the unit automatically stops.

### Over Speed Alarm

When the controller detects that the engine speed is higher than **"Over speed alarm"**, Then start alarm delay and the duration (Over speed delay) have not lower than **"Over speed revert"**, the alarm of over speed is reported. **"ALARM"** lights will light up, units stops running, and displays **" Over speed "** on the current fault screen.

### Low Oil Pressure Sensor Alarm

When the controller detects that the engine Oil Pressure is lower than **"Low oil pressure alarm"**, Then start alarm delay and the duration (Normal alarm delay) have not returned to normal, the alarm of low Oil Pressure is reported. **"ALARM"** lights will light up, units stops running, and displays **"Low OP sensor"** on the current fault screen.

### Low oil pressure switch alarm

When the controller detects that the AUX. Input port **"Low oil pressure alarm input"**

switch is active. Start low oil pressure switch alarm delay, for a period of time "Normal alarm delay" AUX. Input port "**low oil pressure alarm input**" switch is valid. Then the alarm, the public alarm light "**ALARM**" lights will light up, stop the units operation, and display "**Low OP switch**" on the current fault screen.

### High coolant temperature sensor alarm

When the controller detects that the coolant temperature value is higher than the "**High coolant temperature alarm**", Then start alarm delay and the duration (Normal alarm delay) have not returned to normal, the alarm of high coolant temperature alarm is reported. "**ALARM**" lights will light up, units stops running, and displays "**High WT sensor**" on the current fault screen.

### High coolant temperature switch alarm

When the controller detects that the AUX. Input port "**High coolant temperature alarm switch**" switch is active. Start low oil pressure switch alarm delay, for a period of time "Normal alarm delay" AUX. Input port "**High coolant temperature alarm switch**" is valid. Then the alarm, the public alarm light "**ALARM**" lights will light up, stop the units operation, and display "**High WT switch**" on the current fault screen.

### High raw water temperature sensor alarm

When the controller detects that the oil temperature value is higher than the "**High raw water temperature alarm**", Then start alarm delay and the duration (Normal alarm delay) have not returned to normal, the alarm of high raw water temperature alarm is reported. "**ALARM**" lights will light up, units stops running, and displays "**High RAW WT sensor**" on the current fault screen.

### High raw water temperature switch alarm

When the controller detects that the AUX. Input port "**High raw water temperature alarm switch**" switch is active. Start low oil pressure switch alarm delay, for a period of time "Normal alarm delay" AUX. Input port "**High raw water temperature alarm switch**" is valid. Then the alarm, the public alarm light "**ALARM**" lights will light up, stop the units operation, and display "**High RAW WT switch**" on the current fault screen.

### Low fuel level sensor alarm

When the controller detects that the fuel level value is lower than the "**Low fuel level alarm**", Then start alarm delay and the duration (Normal alarm delay) have not returned to normal, the alarm of low fuel level alarm is reported. "**ALARM**" lights will light up, units stops running, and displays "**Low fuel level sensor**" on the current fault screen.

### Low fuel level switch alarm

When the controller detects that the AUX. Input "**Low fuel level alarm input**" switch is active, it starts alarm delay and lasts for Normal alarm delay. When the "**Low fuel level alarm input**" switch is enabled, the engine low fuel level switch alarm is reported. "**ALARM**" lights will light up, units stops running, and displays "**Low fuel level switch**" on the current fault screen.

### External instant alarm

When the controller detects that the "**External instant alarm input**" switch of the AUX. Input port is valid, the external instant trip is started and the shutdown alarm delay is delayed for a period of time "**Normal alarm delay**" AUX. Input port "**External instant alarm input**" switch When it is valid, it will alarm, the public alarm light "**ALARM**" lights will light up, units stops running, and display "**Instant parking**" on the current fault screen.

### Speed signal lost alarm

When the controller parameter "**Action if RPM lost**" is set to "**alarm**", the detected speed value is 0,Then start alarm delay and the duration (Normal alarm delay) have not returned to normal, the alarm of speed signal lost warning is reported. "**ALARM**" lights will light up, units stops running, displays "**Lose speed**" on the current fault screen.

### Oil pressure sensor disconnected alarm

When the controller parameter "**Action if low oil pressure sensor disconnected**" is set to "**alarm**", When the oil pressure sensor is detected to be disconnected,Then start alarm delay and the duration (Normal alarm delay) have not returned to normal, the alarm of Oil pressure sensor disconnected alarm is reported. "**ALARM**" lights will light up, unit stops running, displays "**OP sensor open**" on the current fault screen.

### Coolant temperature sensor disconnected alarm

When the controller parameter "**Action if water temperature sensor disconnected**" is set to "**alarm**", When the coolant temperature sensor is detected to be disconnected,Then start alarm delay and the duration (Normal alarm delay) have not returned to normal, the alarm of coolant temperature sensor disconnected alarm is reported. "**ALARM**" lights will light up, unit stops running, displays "**WT sensor open**" on the current fault screen.

### Raw water temperature sensor disconnected alarm

When the controller parameter "**Action if raw water temperature sensor disconnected**" is set to "**alarm**", When the raw water temperature sensor is detected to be disconnected,Then start alarm delay and the duration (Normal alarm delay) have not returned to normal, the alarm of raw water temperature sensor disconnected alarm is reported. "**ALARM**" lights will light up, unit stops running, displays "**RAW WT sensor open**" on the current fault screen.

### Fuel Level sensor disconnected alarm

When the controller parameter "**Action if fuel Level sensor disconnected**" is set to "**alarm**", When the fuel Level sensor is detected to be disconnected,Then start alarm delay and the duration (Normal alarm delay) have not returned to normal, the alarm of fuel Level sensor disconnected alarm is reported. "**ALARM**" lights will light up, unit stops running, displays "**FL sensor open**" on the current fault screen.

### 1<sup>st</sup> Maintenance expiration alarm

When the controller parameter "**Primary maintenance expire**" is set to "**alarm**", when the primary countdown to maintenance is detected as "0" or primary maintenance date less than current date, then start alarm delay and the duration

(normal alarm delay), the alarm of maintenance expiration is reported. **"ALARM"** lights on, without stopping the engine, and displays **"1st maintain end"** on the LCD screen.

### 2<sup>nd</sup> Maintenance expiration alarm

When the controller parameter **"Secondary maintenance expire"** is set to **"alarm"**, when the secondary countdown to maintenance is detected as "0" or second maintenance date less than current date, then start alarm delay and the duration (normal alarm delay), the alarm of maintenance expiration is reported. **"ALARM"** lights on, without stopping the engine, and displays **"2nd maintain end"** on the LCD screen.

### 3<sup>rd</sup> Maintenance expiration alarm

When the controller parameter **"Third maintenance expire"** is set to **"alarm"**, when the third countdown to maintenance is detected as "0" or third maintenance date less than current date, then start alarm delay and the duration (normal alarm delay), the alarm of maintenance expiration is reported. **"ALARM"** lights on, without stopping the engine, and displays **"3rd maintain end"** on the LCD screen.

### ECU faults alarm

When the controller detects the alarm information of ECU, Then start alarm delay and the duration (Normal alarm delay) have not returned to normal, the alarm of ECU faults alarm is reported. **"ALARM"** lights will light up, units stops running, displays **"ECU faults warn"** on the current fault screen.

### ECU communication failure alarm

When the controller parameter **"CAN failure"** is set to **"alarm"**, and controller does not receive any message sent by ECU. It started to delay and lasted for some time (Normal alarm delay), but still did not receive the message from ECU, the alarm of ECU faults alarm is reported. **"ALARM"** lights will light up, units stops running, displays **"ECU comm. fail"** on the current fault screen.

### Low coolant level switch alarm

When the controller detects that the AUX. Input **"Low water level alarm"** switch is active, it starts alarm delay and lasts for Normal alarm delay. When the **"Low water level alarm"** switch is enabled, the engine low coolant level switch alarm is reported. **"ALARM"** lights will light up, units stops running, displays **"Low water level"** on the current fault screen.

### Stop failure with speed alarm

When the controller detects that the speed is not "0" after the execution of the shutdown, the alarm of stop failure is reported. **"ALARM"** lights will light up and displays **"Stop fail-RPM"** on the current fault screen.

### Stop failure with pressure alarm

When the controller detects that the Oil **Pressure** is not "0" after the execution of the shutdown, the alarm of stop failure is reported. **"ALARM"** lights will light up and displays **" Stop fail-OP-A "** on the current fault screen.

### Stop failure with D+



When the controller detects that the D+ is not "0" after the execution of the shutdown, the alarm of stop failure is reported. "ALARM" lights will light up and displays "Stop fail-D+" on the current fault screen.

### Parameter setting

#### ◆ Enter the edition page

Please set the parameters according to below steps:

- 1) In the stop mode, Press and hold the button for more than 3 seconds, or the button, press the button, and then release the button to enter the setting menu interface;
- 2) Select the detailed parameter settings of the controller and press the key to enter the password interface;
- 3) The default factory password of the controller is "07623";
- 4) Press and add number 1, press to reduce number 1, press to turn the digit into right, press to turn the digit into left, press once done. Then system comes into menu after confirmation of password setting. The screen will display error if password is wrong. The correct password should be put after pressing any button.
- 5) Press to turn the digit into upper position, press to turn the digit into lower position, press to get into parameters setting page.
- 6) Press to shift up the parameters, press to shift down the parameters, press to get into parameter changing page.
- 7) Press to add number 1, press to reduce number 1, press to turn the digit into right and press to turn the digit into left, press once done. If the parameters setting is in the valid setting range, then it can be saved, if not, it can't be saved.
- 8) Press and to save the parameters and exit from edition page.
- 9) Press to revert back to last class if in any setting position.

Revert back to default: put password "97011" when coming into parameters setting, then all the parameters can be set as defaults.

Note: the data can't be saved if the user didn't press to confirm the setting.

#### ◆ Parameter list.

##### 0) Language settings

No	Parameter	Range(defaults)	Notes
1	Language	0-English 1-简体中文 2-繁体中文	Language option.

##### 1) Delay time setting

No	Parameter	Range (default)	Notes
1	Start delay	0-65000s(1.0s)	The time during the genset starts after

			the remote signal is valid.
2	Return Delay	0-65000s(1.0s)	The time during deactivated to genset stop, after the remote signal is valid.
3	Preheat time	0-6500.0s (0.0s)	The time needed to be preheated before the starter on power.
4	Longest pre-oil supply	0-180.0s(0.0s)	Under pre-oil supply, if the oil pressure is higher than setting value, then pre-oil supply stopped.
5	Fuel output delay	1.0-60.0s (2.0s)	The time the fuel valve relay outputs before the motor operates.
6	Cranking time	3.0-60.0s (8.0s)	The time when the starter is on power.
7	Crank rest time	3.0-60.0s (10.0s)	If crank failure, the waiting time before the second test time.
8	Safety delay	1.0-60.0s (8.0s)	Low oil pressure, high water temperature, under speed, under frequency, under voltage, charge failure are all invalid during this time except for emergency stop and over speed.
9	Warming-up time	0-3600.0s(10.0s)	The time needed for loading.
10	Cooling time	0-3600.0s(30.0s)	After unloading, the time of cooling down by radiator before stop. during the delay, if the remote start signal is valid, then genset will come into rated running.
11	E.T.S. hold time	0-600.0s (10.0s)	Stop solenoid on power time.
12	Fail to stop	5-180.0s (30.0s)	If the RPM is 0 during the stop failure time, then the stop failure time is no needed.
13	Over speed delay	0-10.0s (1.5s)	Over speed alarm delay.
14	Normal alarm delay	2.0-20.0s (5.0s)	The alarm delay except for emergency stop and over frequency
15	Normal warning delay	1.0-20.0s (2.0s)	The warning delay.
16	Pulse speed up delay	0.1-60.0s(0.2s)	The interval time of the pulse speed up relay change.
17	Pulse speed down delay	0.1-60.0s(0.2s)	The interval time of the pulse speed down relay change.

## 2) Engine setting

NO	Parameter	Range(default)	Notes
1	CAN Protocol	<b>0- Disabled</b> 1: J1939 2: Cummins ISB 3: Cummins-CM850 4: Cummins QSX15-CM570 5: Cummins-CM850-PCC13X 6: Cummins-DCEC-QSZ13 7: Cummins-CCEC-QSN 8: Perkins 9: Perkins-1100	CAN protocol Option: the Engine parameters like RPM, oil pressure, water temperature are all from ECU data after choosing the relative protocol.

		10: Volvo 11: Volvo-EMS2 12: Volvo-EMS2b 13: Volvo-EDC4 14: Scania 15: Scania-kw2000 16: Scania-kw2k-coo 17: John Deere 18: mtu-ADEC 19: mtu-ADEC-SAM 20: mtu-ADEC-303 21: mtu-ADEC-304 22: BOSCH 23: GTSC1 24: MTSC1 25: YUCHAI-YCECU 26: Y&C ENGINE-YC6K 27: WEICHAI-WISE15 28: CHANGCHAI-ECU15 29: YUCHAI-LMB 30: MAN 31: J1939-C 32: SDEC-H/D 33: SDEC-E 34: YTO 35: DEUTZ EMR2-2001 36: DEUTZ EMR2-2012 37: DEUTZ EMR3 38: DEUTZ EMR4 39: NEWND ECU13 40: Cummins-CM2150	
2	Flywheel teeth	0-300 <b>(118)</b>	If the setting is 0, (RPM sensor Disabled), then RPM is resulted by Hz.
3	Rated RPM	500-4500RPM <b>(1500)</b>	Choose the meter range and calculate the alarm value.
4	Action if RPM lost	<b>Warning</b> Alarm and stop	This fault can be checked only if there is gens frequency checked as one condition of crank successfully.
5	Over speed alarm	0-200% <b>(114%)</b>	Rated RPM multiplying by this value is regarded as over speed alarm value. When the RPM is higher than the alarm value and comes into over speed delay but still higher (over speed faults delay), then over speed alarms. if the value is set as 200, then the over speed alarm is disabled.
6	Under speed alarm	0-200% <b>(0%)</b>	Rated RPM multiplying by this value is regarded as under speed alarm value. When the RPM is lower than the alarm value and comes into under speed

			delay but still lower (normal faults delay), then under speed alarms. if the value is set as 0, then the under speed alarm is disabled.
7	Over speed warning	0-200% <b>(110%)</b>	Rated RPM multiplying by this value is regarded as over speed warning value. When the RPM is higher than the warning value and comes into over speed delay but still higher, then over speed warns. if the value is set as 200, then the over speed alarm is disabled.
8	Under speed warning	0-200% <b>(90%)</b>	Rated RPM multiplying by this value is regarded as under speed warning value. When the RPM is lower than the warning value and comes into under speed delay but still lower (normal warning delay), then under speed warns. if the value is set as 0, then the over speed alarm is disabled.
9	Battery 1 Rated Voltage	8.0-36.0V <b>(24.0V)</b>	Standard for detecting of over/under voltage of battery.
10	Battery1 over voltage warning	0-200% <b>(135%)</b>	Rated battery voltage multiplying by this value is regarded as over battery voltage warning value. When the battery input is higher than the warning value and comes into over battery voltage delay but still higher (normal faults delay), then over battery voltage warns. if the value is set as 200, then the over battery voltage is disabled.
11	Battery 1 under voltage warning	0-200% <b>(67%)</b>	Rated battery voltage multiplying by this value is regarded as under battery voltage warn value. When the battery input is lower than the warning value and comes into under battery voltage delay but still lower (normal faults delay), then under battery voltage warns. if the value is set as 0, then the under battery voltage is disabled.
12	Battery 2 Rated Voltage	8.0-36.0V <b>(24.0V)</b>	Standard for detecting of over/under voltage of battery.
13	Battery 2 over voltage warning	0-200% <b>(135%)</b>	Rated battery voltage multiplying by this value is regarded as over battery voltage warning value. When the battery input is higher than the warning value and comes into over battery voltage delay but still higher (normal faults delay), then over battery voltage warns. if the value is set as 200, then the over battery voltage is disabled.

14	Battery 2 under voltage warning	0-200%( <b>67%</b> )	Rated battery voltage multiplying by this value is regarded as under battery voltage warn value. When the battery input is lower than the warning value and comes into under battery voltage delay but still lower (normal faults delay), then under battery voltage warns. if the value is set as 0, then the under battery voltage is disabled.
15	Charger warning	1.0-30.0V ( <b>30.0V</b> )	When the gap between D+ and B+ is over than this value, and there is charging failure but still high (normal warning delay), then charge failure warns. Once the gap is lower than the value, warns clear. If the value is set as 300, then the charge failure is disabled.
16	Auto start crank times	1-30 ( <b>3 times</b> )	Crank times under auto mode.
17	E.T.S. hold times	1-10( <b>2 times</b> )	The max E.T.S. hold on power shall be canceled once stop success under auto mode. the output interval time is " Fail to stop ".
18	Crank disconnect	RPM External input Oil pressure <b>RPM/External input</b> RPM/Oil Pressure External input/Oil Pressure RPM/External input/Oil press.	1.If there is no oil pressure sensor, please don't choose the type. 2.Oil pressure switch input is not the crank condition 3.Please check if the running status, stop condition are according with crank condition. 4.Means either of the conditions can be acceptable as crank condition. But all of them should be meet together to regard as stop condition.
19	RPM disconnect	0-200% ( <b>24%</b> )	Rated RPM multiplying by this value is regarded as crank success condition. When the RPM is over the condition value, then system regards it as crank success, motor escaped.
20	Oil pressure disconnect	0-400kpa( <b>200kpa</b> )	When the engine oil pressure is over the condition value, then system regards it as crank success, motor escaped.
21	Oil pressure delay	0-20.0s ( <b>0.0s</b> )	When the crank condition contains oil pressure, if the oil pressure is higher than the presets value and continue for few seconds, then it is regarded as crank success.
22	OP pre-supply stop	50-600kpa( <b>200kpa</b> )	When the oil pressure is over the condition value, then pre-oil supply is

			stopped.
23	Battery charging start	8.0-30.0( <b>25.6V</b> )	When the battery voltage is lower than start value and remains 10s under non-running status, then the relay is opened. When it is higher than the close value and remains 10s, relay is closed. Once coming into running mode, there is no output.
24	Battery charging stop	10.0-36.0( <b>27.8V</b> )	

### 3) Input setting

NO	Parameter	Range (defaults)	Notes
1	Pressure/Temperature unit	°C/KPA °C/ <b>BAR</b> °C/PSI °F/KPA °F/ <b>BAR</b> °F/PSI	Unit display.
2	Coolant temperature sensor	0. Disable 1. From ECU 2. User-define resistance curve 3. <b>VDO 40-120 °C</b> 4. MEBAY-001B 5. SGH 6. SGD 7. SGX 8. CURTIS 9. DATCON 10. VOLVO-EC 11. 3015238 12. PT100 13. MEBAY-Mier 14. WEICHAH 40-120°C 15. GENCON 40-120°C	Choose the usual water temperature sensor, If the sensor used by the user is not the commonly used type, it can be User-defined.
3	Action if coolant temperature sensor disconnected	Disable <b>Warning</b> Alarm and stop	Action if Water temperature sensor disconnected.
4	High coolant temperature alarm	20-200°C ( <b>200 °C</b> )	When the water temperature is higher than the alarm value and comes into high temperature delay but still higher (normal faults delay), then high temperature alarms. if the value is set as 200, then the high temperature alarm is disabled.
5	High coolant temperature warning	20-200°C ( <b>98 °C</b> )	When the water temperature is higher than the value and comes into high temperature warning delay but still higher (normal warning delay), then high temperature warns. If it is lower

			than the value then warning clears. If the value is set as 200, then the high temperature warning is disabled.
6	Low coolant temperature alarm	20-200°C <b>(20 °C)</b>	When the water temperature is lower than the alarm value and comes into low temperature delay but still lower (normal faults delay), then low temperature alarms. if the value is set as 200, then the low temperature alarm is disabled.
7	Low coolant temperature warning	20-200°C <b>(60 °C)</b>	When the water temperature is lower than the value and comes into low temperature warning delay but still lower(normal warning delay), then low temperature warns. If it is higher than the value then warning clears. If the value is set as 200, then the low temperature warning is disabled.
8	Raw water temperature sensor	0. Disable 1. From ECU 2. User-define resistance curve 3. <b>VDO 40-120 °C</b> 4. MEBAY-001B 5. SGH 6. SGD 7. SGX 8. CURTIS 9. DATCON 10. VOLVO-EC 11. 3015238 12. PT100 13. MEBAY-Mier 14. WEICHAH 40-120°C 15. GENCON 40-120°C	Choose the usual water temperature sensor, If the sensor used by the user is not the commonly used type, it can be User-defined.
9	Action if raw water temperature sensor disconnected	Disable <b>Warning</b> Alarm and stop	Action if Water temperature sensor disconnected.
10	High raw water temperature alarm	0-200°C <b>(200 °C)</b>	When the raw water temperature is higher than the alarm value and comes into high raw water temperature delay but still higher (normal faults delay), then high raw water temperature alarms. if the value is set as 200, then the high raw water temperature alarm is disabled.
11	High raw water temperature warning	0-200°C <b>(60 °C)</b>	When the raw water temperature is higher than the value and comes into high raw water temperature warning delay but still higher r(normal warning

			delay), then high raw water temperature warns. If it is lower than the value then warning clears. If the value is set as 200, then the high raw water temperature warning is disabled.
12	Low raw water temperature alarm	0-200°C <b>(0 °C)</b>	When the raw water temperature is lower than the alarm value and comes into low raw water temperature delay but still lower (normal faults delay), then low raw water temperature alarms. if the value is set as 200, then the low raw water temperature alarm is disabled.
13	Low raw water temperature warning	0-200°C <b>(20 °C)</b>	When the raw water temperature is lower than the value and comes into low raw water temperature warning delay but still lower(normal warning delay), then low raw water temperature warns. If it is higher than the value then warning clears. If the value is set as 200, then the low raw water temperature warning is disabled.
14	Oil pressure sensor	0:Disable 1:From ECU 2:User defined-Resistance 3:User defined-Voltage 4:Volt In 1MPa-0-5V 5:Volt In 1MPa-0.5-4.5V <b>6: VDO 0-10Bar</b> 7:MEBAY-003B 8:SGH 9:SGD 10:SGX 11:CURTIS 12:DATCON 10Bar 13:VOLVO-EC 14:3015237 15:WEICHA1 0-0.6MPa 16:GENCON 0-10Bar	Choose the usual oil pressure sensor, If the sensor used by the user is not the commonly used type, it can be User-defined.
15	Action if oil pressure sensor disconnected	Disable <b>Warning</b> Alarm and stop	Action if oil pressure sensor disconnected.
16	Low oil pressure alarm	0-999kpa( <b>0kpa</b> )	When the oil pressure is lower than the alarm value and comes into low oil pressure delay but still lower (normal faults delay), then low oil pressure alarms. if the value is set as 0, then the low oil pressure alarm is disabled.
17	Low oil pressure	0-999kpa( <b>103kpa</b> )	When the oil pressure is lower than the warning value and comes into low oil



	warning		pressure delay but still lower (normal faults delay), then low oil pressure warning. if the value is set as 0, then the low oil pressure warning is disabled.
18	Fuel level sensor	0. <b>Disable</b> 1. User-define resistance curve 2. 0-100Ω 3. 100-0Ω 4. 0-107Ω 5. 107-0Ω 6. 0-180Ω 7. 180-0Ω 8. 180-10Ω 9. 10-180Ω 10. 120-10Ω 11. 10-120Ω 12. 90-0Ω 13. 0-90Ω 14. 0-30Ω 15. 73-10Ω 16. 240-33Ω 17. 33-100Ω 18. 0-200Ω 19. 200-0Ω 20. 100-33Ω	If the sensor used by the user is not the commonly used type, it can be User-defined.
19	Action if fuel Level sensor disconnected	Disable <b>Warning</b> Alarm and stop	Action if Fuel level sensor disconnected.
20	Low fuel level warning	0-100%( <b>20%</b> )	When the fuel level is lower than the value and comes into low fuel level warning delay but still lower (normal warning delay), then low fuel level warns. If it is higher than the value then warning clears. If the value is set as 0, then the low fuel level warning is disabled.
21	Low fuel level alarm	0-100%( <b>0%</b> )	When the fuel level is lower than the alarm value and comes into low fuel level delay but still lower (normal faults delay), then low fuel level alarms. if the value is set as 0, then the low fuel level alarm is disabled.
22	AUX. INPUT 1 (Pin10)	0-40 ( <b>20. Remote start</b> )	
23	AUX. INPUT 1 valid	<b>0-Normal close</b> 1-Normal open	
24	AUX. INPUT 2 (Pin11)	0-40 ( <b>2. Low oil pressure warning</b> )	
25	AUX. INPUT 2 valid	<b>0-Normal close</b> 1-Normal open	
26	AUX. INPUT 3 (Pin12)	0-40 ( <b>4. High water temperature warning</b> )	
27	AUX. INPUT 3 valid	<b>0-Normal close</b> 1-Normal open	
			Set the default value (please refer to the AUX. input function table)

28	AUX. INPUT 4 (Pin13)	0-40 ( <b>9. High raw water temperature alarm</b> )	Set the state when the AUX. input is valid.
29	AUX. INPUT 4 valid	<b>0-Normal close</b> 1-Normal open	
30	AUX. INPUT 5 (Pin14)	0-40 ( <b>16. External instant alarm</b> )	
31	AUX. INPUT 5 valid	<b>0-Normal close</b> 1-Normal open	
32	AUX. INPUT 6 (Pin15)	0-40 ( <b>0. Disable</b> )	
33	AUX. INPUT 6 valid	<b>0-Normal close</b> 1-Normal open	

#### AUX. input function table

#### 0.Disable.

- 1.Low oil pressure alarm.
- 2.Low oil pressure warning.
- 3.High water temperature alarm.
- 4.High water temperature warning.
- 5.Low water level warning.
- 6.Low water level alarm.
- 7.Low fuel level warning.
- 8.Low fuel level alarm.
- 9.High raw water temperature alarm .
- 10.High raw water temperature warning.
- 11.Low raw water temperature alarm .
- 12.Low raw water temperature warning.
- 13.Raw water circuit blockage alarm.
- 14.Raw water circuit blockage warning.
- 15.External instant warning.
- 16.External instant alarm.
- 17.Louver status.
- 18.Soundproof alarm: audio alarm output is disabled if there is signal output.
- 19.Reset Alarm: Can reset shutdown alarm and trip alarm when input is active.
- 20.Remote start : the unit comes into start procession if this signal is valid and under auto mode.
- 21.Start successful: When the start successful condition includes "external input", you need to select this item. When it is valid, it means the start is successful.
- 22.Simulate STOP;
- 23.Simulate MANUAL;
- 24.Simulate AUTO;
- 25.Simulate START1;
- 26.Simulate START2;
- 27.Simulate left.
- 28.Simulate right.
- 29.-40 Reserved.

#### 4) Output setting

No	Parameter	Range(defaults)	Notes
1	Fixed output	<b>Fuel</b>	Set the default value (please refer to the AUX. Output function table)
2		<b>Crank 1</b>	
3		<b>Crank 2</b>	
4	AUX.OUTPUT 1 (Pin8)	0-50( <b>0. Disable</b> )	Set the state when the AUX. output is valid.
5	AUX.OUTPUT 2 (Pin9)	0-50( <b>0. Disable</b> )	
6	AUX.OUTPUT 3	0-50( <b>27. Over speed alarm</b> )	

	(Pin25\26)	
7	AUX.OUTPUT 4 (Pin27\28)	0-50( <b>10. Rated running</b> )
8	AUX.OUTPUT 5 (Pin29\30)	0-50( <b>29. High temp warning</b> )
9	AUX.OUTPUT 6 (Pin31\32)	0-50( <b>31. Low temp warning</b> )
10	AUX.OUTPUT 7 (Pin33\34)	0-50( <b>33. Low oil pres warning</b> )
11	AUX.OUTPUT 8 (Pin35\36\37)	0-50( <b>36. High RW temp alarm</b> )

**AUX. Output function table**
**0.Disable.**

- 1.**Public abnormal:** Output when there are any warnings and any alarms in the unit.
- 2.**Public warning:** when there is any warning output.
- 3.**Public alarm:** when there is any alarm output, alarm locks till revert back.
- 4.**Audio alarm:** when there is any alarm output, the Audio controls.
- 5.**Louver control:** Output when power on running, stop after stopping.
- 6.**Pre-oil supply control:** Under pre-oil supply,if the oil pressure is higher than setting value or pre-oil supply time ends, then pre-oil supply stopped.
- 7.**Crank 1 output:** output once cranking, no output in other mode.
- 8.**Crank 2 output:** output once cranking, no output in other mode.
- 9.**Unit running:** output under running, off once RPM is lower than cranking RPM. The crank success condition can be set.
- 10.**Rated running:** there is output under rated running.
- 11.**E.S.T. hold:** shutdown output, it is used for unit with stop solenoid. when the setting value of shutdown delay is over, then it is off.
- 12.**System in stop:** there is output under stop mode.
- 13.**System in manual:** there is output under manual mode.
- 14.**System in auto:** there is output under auto mode.
- 15.**Reserved:**
- 16.**Battery charging control:** there is output if the voltage is lower than the preset value under standby status and shutdown after start and in running status.
- 17.**High battery 1 volt:** Action when the battery 1 voltage is too high warning.
- 18.**Low battery 1 volt:** Action when the battery 1 voltage is too low warning.
- 19.**High battery 2 volt:** Action when the battery 2 voltage is too high warning.
- 20.**Low battery 2 volt:** Action when the battery 2 voltage is too low warning.
- 21.**Charging failure:** Action when charging failure warning.
- 22.**Start failure:** Action when starting failure alarm.
- 23.**STOP failure:** Action when shutdown failure alarm.
- 24.**Under speed warning:** Action when under speed warning.
- 25.**Under speed alarm:** Action when under speed alarm.
- 26.**Over speed warning:** Action when speeding warning.
- 27.**Over speed alarm:** Action when over speed alarm.
- 28.**High temp alarm:** Action when high temperature alarm.
- 29.**High temp warning:** Action when high temperature warning.
- 30.**Low temp alarm:** Action when low temperature alarm.
- 31.**Low temp warning:** Action when low temperature warning.
- 32.**Low oil pres alarm:** Action when low oil pressure alarm.
- 33.**Low oil pres warning:** Action when low oil pressure warning.

- 34.Low fuel level alarm:** Action when low fuel level alarm.  
**35.Low fuel level warn:** Action when low fuel level warning.  
**36.High RW temp alarm:** Action when high raw water temperature alarm.  
**37.High RW temp warning:** Action when high temperature warning.  
**38.Low RW temp alarm:** Action when low raw water temperature alarm.  
**39.Low RW temp warning:** Action when low raw water temperature warning.  
**40.ECU power:** apply to electrical ECU engine, used for control ECU power.  
**41.ECU stop:** apply to electrical ECU engine, used for control ECU shutdown.  
**42.ECU warning:** there is a warn signal from ECU.  
**43.ECU alarm:** there is an alarm signal from ECU.  
**44.ECU communication failure:** Cannot communicate with ECU.  
**45.Pulse speed up output:** the pulse shall be sent out in the interval of "Pulse speed up delay" under speed - up.  
**46.Pulse speed down output:** the pulse shall be sent out in the interval of "Pulse speed down delay" under stop idle speed.  
**47.-50 Reserved.**

### 5) CAN communication

No	Parameter	Range( <i>default</i> )	Notes
1	CAN failure	Disable Warn <b>Alarm and Stop</b>	ECU communication failure.
2	ECU warning	Disable/ <b>Enable</b>	ECU warnings enable.
3	ECU alarm action	Disable <b>Warning</b> Alarm and stop	Action if ECU alarms.
4	Mask SPN	0-12	Up to 12 sets of alarm codes can be input, and the controller will not respond to the input alarm codes.
5	ECU page	Disable/ <b>Enable</b>	Set whether the ECU page is displayed.

### 6) Module settings

No	Parameter	Range(defaults)	Notes
1	User password	00000-65535 <b>(07623)</b>	Change the password.
2	Controller ID	1-255( <b>16</b> )	The IP built by controller and PC.
3	RS485 baud rate	0-4800 1-9600 <b>2-19200</b> 3-38400 4-57600 5-115200	RS485 communication baud rate.
4	Primary Modes	<b>STOP</b> Manual Auto Auto save	The primary modes on power, easy for user operation. Note: auto record function can't record the mode with load.
5	Start screen display time	0-20.0s ( <b>5.0s</b> )	Start screen display time,0: No-display.
6	Back lightness	20-100% ( <b>80%</b> )	Back lightness adjustment.
7	Saving mode	5.0-6000.0s <b>(600.0s)</b>	LCD light will be closed automatically without any button pressed after delay. If setting as 6000.0s,

			back light always lighted.
8	Homing display	5.0-600.0s <b>(600.0s)</b>	The time when the page reverts back to the home page. If setting as 600.0s: disabled.
9	LOGO delay display under standby	5.0-6000.0 <b>(6000.0s)</b>	Start screen will be opened without any button pressed after delay. If setting as 6000.0s: disabled.
10	Display UI selection	<b>Dark mode</b> Bright mode	Set the default display mode of the display interface after the controller is powered on.

### 7) Working and maintenance setting

No	Parameter	Range(defaults)	Notes
1	Working plan format	<b>Disable</b> Every month Every week	This mode must be under auto mode. Working plan is disabled once setting as disable. The working plan will be executed according the chosen date when setting as every month. The working plan will be executed according the chosen date when setting as every week.
2	Maintenance date per month	From 1 <sup>st</sup> to 31 <sup>st</sup> <b>Default: the first day</b>	The date chosen for every month.
3	Maintenance date per week	Monday to Sunday <b>Default: Sunday</b>	The date chosen for every week.
4	Maintenance start time	00:00-23:59 <b>(00:00)</b>	Maintenance start time setting.
5	Maintenance running time	1-120m( <b>5min</b> )	Maintenance running time setting.

### 8) Working plan

No	Parameter	Range(defaults)	Notes
1	Working plan	<b>Disable</b> Enable 1: remote start Enable 2: running always	Working plan start condition.
2	Start time	00:00-23:59 ( <b>08:00</b> )	The start time allowed.
3	End time	00:00-23:59 ( <b>17:00</b> )	The end time allowed (the next day is valid).
4	Dates	1-31	Multiple choices according to the reality. The longest running time is 24 hours.

### 9) Maintenance plan

No	Parameter	Range(defaults)	Notes
1	Primary Maintenance countdown	0-5000h( <b>5000h</b> )	When it is set as 5000, then this function is disabled.
2	Secondary maintenance countdown	0-5000h( <b>5000h</b> )	
3	Third maintenance countdown	0-5000h( <b>5000h</b> )	
4	Primary maintenance date	<b>2000/01/01</b> -2099/12/31	When it is set as 2000/01/01, this function is disabled.
5	Secondary maintenance date	<b>2000/01/01</b> -2099/12/31	
6	Third maintenance date	<b>2000/01/01</b> -2099/12/31	
7	Primary maintenance	<b>Warning</b>	The action after the primary

	expire	Alarm and stop	maintenance expired.
8	Secondary maintenance expire	<b>Warning</b> Alarm and stop	
9	Third maintenance expire	<b>Warning</b> Alarm and stop	

### 10) Data/time setting

No	Parameter	Range(defaults)	Notes
1	Date/Time	2000/01/01-2099/12/31	Internal calendar, please calibrate regularly.
2	Current time	00:00:00-23:59:59	

### 11) Self-define curve

No	Parameter	Range(defaults)
1	User-define oil pressure resistance curve	<b>Sensor curve can be User-defined by panel buttons, resistance and according value should be input, MAX 15 groups, MIN 2 groups.</b>  <b>Rule: resistance should be input from small to large.</b>
2	User-define oil pressure voltage curve	
3	User-define coolant temperature curve	
4	User-define raw water temperature curve	
5	User-define fuel level curve	

### Fault finding

Symptoms	Possible Solutions
Controller no response with power	Check DC voltage. Check DC fuse. Check if the terminal 1 and 2 is with battery voltage.
Units shutdown	Check the water/cylinder temperature is too high or not. Check DC fuse.
Low oil pressure alarm	Check oil pressure sensor and its wiring. Check the oil pressure sensor type and controller settings must be consistent. Check whether the low oil pressure sensor is normal.
High temperature alarm	Check temperature sensor and its wiring. Check the temperature sensor type and controller settings must be consistent. Check whether the temperature sensor is normal.
Shutdown Alarm in running	Check related switch and its connections according to the information on LCD. Check programmable inputs.
Fail to start	Check the engine fuel circuit and its connecting wires; Check whether the starting battery voltage is normal; Check the speed sensor and its connecting wire;
Starter motor does not respond	Check the wiring to the starter. Check start battery.
USB communication is abnormal	Check the USB connection. Check whether the USB port of the computer is normal. Check whether the USB driver is installed.
RS485 cannot communicate normally	Check the connection. Check if the communication ID number setting is correct. Check if the A and B lines of RS485 are reversed. Check if the RS485 communication line driver is installed or not.

	<p>Check if the communication port of the PC is damaged.          Add a 120 Ω resistor between the AB of the controller RS485.</p>
<p>ECU warning or stop</p>	<p>Get information from LCD of alarm page;          If there is detailed alarm, check engine according to description.          If not, please refer to engine manual according to SPN alarm code.</p>